

PLEASE CHECK WWW.MOLEX.COM FOR LATEST PART INFORMATION

Part Number: [5013951000](#)
Status: **Active**
Description: 3.30mm Pitch Crimp Terminal, Female, 18-20 AWG, Reel

Documents:

[Drawing \(PDF\)](#) [RoHS Certificate of Compliance \(PDF\)](#)

General

Product Family	Crimp Terminals
Series	501395
Application	Signal
Crimp Quality Equipment	Yes
Product Name	N/A
UPC	822348810550

Physical

Gender	Female
Material - Metal	Copper Alloy
Material - Plating Mating	Tin
Material - Plating Termination	Tin
Net Weight	169.000/mg
Packaging Type	Reel
Termination Interface: Style	Crimp or Compression
Wire Insulation Diameter	1.75-2.60mm
Wire Size AWG	18, 20
Wire Size mm ²	N/A

Material Info

Reference - Drawing Numbers

Sales Drawing	SD-501395-001
---------------	---------------

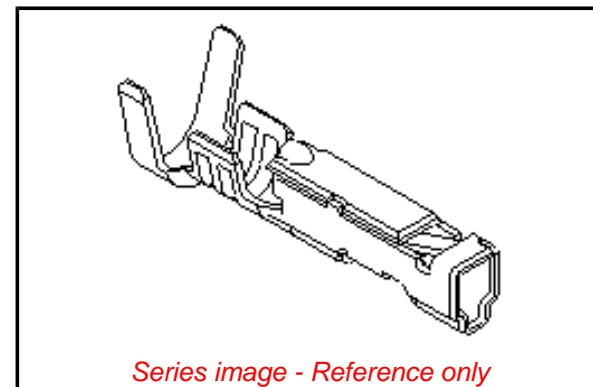

EU ELV

Not Relevant

EU RoHS

Compliant

REACH SVHC

Not Contained Per -
ED/21/2016 (20 June
2016)

Halogen-Free

Status

Low-Halogen

**Need more information on product
environmental compliance?**

Email productcompliance@molex.com
Please visit the [Contact Us](#) section for any
non-product compliance questions.

China ROHS
ELV

Green Image
Not Relevant

Search Parts in this Series

[501395](#) Series

Mates With

[501329](#) Crimp Housing . [56265](#) Crimp
Terminal

Use With

[501328](#) Inertia Lock Crimp Housing . [51284](#)
Crimp Housing . [51347](#) Crimp Housing

Mouser Electronics

Authorized Distributor

Click to View Pricing, Inventory, Delivery & Lifecycle Information:

[Molex:](#)

[501395-1000](#) [501395-1000 \(Cut Strip\)](#) [501395-1000 \(Mouser Reel\)](#)