

4

3

2

1

THIS DRAWING IS UNPUBLISHED.

RELEASED FOR PUBLICATION

© COPYRIGHT

ALL RIGHTS RESERVED.

LOC DIST

REVISIONS

P	LTR	DESCRIPTION	DATE	DWN	APVD

REPLACED BY OCEAN STYLE APPLICATOR PART NUMBER

FOR REPLACEMENT PARTS FOR APPLICATOR REFER TO ADDITIONAL PAGE(S). SPARE PARTS KIT (IF LISTED) WILL REMAIN AVAILABLE.

THE REPLACEMENT OCEAN STYLE APPLICATOR HAS THE SAME TERMINATOR/PRESS INTERFACE AS APPLICATOR

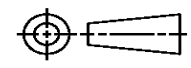
THIS DRAWING IS A CONTROLLED DOCUMENT.		DWN	 TE Connectivity		
DIMENSIONS:		CHK			
TOLERANCES UNLESS OTHERWISE SPECIFIED:		APVD	NAME		
 <ul style="list-style-type: none"> 0 PLC ± 1 PLC ± 2 PLC ± 3 PLC ± 4 PLC ± ANGLES ± 		PRODUCT SPEC	RESTRICTED TO		
		APPLICATION SPEC	SIZE	CAGE CODE	DRAWING NO
MATERIAL	FINISH	WEIGHT	A3	C-	
		SCALE	SHEET	OF	REV

PART NUMBER	REV	FIRST USED	POWER UNIT	FEED TYPE	DESCRIPTION
1852216-1	A	122500-1	LEADMAKER	POST FEED	CUTS CARRIER
1852216-2	A	565435-5	BENCH MODEL K	PRE FEED	CUTS CARRIER
1852216-3	A	354500-1	BENCH MODEL G	PRE FEED	CUTS CARRIER
1852216-6	A	122500-1	LEADMAKER	POST FEED	CONTINUOUS CARRIER
7-1852216-7	A	-	-	-	SPARE PARTS

- △ RECOMMENDED SPARE PARTS
- △ GREASE LIGHTLY
- △ GUARD MUST BE IN PLACE WHEN OPERATING APPLICATOR IN A BENCH MACHINE
- △ GRIND AT ASSY.

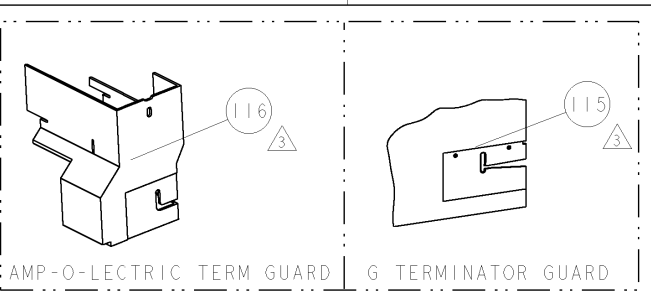

TERMINAL NAME: D-2 RECEPTACLE CONTACT			
SOCKET	-	AMP TERMINAL - AMP CRIMP SPECS	
1318105	-		
		PAD LTR	CRIMP HEIGHT
		A	1.19mm ± 0.05mm [0.47 ± .002]
		B	1.05mm ± 0.05mm [0.41 ± .002]
		C	.94mm ± 0.05mm [0.37 ± .002]
		D	-
		CRIMP	SIZE
		WIRE	1.57mm [0.062]
		INSUL	1.90mm [0.075]
WIRE STRIP LENGTH	3.6-4.6	TERM APPL SPEC	114-5258
		FEED	8.08
		APPL INSTRUCTIONS	408-8040
		SET UP GAUGE	458637-1

REV	DATE	BY	CHKD	DESCRIPTION
A	MARCH2006	CMR	TE	PRODUCT RELEASE
A1	27MAR2007	BH	BH	ECR-07-007086

REV	DATE	BY	CHKD	DESCRIPTION	ITEM NO		
-	2	2	2	2	4-354779-4	PIN, WIRE DISC, .3210	128
-	2	2	2	2	3-354779-6	PIN, WIRE DISC, .3170	127
-	2	2	2	2	2-354779-1	PIN, WIRE DISC, .3095	126
-	-	REF	-	-	455749-1	GUARD WINDOW	116
-	-	REF	-	-	679532-1	INSERT, GUARD	115
-	1	1	1	1	690603-1	SPRING ASSIST AMP-O-MATOR APPLICATOR	112
-	1	1	1	1	1424350-1	HOLDER, PIN, WIRED	92
-	1	1	1	1	1-21002-7	SCR, BTN SKT HD CAP 6-32 X .375	91
-	1	1	1	1	318563-1	GUARD, FRONT CHIP	89
-	1	1	1	1	455888-5	SPACER, CRIMPER	82
-	1	1	1	1	1490524-1	DEPRESSOR, SPACER	76
-	1	1	1	1	1490525-3	DEPRESSOR, WIRE	75
-	1	1	1	1	4088040	SF APPL INST 408-8040	72
-	1	1	1	1	217238-1	GENERAL INSTRUCTION PKG	71
-	3	3	3	3	23147-7	SPRING, COMPRESSION	70
-	1	1	1	1	461264-1	PLATE, IDENTIFICATION	67
-	2	2	2	2	21017-2	SCREW, DRIVE	66
-	1	1	1	1	986950-1	WASHER, FLAT PRECISION	64
-	1	1	1	1	21009-2	SCR, SET, SELF LOCKING 1/4-20 X .250	63
-	1	1	1	1	23030-1	SCR, SKT HD CAP 6-32 X .25	62
-	1	1	1	1	22733-8	SCR, BHSC, SELF-LOCKING, 8-32 X .375	60
-	1	1	1	1	2-22603-0	SCR, HEX HD CAP 8-32 X .312	59
-	1	1	1	1	458537-2	PAWL, FEED	56
-	4	4	4	4	2-21002-2	SCR, BTN SKT HD CAP 8-32 X .500	54
-	2	2	2	2	2-21000-9	SCR, SKT HD CAP 8-32 X .750	53
-	1	1	1	1	21018-5	NUT, HEX, REG 6-32	52
-	1	1	1	1	811242-2	BUMPER, HOLD DOWN	51
-	1	1	1	1	690753-1	SPACER, TONKER	50
-	-	1	-	-	690602-6	CAM, PRE FEED, 1 5/8	49
-	-	1	-	-	690602-5	CAM, PRE FEED, 1 1/8	48
-	1	1	1	1	690501-4	CAM, POST FEED, 1 5/8	47
-	1	1	1	1	459456-1	APPL. BASIC SUB ASSY (SIDE WISE MQCA)	46
-	1	1	1	1	690191-1	PLUG, NYLON	45
-	1	1	1	1	455673-1	RAM, SIDE FEED	44
-	1	1	1	1	690125-1	SHIM SUB-ASSY	43
-	1	1	1	1	690124-1	WASHER, RAM (.115)	42
-	1	1	1	1	7-21002-9	SCR, BTN SKT HD CAP 5/16-24 X 1.00	41
-	1	1	1	1	23241-6	BALL, STEEL	40
-	1	1	1	1	690170-1	SPRING, COMPRESSION	39
-	1	1	1	1	690142-4	DISC, INSULATION	38
-	1	1	1	1	354777-1	WIRE DISC, ASSEMBLY	37
-	1	1	1	1	22480-5	SPRING, COMPRESSION	36
-	1	1	1	1	690212-1	POST, RAM	35
-	1	1	1	1	690786-3	TERMINAL SUPPORT	34
-	2	2	2	2	2-21002-4	SCR, BTN SKT HD CAP 8-32 X .750	33
-	1	1	1	1	21024-5	WASHER, SPRG LOCK, REG NO 10	32
-	1	1	1	1	3-21000-4	SCR, SKT HD CAP 10-32 X .375	31
-	1	1	1	1	1-1320908-5	SPACER, STRIP GUIDE	30
-	1	1	1	1	1633091-1	ASSEMBLY, STRIP GUIDE	29
-	1	1	1	1	1-455888-0	SPACER, CRIMPER	28
-	1	1	1	1	1320928-3	PLATE, STRIP GUIDE	24
-	1	1	1	1	690472-2	STRIPPER	22
-	1	1	1	1	2-21000-7	SCR, SKT HD CAP 8-32 X .500	21
-	4	4	4	4	21024-4	WASHER, SPRG LOCK, REG NO 8	20
-	1	1	1	1	691353-1	STRIPPER	19
-	1	1	1	1	679625-1	SHEAR HOLDER, FRONT (NO CUT)	17
-	1	1	1	1	3-22280-3	SPRING, COMPRESSION	12
-	1	1	1	1	690461-1	STOP, SHEAR	11
-	1	1	1	1	690459-1	SHEAR HOLDER, FRONT	10
-	1	1	1	1	462006-1	FLOATING SHEAR, FRONT	9
1	1	1	1	1	1-1633107-8	ANVIL, COMBINATION .062	8
-	1	1	1	1	1-240641-8	SPACER	7
-	1	1	1	1	2-455889-0	DEPRESSOR, SHEAR	5
-	1	1	1	1	2-238011-0	BLOCK, CRIMPER SPACER	4
1	1	1	1	1	3-1213077-9	CRIMPER, INSULATION PREMIUM	3
-	1	1	1	1	455888-1	SPACER, CRIMPER	2
1	1	1	1	1	1-456403-6	CRIMPER, WIRE PREMIUM	1

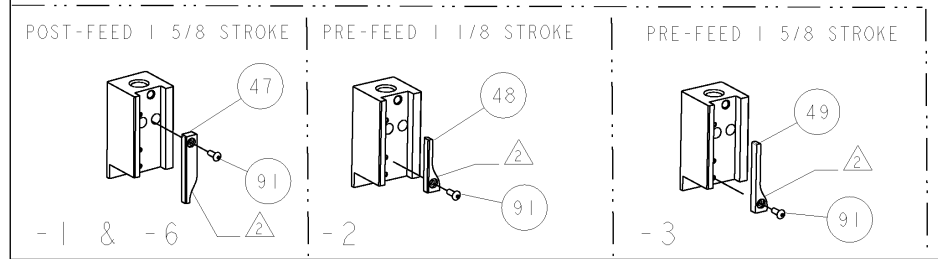
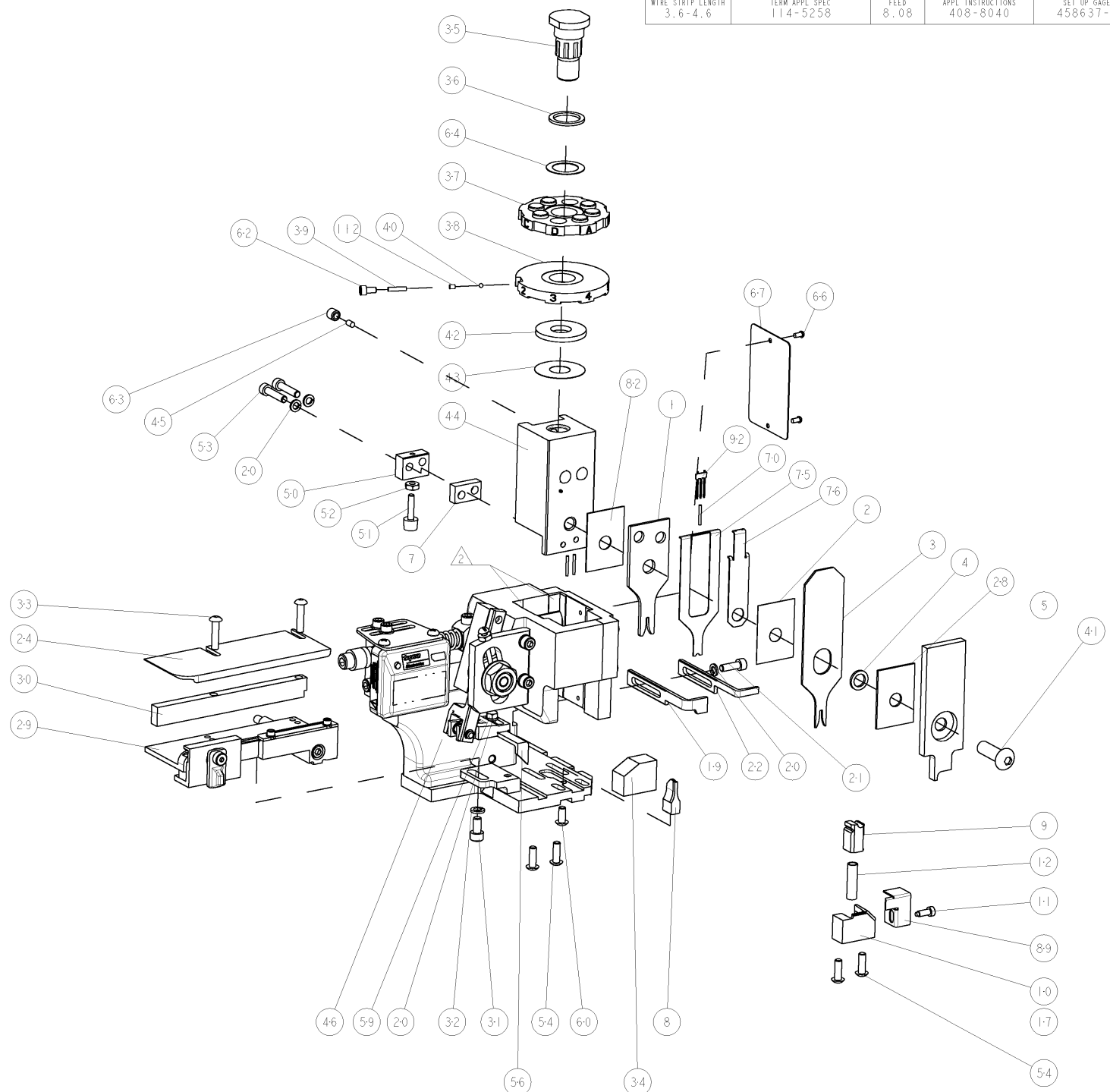
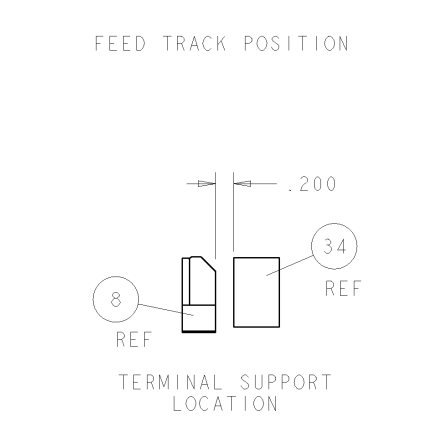
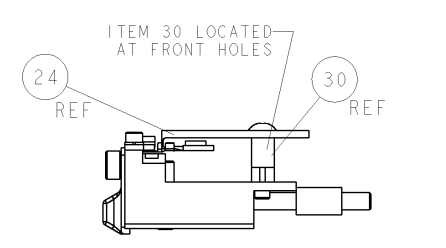
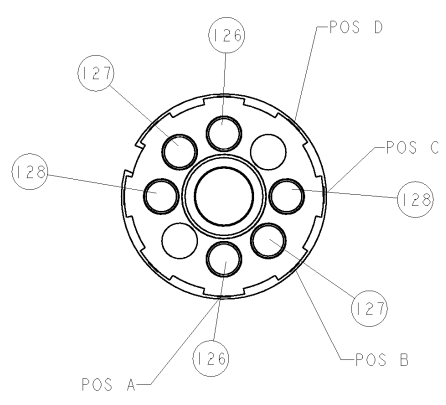

DIMENSIONS: INCHES		TOLERANCES UNLESS OTHERWISE SPECIFIED:		DRAWN: C. REICHELDERFER		DATE: MARCH2006	
0 PLC	+	1 PLC	±0.1	2 PLC	±0.01	3 PLC	±0.001
4 PLC	±0.0001	ANGLES		APPROVED: T. BENCHOFF	DATE: MARCH2006	NAME: T. BENCHOFF	
MATERIAL:				FINISH:			
WEIGHT:				SCALE: 3:5			
CUSTOMER DRAWING				SHEET 1 OF 1			

CUSTOMER VIEWABLE ASSEMBLY

Mouser Electronics

Authorized Distributor

Click to View Pricing, Inventory, Delivery & Lifecycle Information:

[TE Connectivity:](#)

[1852216-2](#)