

L6228 fully-integrated two-phase stepper motor driver

Introduction

Modern motion control applications need more flexibility, which can only be addressed with specialized IC products. The L6228 is a fully-integrated stepper motor driver IC specifically developed to drive a wide range of two-phase (bipolar) stepper motors. This IC is a one-chip, cost-effective solution that includes several unique circuit design features. These features, including a decoding logic that can generate three different stepping sequences, allow the device to be used in many applications, including microstepping. The principal aim of this development project was to produce an easy-to-use, fully-protected power IC. In addition, several key functions, such as protection circuitry and PWM current control, drastically reduce the number of external components to meet requirements for many different applications.

The L6228 is a highly-integrated, mixed-signal power IC that allows the user to easily design a complete motor control system for two-phase bipolar stepper motors. *Figure 1* shows the L6228 block diagram. The IC integrates eight Power DMOS's, a centralized logic circuit that implements the phase generation and a constant t_{OFF} PWM current control technique (quasi-synchronous mode) for each of the two phases of the motor, plus other added features for safe operation and flexibility.

Figure 1. L6228 block diagram

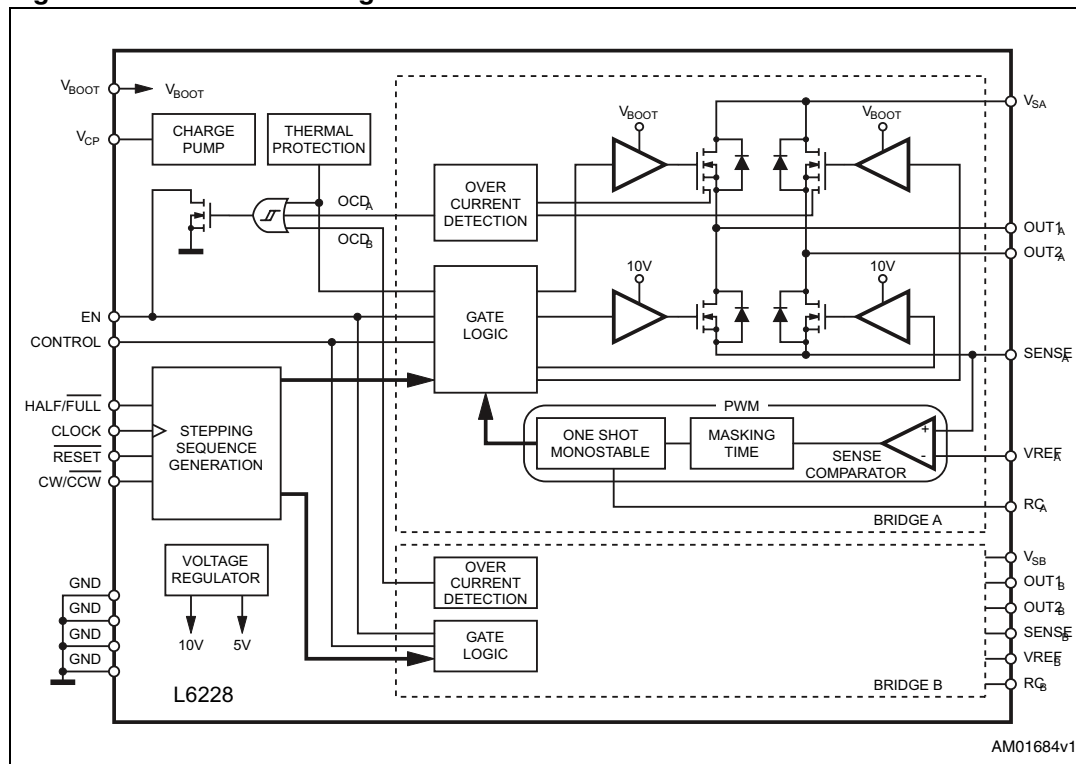

Contents

- 1 Designing an application with L6228 4**
 - 1.1 Current ratings 4
 - 1.2 Voltage ratings and operating range 4
 - 1.3 Choosing the bulk capacitor 6
 - 1.4 Layout considerations 7
 - 1.5 Sensing resistors 9
 - 1.6 External components for the charge pump 10
 - 1.7 Sharing the charge pump circuitry 11
 - 1.8 Reference voltage for PWM current control 12
 - 1.9 Input logic pins 13
 - 1.10 EN pin 13
 - 1.11 Programmable off time monostable 14
 - 1.11.1 Off time selection and minimum on time 16
 - 1.11.2 Decay modes 16
 - 1.12 Overcurrent protection 18
 - 1.13 Power management 21
 - 1.13.1 Maximum output current versus selectable devices 23
 - 1.13.2 Power dissipation and thermal analysis with PractiSPIN™ software .. 23
 - 1.14 Choosing the decay mode 24
 - 1.15 Choosing the stepping sequence 25
 - 1.16 Microstepping 27

- 2 Application example 29**

- Appendix A Demonstration board..... 31**
 - A.1 PractiSPIN™ 31
 - A.2 L6228N evaluation with EVAL6208N..... 32
 - A.2.1 Important notes..... 32
 - A.3 EVAL6228QR 34

- References..... 38**

- Revision history 39**

List of figures

Figure 1.	L6228 block diagram	1
Figure 2.	Supply voltage of high-side gate drivers versus supply voltage	4
Figure 3.	Currents and voltages during the dead time at the beginning of the off time	5
Figure 4.	Voltage at the two outputs at the beginning of the off-time.	6
Figure 5.	Typical application and layout suggestions	8
Figure 6.	Two situations that must be avoided	9
Figure 7.	Charge pump	10
Figure 8.	Sharing the charge-pump circuitry	11
Figure 9.	Obtaining a variable voltage through a PWM output of a μC	12
Figure 10.	Logic input pins	13
Figure 11.	EN input pin	13
Figure 12.	Simplified schematic of the PWM current controller	14
Figure 13.	Output current regulation waveforms	15
Figure 14.	Typical off time vs. C_{OFF} for several values of R_{OFF}	16
Figure 15.	Minimum on time vs. C_{OFF}	16
Figure 16.	Fast decay mode output stage configurations	17
Figure 17.	Slow decay mode output stage configurations	17
Figure 18.	PWM controller loses the current regulation due to minimum on time	18
Figure 19.	PWM controller loses the current regulation due to minimum on time - detail	18
Figure 20.	Simplified circuitry of the overcurrent detection	19
Figure 21.	Overcurrent operation: timing 1	20
Figure 22.	Overcurrent operation: timing 2	20
Figure 23.	Typical disable time vs. C_{EN} for several values of R_{EN}	21
Figure 24.	Typical delay time vs. C_{EN}	21
Figure 25.	IC dissipated power versus output current	22
Figure 26.	Maximum output current vs. selectable devices	23
Figure 27.	Power dissipation and thermal analysis with PractiSPIN™ software	24
Figure 28.	Torque instability in full-step mode.	25
Figure 29.	Balanced half step for low torque ripple	26
Figure 30.	Realizing half-step current shaping	26
Figure 31.	Microstepping application	27
Figure 32.	Microstepping reference voltages, output currents and CLOCK signal	27
Figure 33.	Using fast decay during a high, negative current slope	28
Figure 34.	Application example	30
Figure 35.	PractiSPIN™ PC software	31
Figure 36.	PractiSPIN™ ST7 demonstration board.	32
Figure 37.	EVAL6208N electrical schematic	33
Figure 38.	EVAL6228QR	34
Figure 39.	EVAL6228QR component placement	35
Figure 40.	EVAL6228QR top layer	36
Figure 41.	EVAL6228QR bottom layer	36
Figure 42.	EVAL6228QR electrical schematic	37

1 Designing an application with L6228

1.1 Current ratings

With MOSFET (DMOS) devices, unlike bipolar transistors, the current under short-circuit conditions is, at a first approximation, limited by the $R_{DS(on)}$ of the DMOS themselves and can reach very high values. The L6228's OUT pins and the two V_{SA} and V_{SB} pins are rated for a maximum of 1.4 Arms and 2.8 A peak (typical values), corresponding to a total of 2.8 Arms (5.6 A peak) for the whole IC. These values are meant to avoid damaging the metal structures, including the metallization on the die and bond wires. In practical applications, however, the maximum-allowable current is less than these values, due to power dissipation limits (see [Section 1.13](#)). The device has a built-in overcurrent detection (OCD) that provides protection against short-circuits between the outputs and between an output and ground (see [Section 1.12](#)).

1.2 Voltage ratings and operating range

The L6228 requires a single supply voltage (V_S) for the motor supply. Internal voltage regulators provide the 5 and 10 volts required for the internal circuitry. The operating range for V_S is 8 to 52 V. To prevent the device from operating at an insufficient supply voltage, an undervoltage lockout (UVLO) circuit shuts down the device when the supply voltage falls below 5.5 V; to resume normal operating conditions, V_S must then exceed 6.3 V. The hysteresis is provided to avoid false intervention of the UVLO function during fast V_S ringings. It should be noted, however, that the DMOS' $R_{DS(on)}$ is a function of the V_S supply voltage. In fact, when V_S is less than 10 V, $R_{DS(on)}$ is adversely affected, and this is particularly true for the high-side DMOS's that are driven from the V_{BOOT} supply. This supply is obtained through a charge pump from the internal 10 V supply, which will tend to reduce its output voltage when V_S goes below 10 V. [Figure 2](#) shows the supply voltage of the high-side gate drivers ($V_{BOOT} - V_S$) versus the supply voltage (V_S).

Figure 2. Supply voltage of high-side gate drivers versus supply voltage

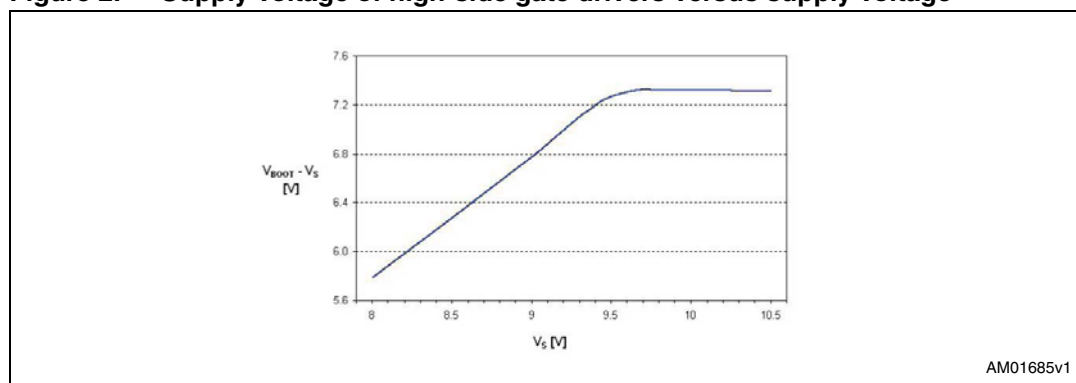

Note that V_S must be connected to both V_{SA} and V_{SB} since the bootstrap voltage (at the V_{BOOT} pin) is the same for the two H-bridges. The integrated DMOS's have a rated drain-source breakdown voltage of 60 V. However, V_S should be kept below 52 V, since in normal working conditions the DMOS's see a V_{ds} voltage that will exceed the V_S supply. In particular, when using the fast-decay mode, at the beginning of the off time (when all the DMOS's are off during dead time) the SENSE pin sees a negative spike due to a non-negligible parasitic inductance of the PCB path from the pin to GND.

This spike is followed by a stable negative voltage due to the drop on R_{SENSE} . One of the two OUT pins of the bridge sees a similar behavior, but with a slightly larger voltage due to the forward recovery time of the integrated freewheeling diode and the forward voltage drop across it (see [Figure 3](#)). The typical duration of this spike is 30 ns. At the same time, the other OUT pin of the same bridge sees a voltage above V_S , due to the PCB inductance and voltage drop across the high-side (integrated) freewheeling diode, as the current reverses direction and flows into the bulk capacitor. It turns out that, in fast decay mode, the highest differential voltage is observed between the two OUT pins of the same bridge, at the beginning of the off time, and this must always be kept below 60 V^(a). The same high-voltage condition exists when a step is made and the direction of the current flow reverses in the bridge.

Figure 3. Currents and voltages during the dead time at the beginning of the off time

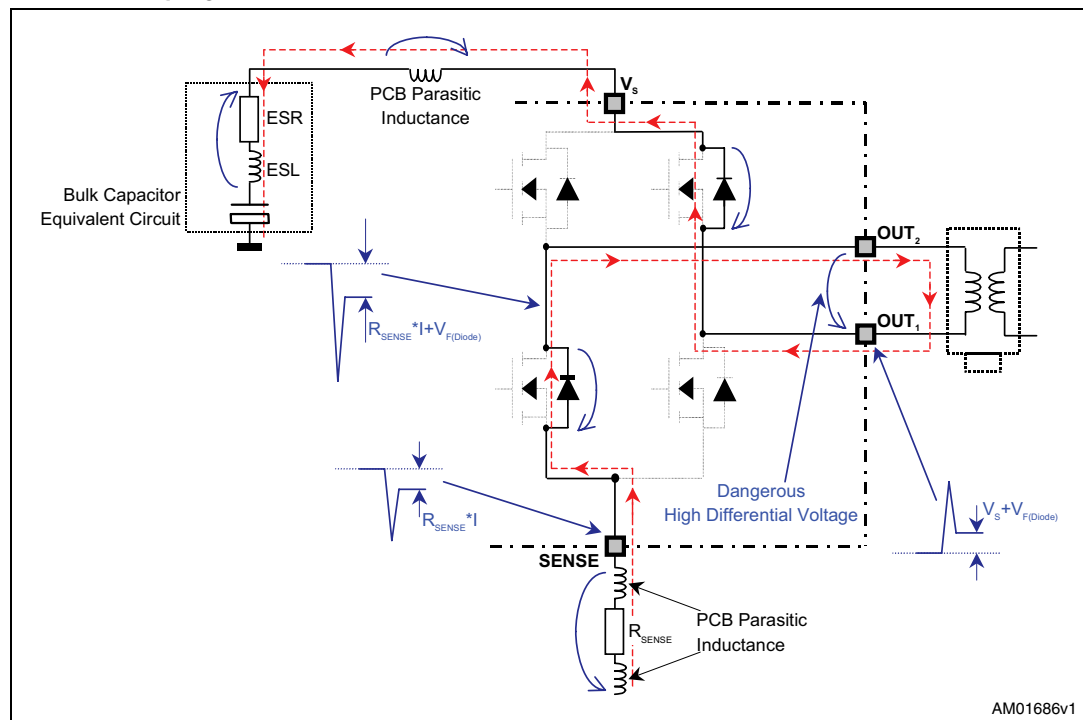

[Figure 4 on page 6](#) shows the voltage waveforms at the two OUT pins referring to a possible practical situation, with a peak output current of 1.4 A, $V_S = 52$ V, $R_{\text{SENSE}} = 0.33 \Omega$, $T_J = 25$ °C (approximately) and a good PCB layout. The below-ground spike amplitude is -2.65 V for one output; the other OUT pin is at about 57 V. In these conditions, the total differential voltage reaches almost 60 V, which is the absolute maximum rating for the DMOS. It is extremely important to keep the differential voltage between two output pins belonging to the same full bridge within rated values. This can be accomplished by correctly selecting the value of the bulk capacitor and equivalent series resistance (ESR), according to the current peaks and chopping style, and by adopting good layout practices to minimize PCB parasitic inductances^(a).

a. Refer to [3] in [References](#).

Figure 4. Voltage at the two outputs at the beginning of the off-time

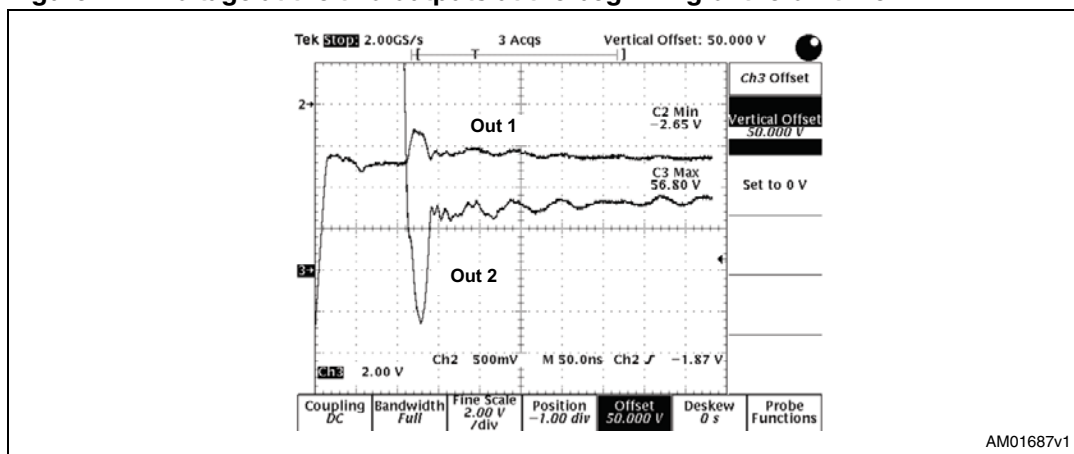

1.3 Choosing the bulk capacitor

Since the bulk capacitor, placed between the V_S and GND pins, is charged and discharged during IC operation, its AC current capability must be greater than the RMS value of the charge/discharge current. This current flows from the capacitor to the IC during the on time (t_{ON}) and from the IC (in fast decay; from the power supply in slow decay) to the capacitor during the off time (t_{OFF}). The RMS value of the current flowing into the bulk capacitor depends on the peak output current, output current ripple, switching frequency, duty cycle and chopping style. It also depends on the characteristics of the power supply. A power supply with poor high-frequency performances (or long, inductive connections to the IC) will cause the bulk capacitor to be recharged slowly: the higher the current control switching frequency, the higher the current ripple in the capacitor; RMS current in the capacitor, however, does not exceed the RMS output current. The bulk capacitor value (C) and the ESR determine the amount of voltage ripple on the capacitor itself and on the IC. In slow decay, neglecting the dead-time and output current ripple, and assuming that during the *on* time the capacitor is not recharged by the power supply, the voltage at the end of the on time is:

Equation 1

$$V_S - I_{OUT} \cdot \left(ESR + \frac{t_{ON}}{C} \right)$$

so the supply voltage ripple is:

Equation 2

$$I_{OUT} \cdot \left(ESR + \frac{t_{ON}}{C} \right)$$

where I_{OUT} is the output current. In fast decay, instead, the recirculating current recharges the capacitor, causing the supply voltage to exceed the nominal voltage. This can be very dangerous if the nominal supply voltage is close to the maximum recommended supply voltage (52 V).

In fast decay the supply voltage ripple is about:

Equation 3

$$I_{OUT} \cdot \left(2 \cdot ESR + \frac{t_{ON} + t_{OFF}}{C} \right)$$

always assuming that the power supply does not recharge the capacitor, and neglecting the output current ripple and the dead-time. Usually (if $C > 100 \mu\text{F}$) the capacitance role is much less than the ESR, in which case the supply voltage ripple can be estimated as:

Equation 4

$$I_{OUT} \cdot ESR$$

Equation 5

$$2 \cdot I_{OUT} \cdot ESR$$

For example, if a maximum ripple of 500 mV is allowed and $I_{OUT} = 1 \text{ A}$, the capacitor ESR should be lower than:

Equation 6

$$ESR < \frac{0.5\text{V}}{1\text{A}} = 500\text{m}\Omega \quad \text{in slow decay}$$

Equation 7

$$ESR < \frac{1}{2} \cdot \frac{0.5\text{V}}{1\text{A}} = 250\text{m}\Omega \quad \text{in fast decay}$$

In fact, current sunk by the V_{SA} and V_{SB} pins of the device is subject to higher peaks due to the reverse recovery charge of the internal freewheeling diodes. The duration of these peaks is very short and can be filtered using a small value (100÷200 nF), good-quality ceramic capacitor connected as close as possible to the V_{SA} , V_{SB} and GND pins of the IC. The bulk capacitor should be chosen with a maximum operating voltage 25% greater than the maximum supply voltage, considering also the power supply tolerances. For example, with a 48 V nominal power supply with 5% tolerance, the maximum voltage will be 50.4 V, and the operating voltage for the capacitor should be at least 63 V.

1.4 Layout considerations

Working with devices that combine high-power switches and control logic in the same IC, special attention has to be paid to the layout of the PCB. In extreme cases, Power DMOS commutation can induce noise that may cause improper operation in the logic section of the device. Noise can be radiated by high dV/dt nodes or high dI/dt paths, or conducted through GND or supply connections. Logic connections, especially high-impedance nodes (actually all logic inputs, see [Section 1.9](#)), must be kept far from switching nodes and paths. With the L6228 in particular, the external components for the charge-pump circuitry should be connected together through short paths, since these components are subject to voltage and current switching at a relatively high frequency (600 kHz). The primary means of minimizing conducted noise is to work on a good GND layout (see [Figure 5 on page 8](#)).

Figure 5. Typical application and layout suggestions

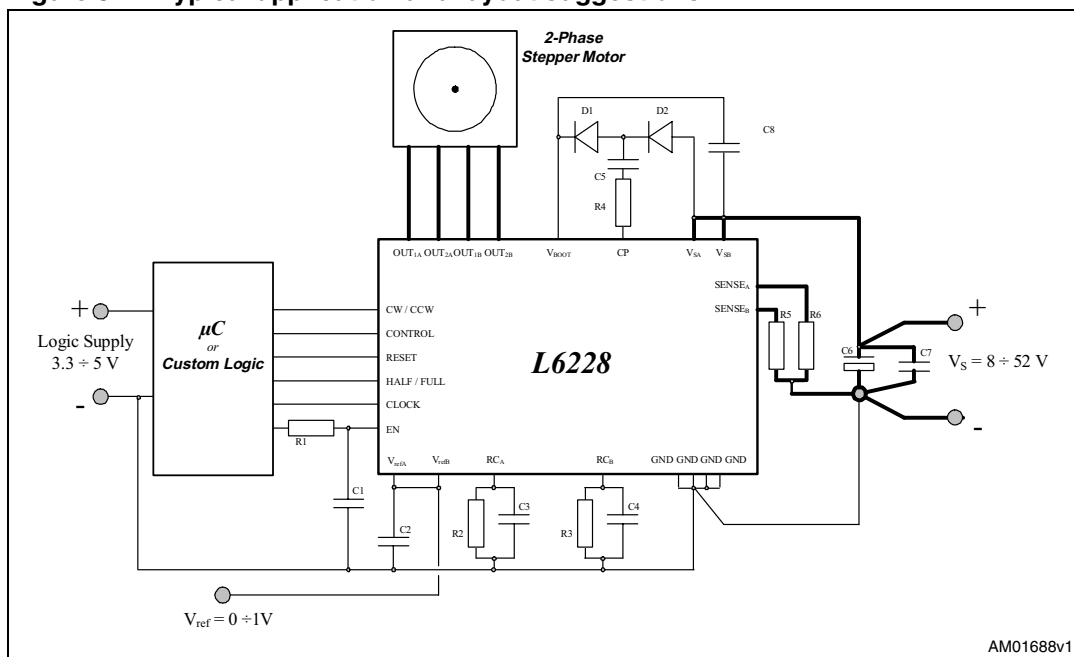

The high current GND tracks (the tracks connected to the sensing resistors) must be connected directly to the negative terminal of the bulk capacitor. A good quality, high-frequency bypass capacitor is also required (typically a 100-200 nF ceramic would suffice), since electrolytic capacitors show a poor high-frequency performance. Both bulk electrolytic and high-frequency bypass capacitors have to be connected with short tracks to V_{SA} , V_{SB} and GND. On the L6228 the GND pins are the logic GND since only the quiescent current flows through them. The logic GND and power GND should be connected together in a *single point*, the bulk capacitor, to keep noise in the power GND from affecting the logic GND. Specific care should be paid layouting the path from the SENSE pins through the sensing resistors to the negative terminal of the bulk capacitor (power ground). These tracks must be as short as possible to minimize parasitic inductances that can cause dangerous voltage spikes on the SENSE and OUT pins (see [Section 1.2](#)); for the same reason the capacitors on V_{SA} , V_{SB} and GND should be very close to the GND and supply pins. Refer to [Section 1.5](#) for information on selecting the sense resistors. The traces connected to V_{SA} , V_{SB} , SENSE_A, SENSE_B, and the four OUT pins must be designed with adequate width, since high currents flow through these traces, and layer changes should be avoided. Should a layer change prove necessary, multiple and large via holes have to be used. A wide GND copper area can be used to improve heat removal, thus reducing thermal resistance.

[Figure 6 on page 9](#) shows two typical situations that must be avoided. An important consideration regarding the location of the bulk capacitors is the ability to absorb the inductive energy from the load, without allowing the supply voltage to exceed the maximum rating. The diode shown in [Figure 6](#) prevents the recirculation current from reaching the capacitors and will result in a high voltage on the IC pins that can damage the device. Having a switch or a power connection that can disconnect the capacitors from the IC, while there is still current in the motor, will also result in a high voltage transient since there is no capacitance to sink the recirculating current.

Figure 6. Two situations that must be avoided

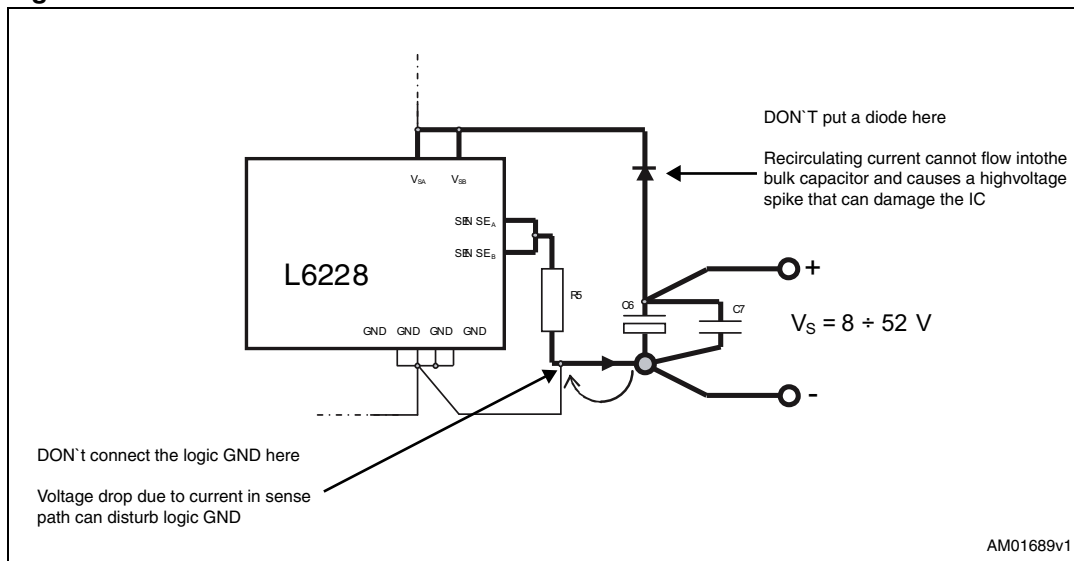

1.5 Sensing resistors

Each motor winding current flows through the corresponding sensing resistor, causing a voltage drop that is used, by the logic, to control the peak value of the load current. Two important points must be taken into account when choosing the R_{SENSE} value.

- The sensing resistor dissipates energy and provides dangerous negative voltages on the SENSE pin during the current recirculation. For this reason, the resistance of this component should be kept low.
- The voltage drop across R_{SENSE} is compared with the reference voltage (on the V_{ref} pin) by the internal comparator. The lower the R_{SENSE} value, the higher the peak current error due to noise on the V_{ref} pin and to the input offset of the current sense comparator: R_{SENSE} values that are too small must be avoided.

A good compromise is to calculate the sensing resistor value so that the voltage drop, corresponding to the peak current in the load (I_{peak}), is about 0.5 V: $R_{SENSE} = 0.5 V / I_{peak}$.

The sensing resistor must be of a non-inductive type in order to avoid dangerous negative spikes on the SENSE pins. Wire-wound resistors cannot be used here, while metallic film resistors are recommended for their high peak current capability and low inductance. For the same reason, the connections between the SENSE pins, C6, C7, V_{SA} , V_{SB} and GND pins (see [Figure 5 on page 8](#)) must be as short as possible (also see [Section 1.4](#)).

The average power dissipated by the sensing resistor is:

- Fast decay recirculation: $P_R \approx I_{rms}^2 \cdot R_{SENSE}$
- Slow decay recirculation: $P_R \approx I_{rms}^2 \cdot R_{SENSE} \cdot D$

where D is the duty-cycle of the PWM current control and I_{rms} is the RMS value of the load current. Nevertheless, the peak value of the dissipated power should be taken into account when choosing the power rating of the sensing resistor.

Equation 8

$$P_R \approx I_{pk}^2 \cdot R_{SENSE}$$

where I_{pk} is the peak value of the load current.

Using multiple resistors in parallel will help obtain the required power rating with standard resistors and reduce the inductance.

The R_{SENSE} tolerance reflects on the peak current error: 1% resistors should be preferred. [Table 1](#) shows the recommended values for R_{SENSE} (to obtain a 0.5-V drop) and power ratings for typical examples of current peak values.

Table 1. R_{SENSE} recommended values

I_{pk}	R_{SENSE} value [Ω]	R_{SENSE} power rating [W]	Alternatives
0.25	2	0.125	
0.5	1	0.25	
1	0.5	0.5	2 X 1 Ω , 0.25 W paralleled

1.6 External components for the charge pump

An internal oscillator, with its output at the CP pin, switches from GND to 10 V with a typical frequency of 600 kHz ([Figure 7](#)).

Figure 7. Charge pump

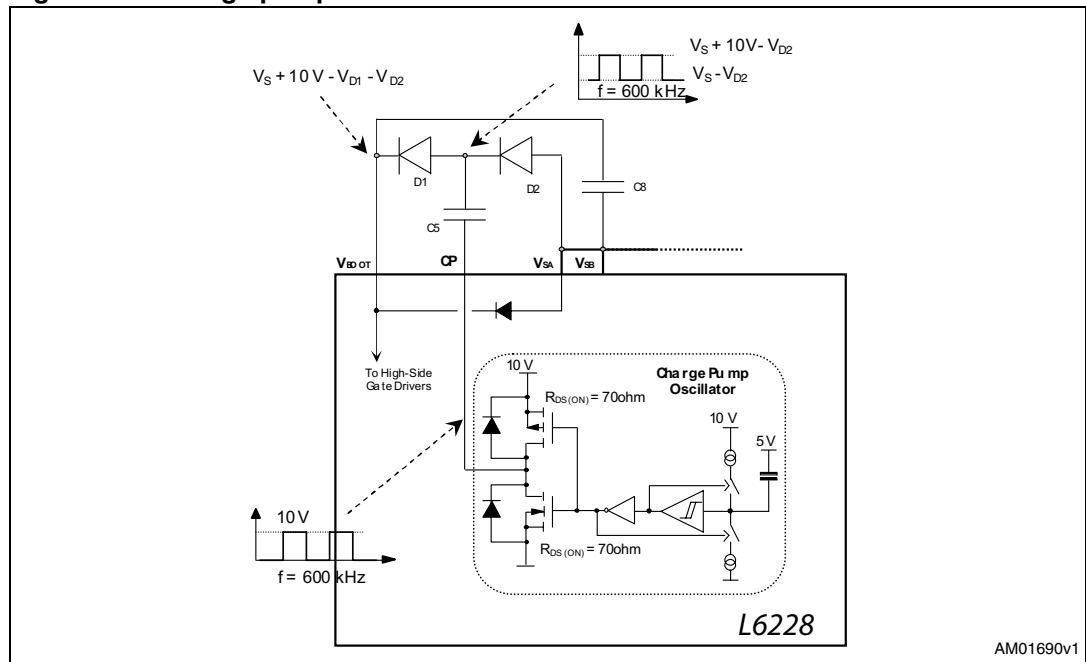

When the oscillator output is at ground, C_5 is charged by V_S through D_2 . When it rises to 10 V, D_2 is reverse-biased and the charge flows from C_5 to C_8 through D_1 , so the V_{BOOT} pin, after a few cycles, reaches the maximum voltage of $V_S + 10 V - V_{D1} - V_{D2}$, which supplies the high-side gate drivers.

With a differential voltage between V_S and V_{BOOT} of about 9 V and both bridges switching at 50 kHz, the typical current drawn by the V_{BOOT} pin is 1.85 mA.

To minimize interferences with the rest of the circuit, care must be taken in realizing the PCB layout of the C5, D1 and D2 connections (also see [Section 1.4](#)). The recommended values for the charge pump circuitry are:

- D1, D2: 1N4148
- C5: 10 nF, 100 V ceramic
- C8: 20 nF, 25 V ceramic

Due to the high charge-pump frequency, fast diodes are required. When connecting the cold side of the bulk capacitor (C8) to V_S instead of GND, the average current in the external diodes during operation is less than 10 mA; at startup (when V_S is provided to the IC) it is less than 200 mA while the reverse voltage is about 10 V in all conditions. 1N4148 diodes withstand about 200 mA of DC current (1 A peak), and the maximum reverse voltage is 75 V, so they should fit for the majority of applications.

1.7 Sharing the charge pump circuitry

If more than one device is used in the application, the charge pump from one L6228 can be used to supply the V_{BOOT} pins of several ICs. The unused CP pins on the slaved devices are left unconnected, as shown in [Figure 8](#). A 100 nF capacitor (C8) should be connected to the V_{BOOT} pin of each device.

The supply voltage pins V_S of the devices sharing the charge pump must be connected together.

The higher the number of devices sharing the same charge pump, the lower the differential voltage available for the gate drive ($V_{BOOT} - V_S$), causing a higher $R_{DS(on)}$ for the high-side DMOS, and as such a higher dissipating power.

Better performance can also be obtained using a 33 nF capacitor for C5 and Schottky diodes (BAT47 are recommended).

Having more than three or four devices sharing the same charge-pump circuitry is not recommended since this will reduce the V_{BOOT} voltage and increase the high-side MOSFET's on-resistance, and therefore the power dissipation.

Figure 8. Sharing the charge-pump circuitry

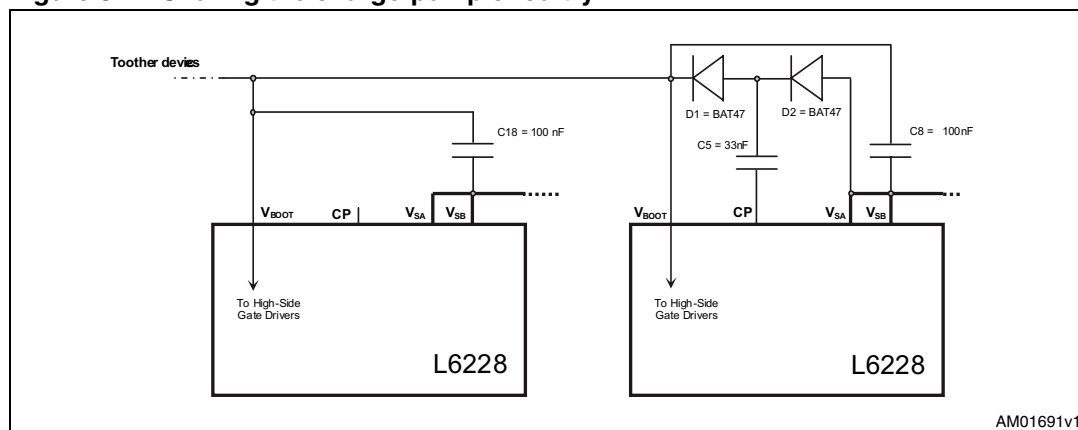

1.8 Reference voltage for PWM current control

The device has two analog inputs, V_{refA} and V_{refB} , connected to the internal sense comparators, to control the peak value of the motor current through the integrated PWM circuitry. In typical applications, these pins are connected together to obtain the same current in the two motor windings (one exception is the microstepping operation; see [Section 1.16](#)). A fixed reference voltage can be easily obtained through a resistive divider from an available 5 V voltage rail (maybe the one supplying the μC or the rest of the application) and GND.

A very simple way to obtain a variable voltage without using a DAC is to low-pass filter a PWM output of a μC (see [Figure 9](#)).

Assuming that the PWM output swings from 0 to 5 V, the resulting voltage will be:

Equation 9

$$V_{ref} = \frac{5V \cdot D_{\mu C} \cdot R_{DIV}}{R_{LP} + R_{DIV}}$$

where $D_{\mu C}$ is the duty-cycle of the PWM output of the μC .

Assuming that the output impedance of the μC is lower than 1 k Ω , with $R_{LP} = 56$ k Ω , $R_{DIV} = 15$ k Ω , $C_{LP} = 10$ nF and a μC PWM switching from 0 to 5 V at 100 kHz, the low-pass filter's time constant is about 0.12 ms and the remaining ripple on the V_{ref} voltage will be about 20 mV. Using higher values for R_{LP} , R_{DIV} and C_{LP} will reduce the ripple, but the reference voltage will take more time to vary after changing the duty-cycle of the μC PWM, and too-high values of R_{LP} will also increase the impedance of the V_{ref} net at low frequencies, causing a poor noise immunity.

As sensing resistor values are typically kept small, a small noise on the V_{ref} input pins might cause a considerable error in the output current. It is recommended to decouple these pins with ceramic capacitors of some tens of nF, placed very close to the V_{ref} and GND pins. Note that the V_{ref} pins cannot be left unconnected, while, if connected to GND, zero current is not guaranteed due to voltage offset in the sense comparator. The best way to cut down the IC's power consumption and clear the load current is by pulling down the EN pin. In slow decay, with a very small reference voltage, the PWM's integrated circuitry can lose control of the current due to the minimum-allowed duration of t_{ON} (see [Section 1.11](#)).

Figure 9. Obtaining a variable voltage through a PWM output of a μC

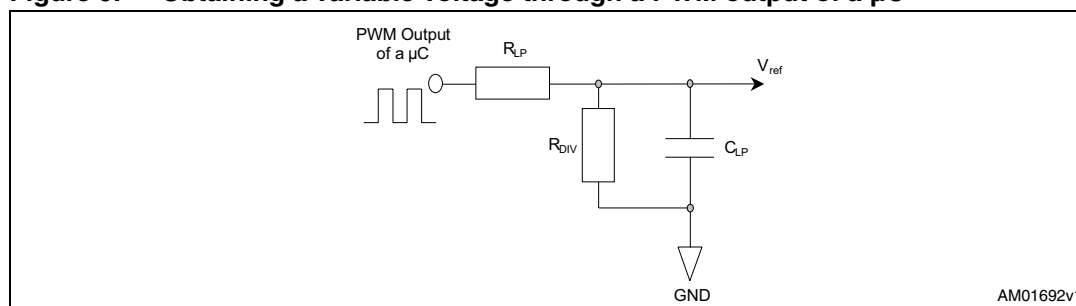

1.9 Input logic pins

CW/CCW, CONTROL, RESET, HALF/FULL, CLOCK are CMOS/TTL-compatible logic input pins. The input comparator has been realized with hysteresis to ensure the required noise immunity is met. Typical values for turn-on and turn-off thresholds are $V_{th,ON} = 1.8\text{ V}$ and $V_{th,OFF} = 1.3\text{ V}$. As shown in [Figure 10](#), these pins are ESD-protected (2 kV human-body electro-static discharge), and can be directly connected to the logic outputs of a μC ; a series resistor is generally not recommended as it could cause inducted noise and disturb the inputs. All logic pins enforce a specific behavior and cannot be left unconnected.

Figure 10. Logic input pins

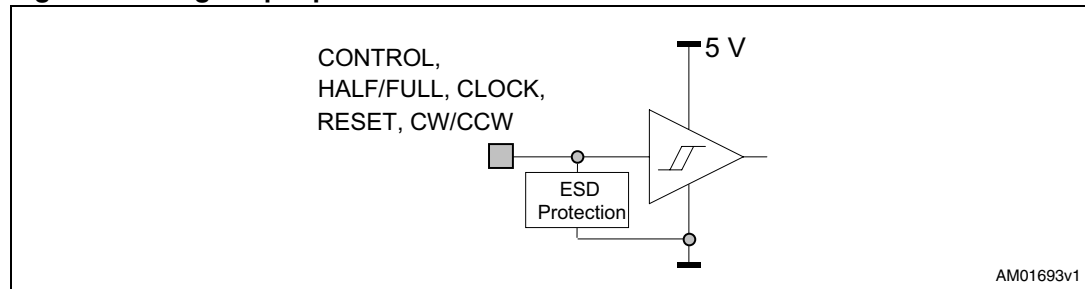

1.10 EN pin

The EN pin is bi-directional: as an input, with a comparator similar to the other logic input pins (TTL/CMOS with hysteresis), it controls the state of the Power DMOS. When this pin is at a low logic level, all the Power DMOS's are turned off. The EN pin is also connected to the open-drain output of the protection circuit that will pull the pin to GND if overcurrent or over-temperature conditions exist. For this reason, the EN pin must be driven through a series resistor of 2.2 k Ω minimum (for 5 V logic), to allow the voltage at the pin to be pulled below the turn-off threshold.

A capacitor (C1 in [Figure 5 on page 8](#)) connected between the EN pin and GND is also recommended to reduce the RMS value of the output current when overcurrent conditions persist (see [Section 1.12](#)). The EN pin must not be left unconnected.

Figure 11. EN input pin

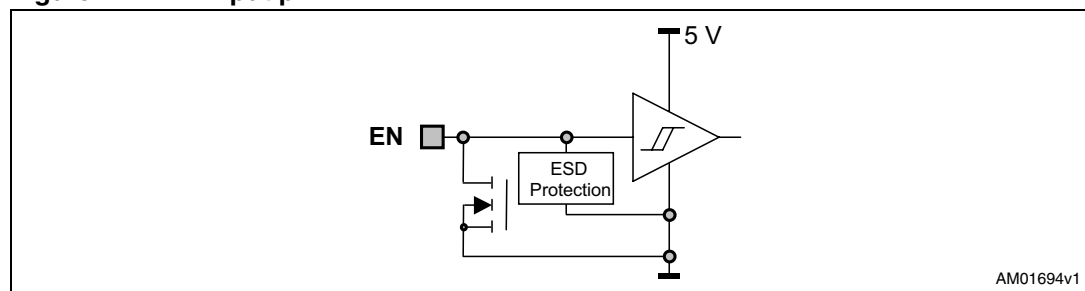

1.11 Programmable *off* time monostable

The L6228 includes a constant *off* time PWM current controller for each of the two bridges. The current control circuit senses the bridge current by sensing the voltage drop across an external sense resistor connected between the source of the two lower power MOSFET transistors and ground, as shown in *Figure 12*. As the current in the motor builds up, the voltage across the sense resistor increases proportionally. When the voltage drop across the sense resistor becomes greater than the voltage at the reference input (V_{refA} or V_{refB}), the sense comparator triggers the monostable, switching the bridge off. The power MOSFETs remain off for the time set by the monostable, and the motor current recirculates as defined by the selected decay mode, described in the next section. When the monostable times out, the bridge will again turn on. Since the internal dead time used to prevent cross-conduction in the bridge delays the turn-on of the power MOSFETs, the effective *off* time is the sum of the monostable time plus the dead time.

Figure 12. Simplified schematic of the PWM current controller

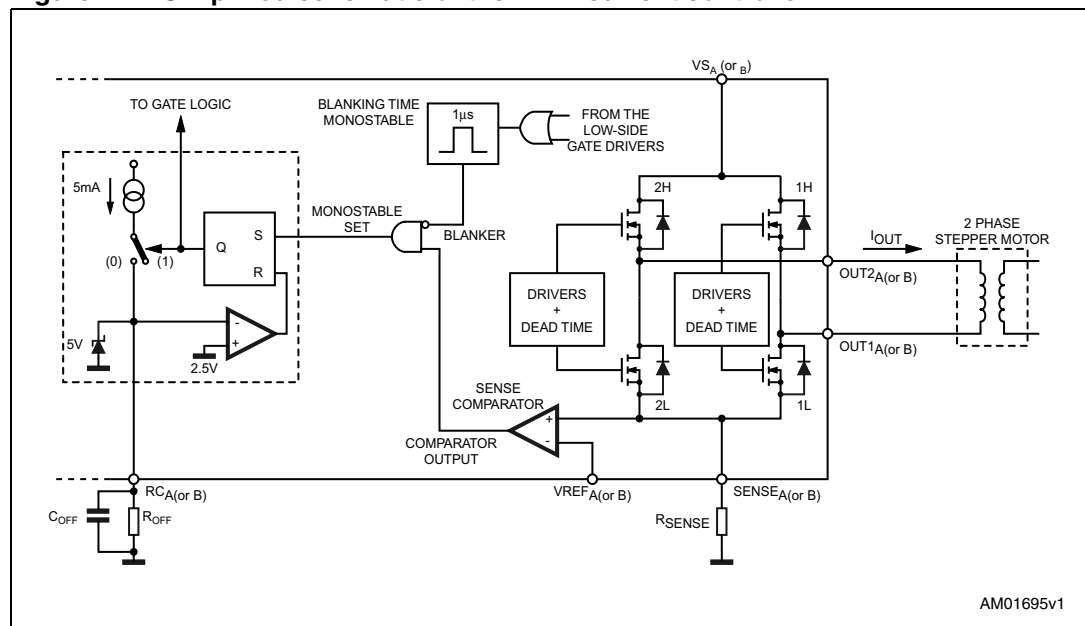

Figure 13 on page 15 shows the typical operating waveforms of the output current, the voltage drop across the sensing resistor, the RC pin voltage and the status of the bridge. More details regarding the synchronous rectification and the output stage configuration are included in the next section.

Immediately after the power MOSFET turns on, a high peak current flows through the sensing resistor due to the reverse recovery of the freewheeling diodes. The L6228 provides a $1 \mu s$ blanking time, t_{BLANK} , that inhibits the comparator output so that this current spike cannot prematurely re-trigger the monostable.

Figure 13. Output current regulation waveforms

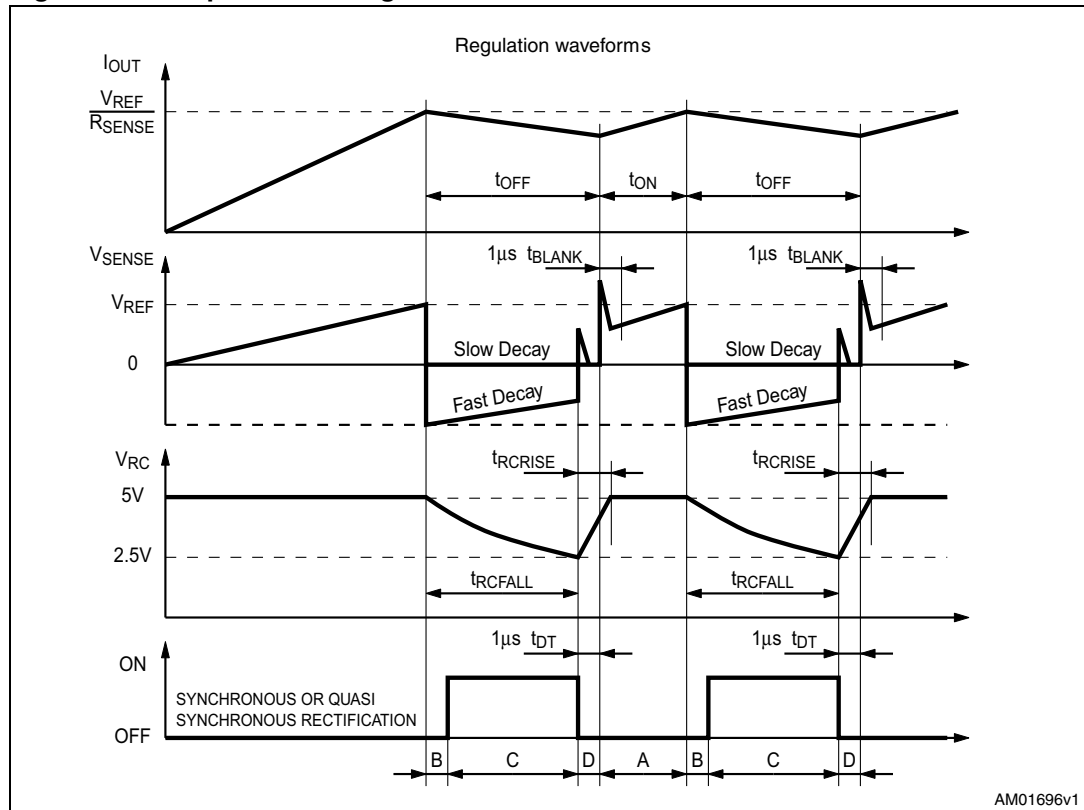

Figure 14 on page 16 shows the magnitude of the off time t_{OFF} versus the C_{OFF} and R_{OFF} values. It can be approximately calculated from the equations:

- $t_{RCFALL} = 0.6 \cdot R_{OFF} \cdot C_{OFF}$
- $t_{OFF} = t_{RCFALL} + t_{DT} = 0.6 \cdot R_{OFF} \cdot C_{OFF} + t_{DT}$

where R_{OFF} and C_{OFF} are the external component values and t_{DT} is the internally-generated dead time with:

- $20 \text{ k}\Omega \leq R_{OFF} \leq 100 \text{ k}\Omega$
- $0.47 \text{ nF} \leq C_{OFF} \leq 100 \text{ nF}$
- $t_{DT} = 1 \text{ }\mu\text{s}$ (typical value)

Therefore:

- $t_{OFF(MIN)} = 6.6 \text{ }\mu\text{s}$
- $t_{OFF(MAX)} = 6 \text{ ms}$

These values allow a sufficient range of t_{OFF} to implement the drive circuit for most motors.

The capacitor value chosen for C_{OFF} also affects the rise time t_{RCRISE} of the voltage at the pin's RC_A (or RC_B). The rise time t_{RCRISE} will only be an issue if the capacitor is not completely charged before the next time the monostable is triggered. Therefore, the on time t_{ON} , which depends on the motors and supply parameters, has to be longer than t_{RCRISE} to allow the PWM stage to correctly regulate the current. Furthermore, the on time t_{ON} cannot be shorter than the minimum on time $t_{ON(MIN)}$.

Equation 10

$$\begin{cases} t_{ON} > t_{ON(MIN)} = 1.5\mu s \text{ (typ. value)} \\ t_{ON} > t_{RCRISE} - t_{DT} \end{cases}$$

Equation 11

$$t_{RCRISE} = 600 \cdot C_{OFF}$$

1.11.1 Off time selection and minimum on time

Figure 15 shows the lower limit for the on time t_{ON} in order to obtain a good PWM current regulation capacity. It has to be said that t_{ON} is always longer than $t_{ON(MIN)}$ because the device imposes this condition, but it can be shorter than $t_{RCRISE} - t_{DT}$. In this last case, the device continues to work but the off time t_{OFF} is not more constant.

Therefore, a small C_{OFF} value gives more flexibility for the applications (allows a shorter on time and, therefore, a higher switching frequency), but the smaller the value for C_{OFF} the more influential the noises on the circuit performance will be.

Figure 14. Typical off time vs. C_{OFF} for several values of R_{OFF} Figure 15. Minimum on time vs. C_{OFF}

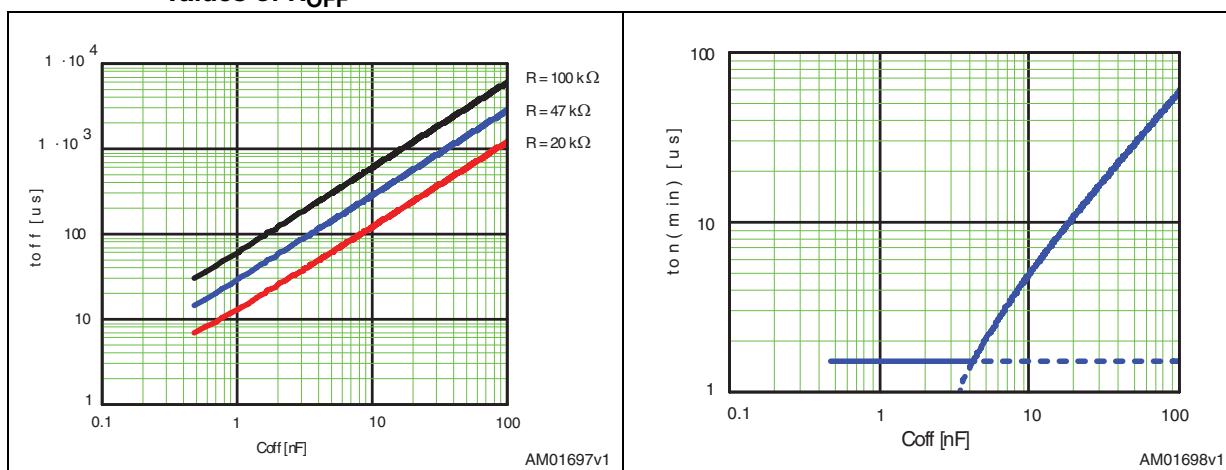

1.11.2 Decay modes

The CONTROL input is used to select the behavior of the bridge during the off time. When the CONTROL pin is low, the fast decay mode is selected and both transistors in the bridge are switched off during the off time. When the CONTROL pin is high, the slow decay mode is selected and only the low-side transistor of the bridge is switched off during the off time.

Figure 16 on page 17 shows the operation of the bridge in fast decay mode. At the start of the off time, both power MOSFETs are switched off and the current recirculates through the two opposite freewheeling diodes. The current decays with a high di/dt since the voltage across the coil is essentially the power supply voltage. After the dead time, the lower power MOSFET in parallel with the conducting diode is turned on in synchronous rectification mode. In applications where the motor current is low, it is possible that the current decays completely to zero during the off time. At this point, if both power MOSFETs were operating in the synchronous rectification mode, it would be possible for the current to build in the opposite direction. To prevent this, only the lower power MOSFET is operated in synchronous rectification mode.

This operation is called *quasi synchronous rectification*. When the monostable times out, the

power MOSFETs are turned on again after some delay set by the dead time to prevent cross-conduction.

Figure 17 shows the operation of the bridge in slow decay mode. At the start of the *off* time, the lower power MOSFET is switched off and the current recirculates around the upper half of the bridge. Since the voltage across the coil is low, the current decays slowly. After the dead time, the upper power MOSFET is operated in the synchronous rectification mode. When the monostable times out, the lower power MOSFET is turned on again after some delay set by the dead time to prevent cross-conduction.

Figure 16. Fast decay mode output stage configurations

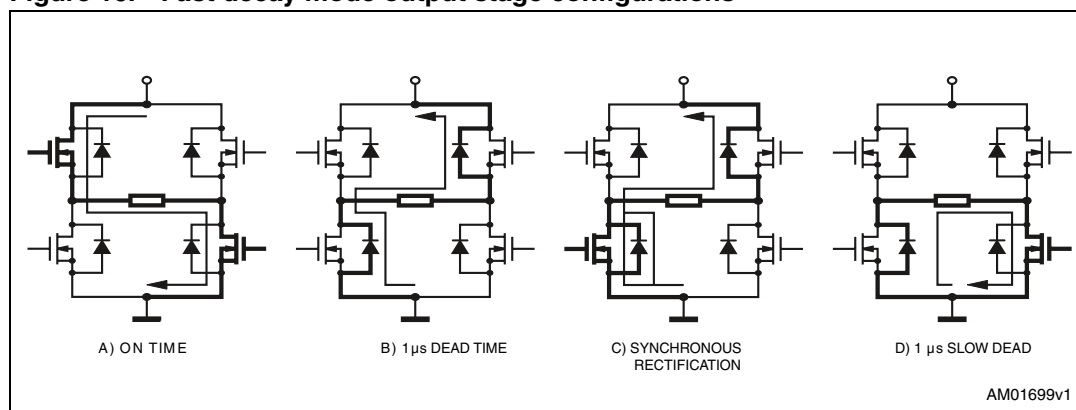
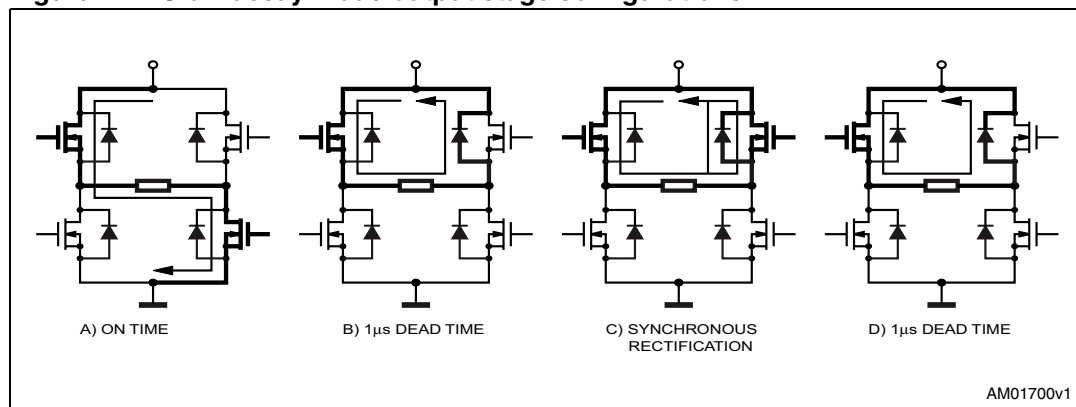

Figure 17. Slow decay mode output stage configurations



In some conditions (short *off* time, very low regulated current, high motor winding L/R) the system may need an *on* time shorter than 1.5 μs . In such a case, the PWM current controller can lose the regulation.

Figure 18 and Figure 19 on page 18 show the operation of the circuit in this condition. When the current first reaches the threshold, the bridge is turned off for a fixed time and the current decays. During the following *on* time, the current increases above the threshold, but the bridge cannot be turned off until the minimum 1.5 μs *on* time has expired. Since the current increases more during each *on* time than it decays during the *off* time, it keeps growing during each cycle, with a steady-state asymptotic value set by the duty cycle and load DC resistance.

The resulting peak current will be:

Equation 12

$$I_{pk} = V_S \cdot \frac{D}{R_{LOAD}}$$

where $D = t_{ON} / (t_{ON} + t_{OFF})$ is the duty cycle and R_{LOAD} is the load DC resistance.

Figure 18. PWM controller loses the current regulation due to minimum on time

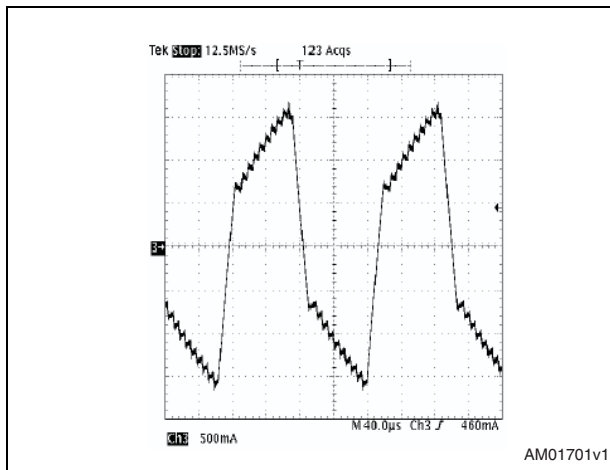
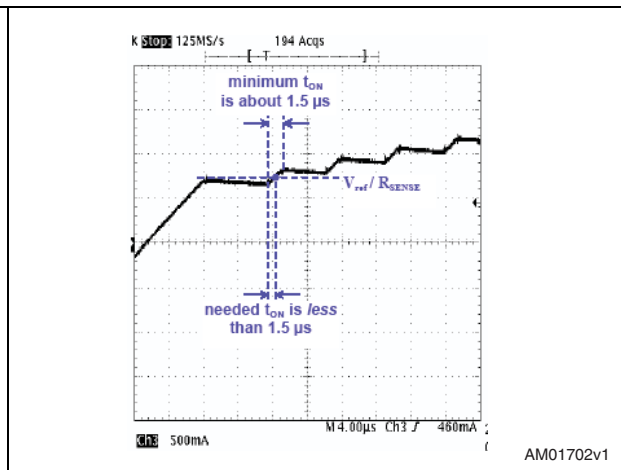

Figure 19. PWM controller loses the current regulation due to minimum on time - detail



1.12 Overcurrent protection

To implement an overcurrent protection, a dedicated overcurrent detection (OCD) circuitry (see [Figure 20 on page 19](#) for a simplified schematic) senses the current in each high side. The power DMOS's are actually made up of thousands of individual identical cells, each carrying a fraction of the total current flowing. The current sensing element, connected in parallel to the power DMOS, is made with only a few such cells, having a 1:N ratio compared to the power DMOS. The total drain current is split between the output and the sense element according to the cell ratio. The sensed current is, then, a small fraction of the output current and will not contribute significantly to power dissipation.

Figure 20. Simplified circuitry of the overcurrent detection

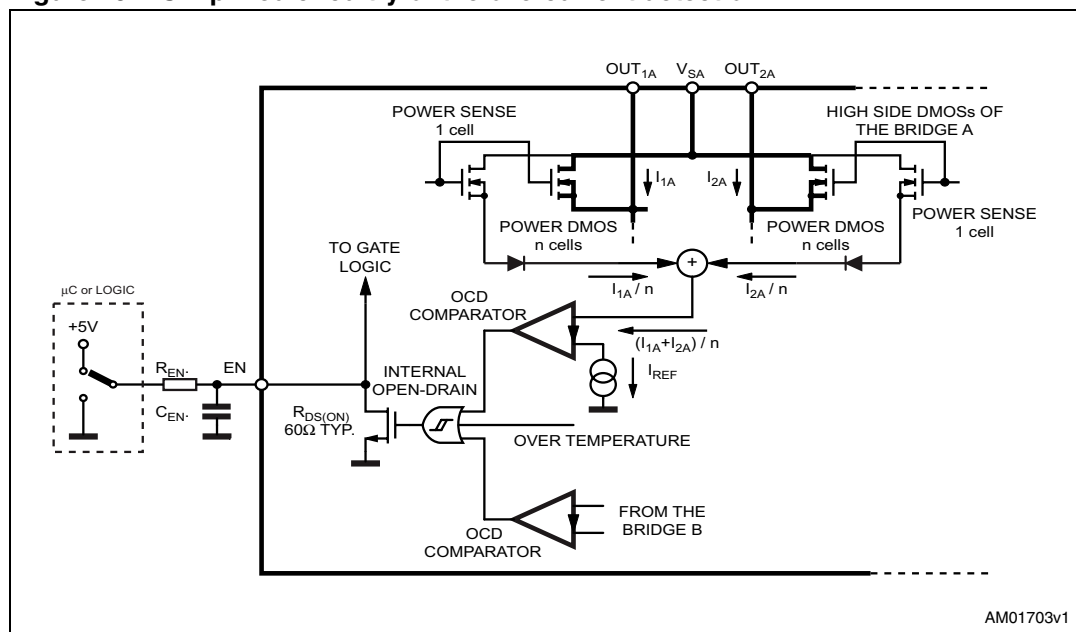

This sensed current is compared to an internally-generated reference to detect an overcurrent condition. An internal open-drain MOSFET turns on when the sum of the currents in the bridges 1A and 2A or 1B and 2B reaches the threshold (2.8 A typical value); the open drain is internally-connected to the EN pin. To ensure an overcurrent protection, this pin should be connected to an external RC network ([Figure 20](#)).

[Figure 21](#) and [Figure 22](#) on page 20 show the device operating in an overcurrent condition (short to ground). When an overcurrent is detected, the internal open-drain MOSFET pulls the EN pin to GND, switching off all 8 power DMOS's of the device and allowing the current to decay. If an overcurrent conditions persists, like a short to ground or a short between two output pins, the external RC network on the EN pin (see [Figure 20](#)) reduces the RMS value of the output current by imposing a fixed disable time after each overcurrent occurrence. The values of R_{EN} and C_{EN} are selected to ensure proper operation of the device during a short-circuit condition. When the current flowing through the high-side DMOS reaches the OCD threshold (2.8 A typ.), after an internal propagation delay ($t_{OCD(ON)}$) the open drain starts discharging C_{EN} . When the EN pin voltage falls below the turn-off threshold ($V_{TH(OFF)}$), all the power DMOS's turn off after the internal propagation delay ($t_{D(OFF)EN}$). The current begins to decay as it circulates through the freewheeling diodes. Since the DMOS's are off, there is no current flowing through them and no current to sense; therefore, the OCD circuit, after a short delay ($t_{OCD(OFF)}$), switches the internal open-drain device off, and R_{EN} can charge C_{EN} . When the voltage at the EN pin reaches the turn-on threshold ($V_{TH(ON)}$), after the $t_{D(ON)EN}$ delay, the DMOS's turn on and the current restarts. Even if the maximum output current can be very high, the external RC network provides a disable time ($t_{DISABLE}$) to ensure a safe RMS value (see [Figure 22](#)).

Figure 21. Overcurrent operation: timing 1

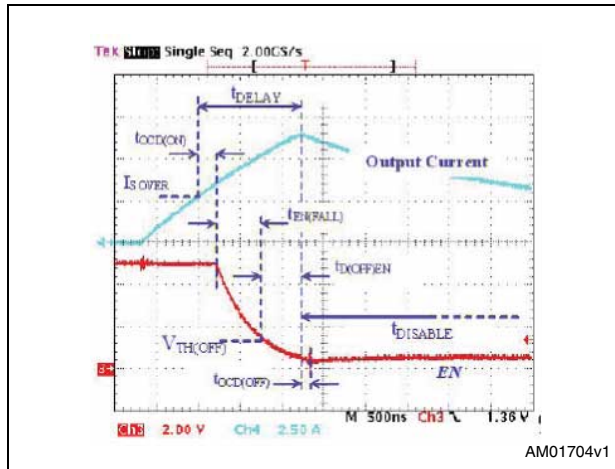
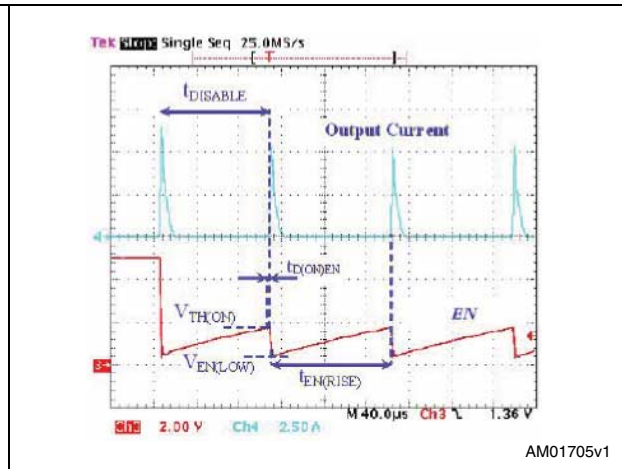

Figure 22. Overcurrent operation: timing 2



The maximum value reached by the current depends on its slew rate, and thus on the state of the short-circuit, the supply voltage, and on the total intervention delay (t_{DELAY}). One can see that after the first current peak, the maximum value reached by the output current decreases; this is because the capacitor on the EN pin is discharged starting from a lower voltage, resulting in a shorter t_{DELAY} .

The following approximate relations estimate the disable time and the first OCD intervention delay after the short-circuit (worst case).

The time the device remains disabled is:

Equation 13

$$t_{DISABLE} = t_{OCD(OFF)} + t_{EN(RISE)} + t_{D(ON)EN}$$

where:

Equation 14

$$t_{EN(RISE)} = R_{EN} \cdot C_{EN} \cdot \ln \frac{V_{DD} - V_{EN(LOW)}}{V_{DD} - V_{TH(ON)}}$$

$V_{EN(LOW)}$ is the minimum voltage reached by the EN pin and can be estimated by the relation:

Equation 15

$$V_{EN(LOW)} = V_{TH(OFF)} \cdot e^{-\frac{t_{D(OFF)EN} + t_{OCD(OFF)}}{R_{OPDR} \cdot C_{EN}}}$$

The total intervention time is:

Equation 16

$$t_{DELAY} = t_{OCD(ON)} + t_{EN(FALL)} + t_{D(OFF)EN}$$

where:

Equation 17

$$t_{EN(FALL)} = R_{OPDR} \cdot C_{EN} \cdot \ln \frac{V_{DD}}{V_{TH(OFF)}}$$

$t_{OCD(OFF)}$, $t_{OCD(ON)}$, $t_{D(ON)EN}$, $t_{D(OFF)EN}$ and R_{OPDR} are device-intrinsic parameters and V_{DD} is the pull-up voltage applied to R_{EN} .

The external RC network, C_{EN} in particular, must be selected to obtain a reasonable fast OCD intervention (short t_{DELAY}) and a safe disable time (long $t_{DISABLE}$). *Figure 23* and *Figure 24* show both $t_{DISABLE}$ and t_{DELAY} as a function of C_{EN} : at least 100 μs for $t_{DISABLE}$ are recommended, keeping the delay time between 1 and 2 μs at the same time.

The internal open drain can also be turned on if the device experiences an over-temperature (OVT) condition. The OVT will cause the device to shut down when the die temperature exceeds the OVT threshold ($T_J > 165^\circ C$ typ.). Since the OVT is also connected directly to the gate-drive circuit (see *Figure 1 on page 1*), all the Power DMOS's will shut down, even if the EN pin voltage is still over $V_{th(OFF)}$. When the junction temperature falls below the OVT turn-off threshold (150 $^\circ C$ typ.), the open drain turns off, C_{EN} is recharged up to $V_{TH(ON)}$ and the Power DMOS's are turned back on.

Figure 23. Typical disable time vs. C_{EN} for several values of R_{EN}

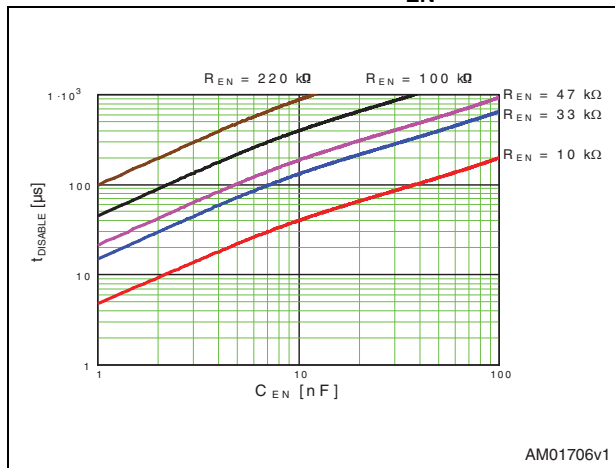
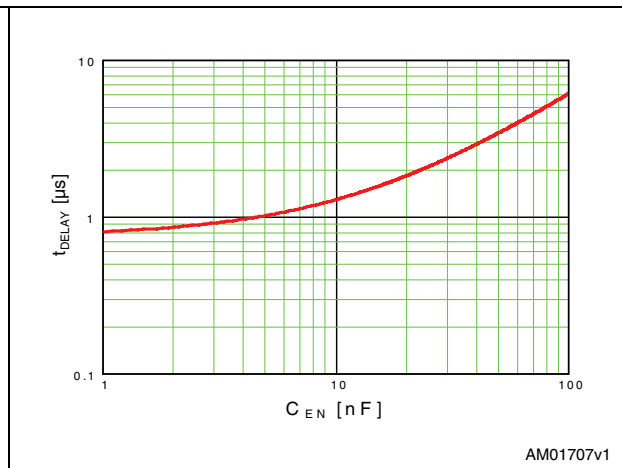

Figure 24. Typical delay time vs. C_{EN}



1.13 Power management

Even when operating at current levels well below the maximum ratings of the device, the operating junction temperature must be kept below 125 $^\circ C$.

Figure 25 on page 22 shows the IC's dissipated power versus the RMS load current in four different driving sequences, assuming the supply voltage is 24 V.

Figure 25. IC dissipated power versus output current

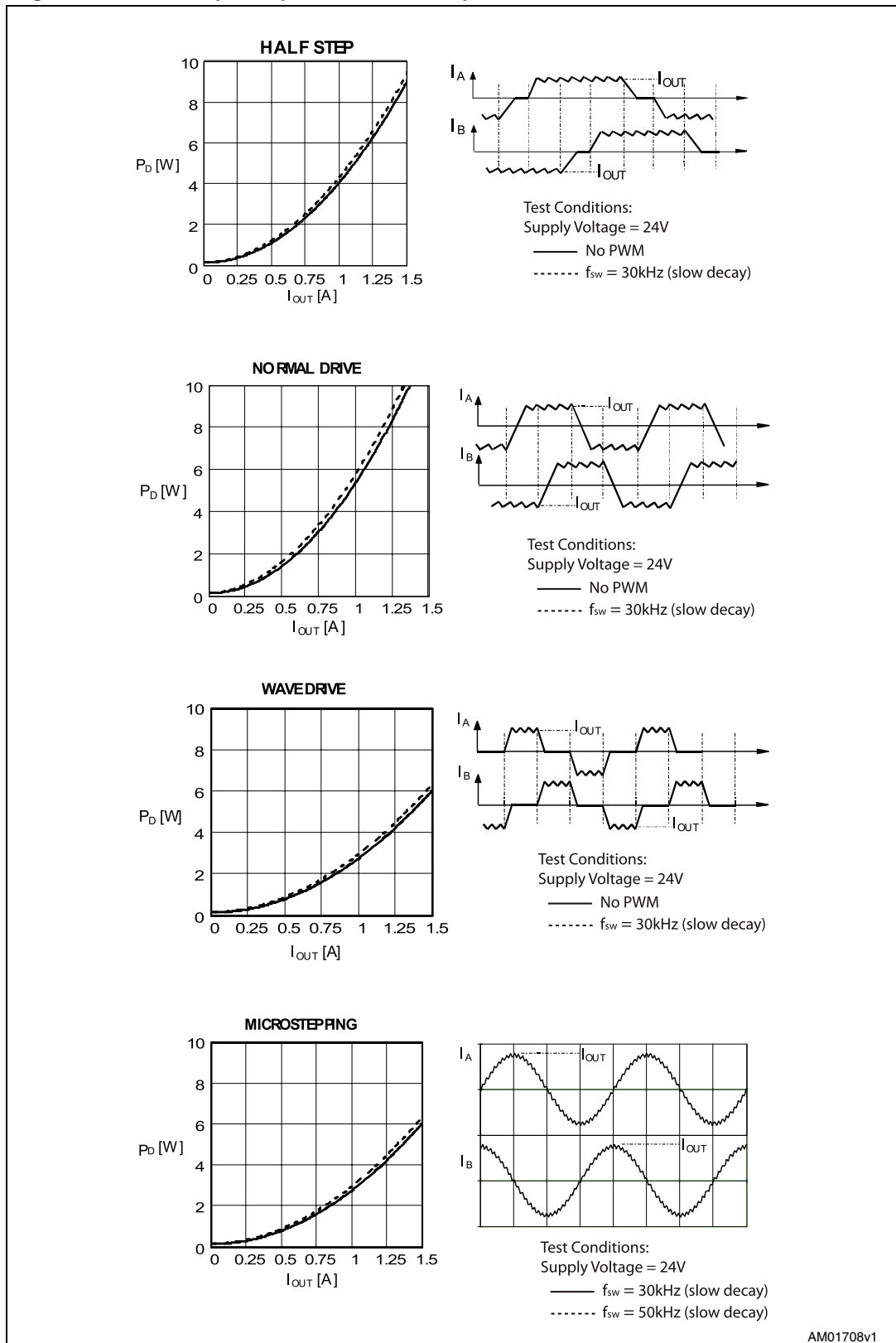

AM01708v1

1.13.1 Maximum output current versus selectable devices

Figure 26 shows a performance comparison between the L6228 (standard power) and the L6208 (high power) for different packages, with the following assumptions.

- Normal drive mode (two-phase on).
- Supply voltage: 24 V; switching frequency: 30 kHz.
- $T_{amb} = 25^{\circ}C$, $T_J = 125^{\circ}C$.
- Maximum $R_{DS(on)}$ (taking into account the process spread) considered, at $125^{\circ}C$.
- Maximum quiescent current I_Q (taking into account the process spread) considered.
- PCB is an FR4 with a dissipating copper surface on the top side of 6 cm^2 (with a thickness of $35\text{ }\mu\text{m}$) for SO and PowerDIP packages (D, N suffixes).
- PCB is an FR4 with a dissipating copper surface on the top side of 6 cm^2 (with a thickness of $35\text{ }\mu\text{m}$), 16 via holes and a ground layer for the PowerSO package (PD suffix).

For each device (on the x axis), the y axis reports the maximum output current.

Figure 26. Maximum output current vs. selectable devices

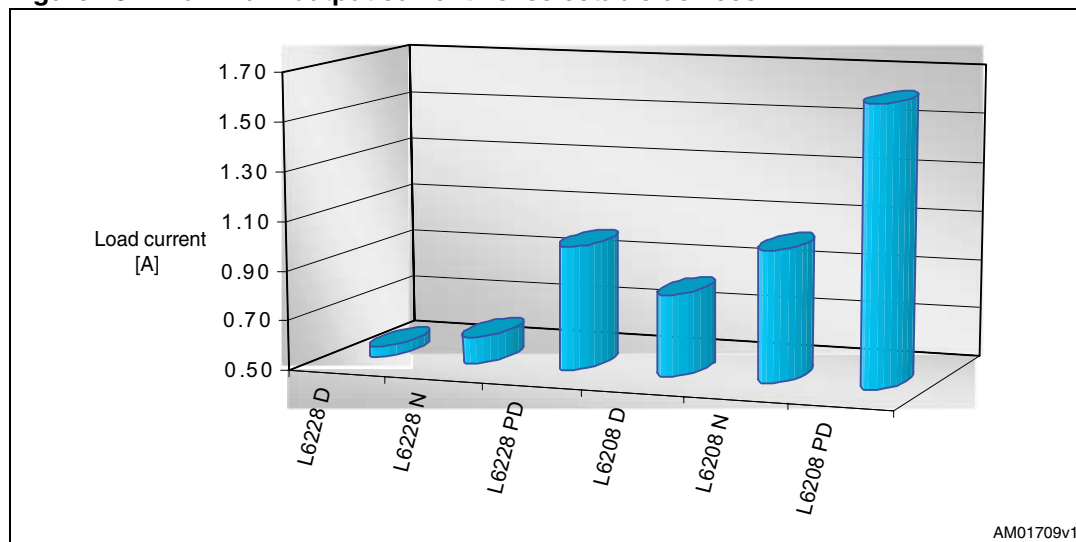

1.13.2 Power dissipation and thermal analysis with PractiSPIN™ software

The PractiSPIN™ software includes a power dissipation and thermal analysis section that helps to calculate the IC power dissipation and estimate its junction temperature through a simulation.

The purpose of this section is to help perform a quick evaluation of the device, package and dissipating copper area required by the user's application, and is a good starting point when designing an application (from the power dissipation and thermal points of view). Software results, especially thermal results, need to be confirmed on-bench.

The input data for simulation is divided in three sections.

- Application data: to select the motor characteristics and its configuration, the driving parameters and the analysis type (steady state, single pulse or repeated pulse analysis)
- Device data: to choose the device part number and edit some available IC parameters.
- PCB data: to select the package, PCB dissipating characteristics and ambient temperature

The output data includes the temperature and current profile waveforms, the estimated IC power dissipation and junction temperature.

For more details on the formulas used in the software, refer to the "Help" menu of the power dissipation and thermal analysis window.

Figure 27. Power dissipation and thermal analysis with PractiSPIN™ software

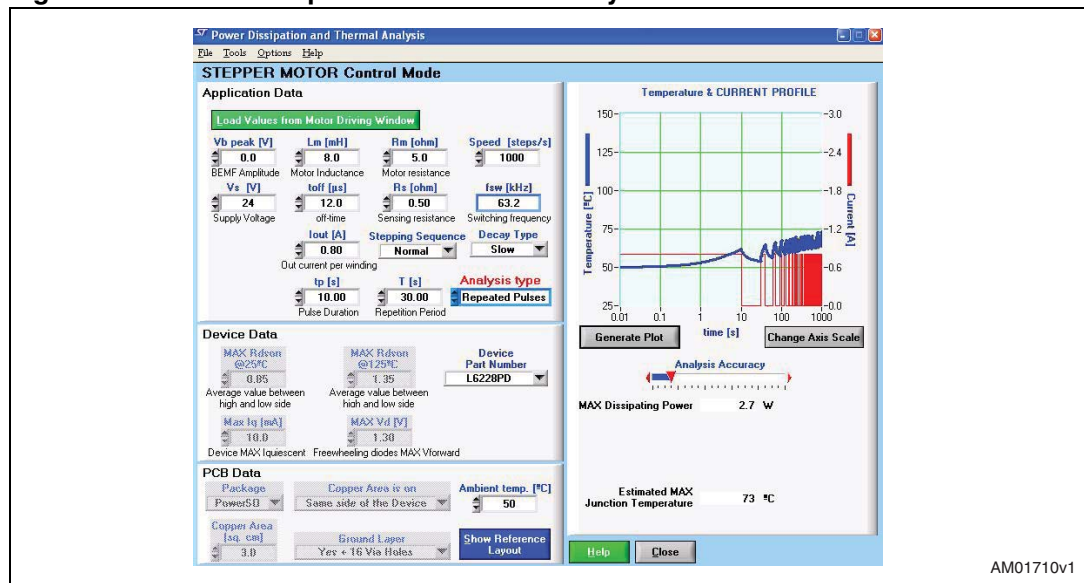

1.14 Choosing the decay mode

The L6228 can operate in either fast or slow decay mode, each having a specific recirculation path for the current during *off* time. In slow decay mode, only the lower DMOS is turned off and the current recirculates around the upper half of the bridge so that the voltage across the coil is close to zero. In fast decay mode, both DMOS's are turned off and the current recirculates back to the power supply rail so that the voltage across the coil is essentially the power supply voltage itself.

Slow decay operation provides several advantages: for a given peak current and *off* time, the current ripple is minimized. The same is true for acoustic noise and losses in the motor iron (achieving the same current ripple with fast decay mode would require a shorter *off* time resulting in a higher switching frequency and higher power dissipation in the IC). As current recirculates in the upper half of the bridge and both high-side DMOS's in the same bridge are on, synchronous rectification is realized, minimizing power dissipation in the power switches. Furthermore, since no output pin goes below GND (see [Section 1.2](#)), no power is dissipated on the sense resistor during the *off* time (see [Section 1.5](#)).

On the other hand, slow decay can be undesirable in some situations, for example when current has to be regulated at very low values or the motor winding L/R ratio is high. In these cases, an *on* time shorter than the minimum t_{ON} (about 1.5 μ s) may be requested to regulate the current, and this can cause the PWM controller to lose the regulation (refer to [Section 1.11](#)).

Another situation where fast decay should be preferred to slow decay is when the regulated current is expected to vary over time with a given profile (enforced, providing a variable voltage on the V_{ref} pins - see [Section 1.16](#)). Here fast decay helps to track fast decreasing edges in the desired profile.

1.15 Choosing the stepping sequence

The device can provide three different sequences to run a stepper motor: full-step, two-phase *on* (normal drive), full-step, one-phase *on* (wave drive) and half-step.

If half-step driving is used, the motor advances by half a step after each clock pulse, obtaining a higher position resolution and reducing instability due to low torque regions in certain motors' speed-torque diagrams, when used in full-step mode.

Figure 28. Torque instability in full-step mode.

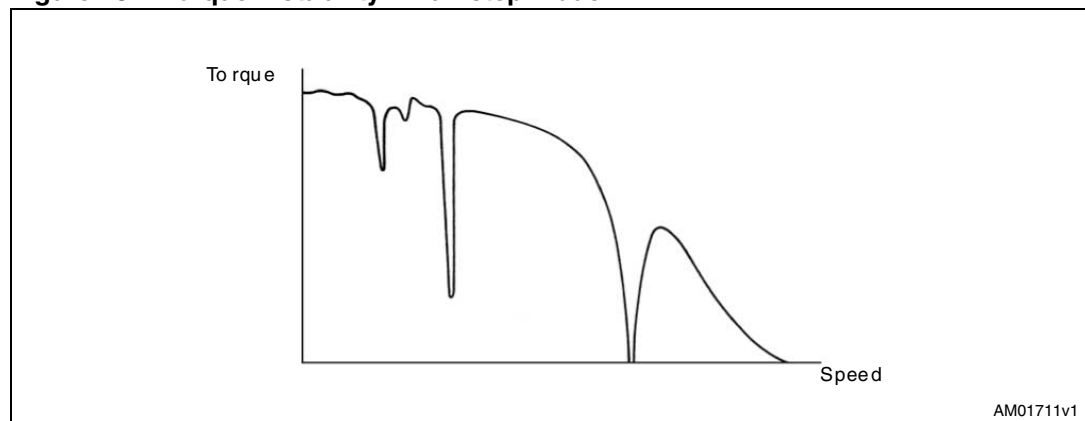

When this driving method is used, the torque is affected by ripple because in odd-numbered states, when both coils are driven, the total current in the motor windings is double that found in even-numbered states.

A way to avoid the high torque ripple in half-step mode is to supply the motor with a higher current (by a factor of $\sqrt{2}$) during the even-numbered states, in which only one winding is energized, simply by applying a $\sqrt{2}$ higher reference voltage at the V_{refA} , V_{refB} pins during these states (see [Figure 29 on page 26](#))^(b).

b. Also refer to [2] in [References](#).

Figure 29. Balanced half step for low torque ripple

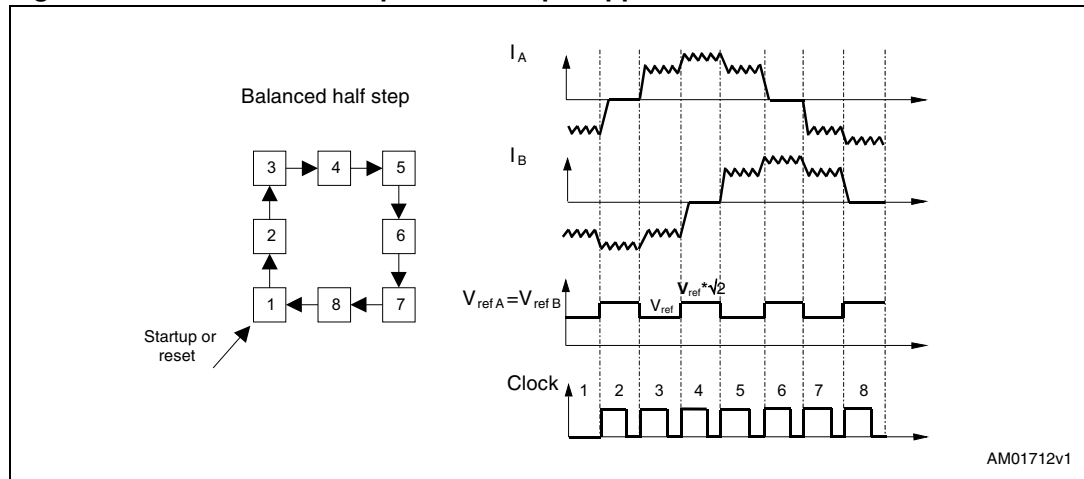

A simple circuit to generate two different reference voltages is shown in [Figure 30](#). R_1 and R_2 should be chosen to have:

Equation 18

$$V_{ref, HIGH} = V_{ref} \cdot \sqrt{2} = 5V \cdot \frac{R_2}{R_1 + R_2}$$

and R_3 should be:

Equation 19

$$R_3 = \frac{R_1 \cdot R_2}{(\sqrt{2} - 1) \cdot (R_1 + R_2)}$$

A similar circuit can also be used to modify the reference voltage in other situations. For example, it is possible at a constant rotation speed to reduce the motor torque and to increase it during acceleration and deceleration. A second transistor can be added to implement four different reference voltages, selectable by two logic signals.

Figure 30. Realizing half-step current shaping

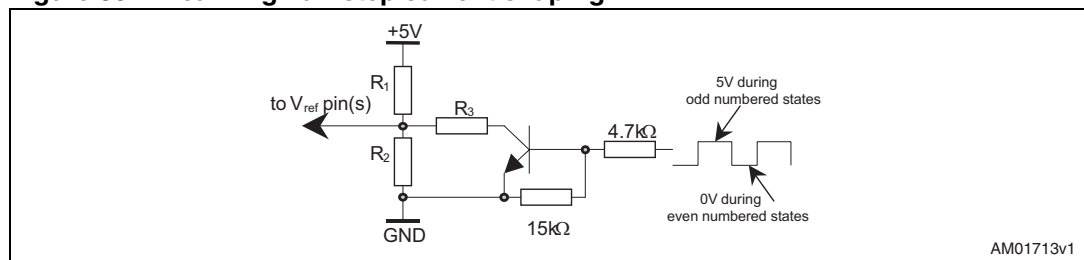

Normal and wave drive are full-step modes. In wave drive mode, the two motor windings are alternately energized, while in normal drive, both the windings are energized in each state, increasing the torque by a factor of $\sqrt{2}$. On the other hand, the total current in the motor is double, so the efficiency is similar. In wave drive mode, the torque ripple is higher than in normal drive mode.

1.16 Microstepping

Microstepping operation has several advantages, including the absence of any instability phenomena due to low torque regions in certain motors' speed-torque diagrams (see [Figure 28 on page 25](#)), reduction of mechanical noise and increased position resolution. The L6228 can be used as a two-phase microstepping driver IC^(c). The controller's circuitry allows for an easy and inexpensive design with such a device. By controlling the V_{ref} inputs, it is possible to obtain in the two phases variable output currents with a sine wave shape. A variable voltage proportional to the desired output current is applied to each reference pin. For microstepping, the two inputs are rectified sine-wave voltages with a phase delay of 90° . The L6228 is operated in the normal drive mode and the frequency of the two sine wave voltages must be 1/4 of the CLOCK frequency. [Figure 31](#) shows a circuit to generate the two sine wave voltages using low-pass filters and two PWM outputs of a μC (see [Section 1.8](#)). [Figure 32](#) shows the V_{ref} voltages, the CLOCK signal and the output currents.

Figure 31. Microstepping application

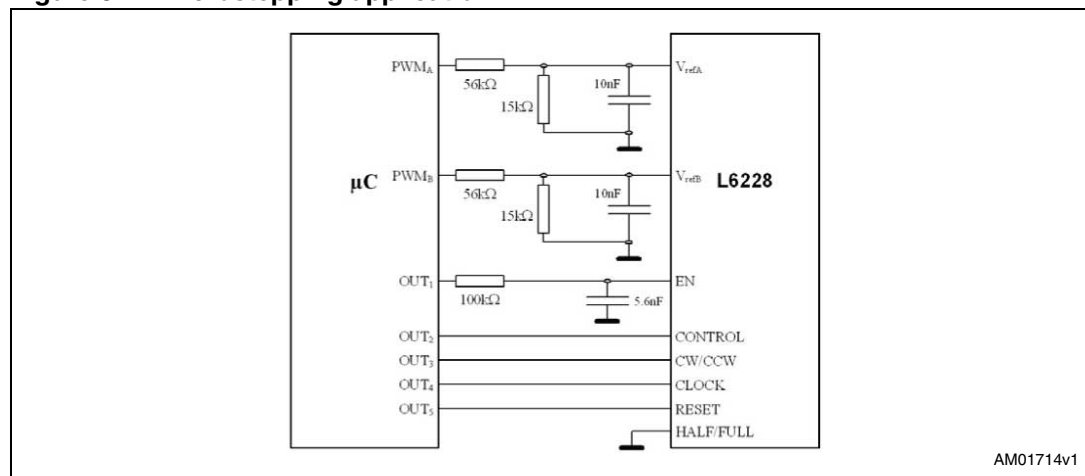

AM01714v1

Figure 32. Microstepping reference voltages, output currents and CLOCK signal

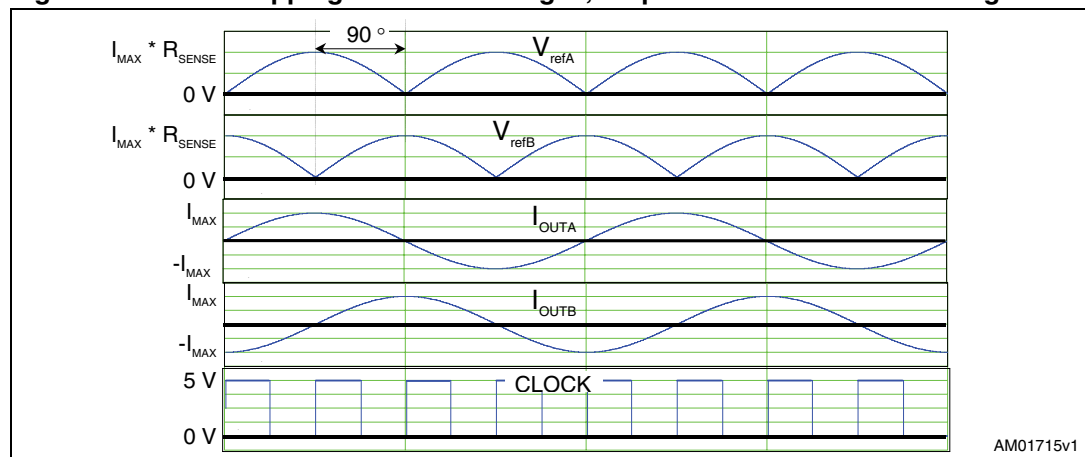

AM01715v1

The slow decay mode can sometimes be inadequate, particularly at high rotation speeds, since it does not allow the motor current to decay quickly enough and follow the decreasing

c. Refer to [5] in [References](#).

slope of the desired sine wave. In cases like this, the fast decay mode can just be applied during the negative slope of the current (*Figure 33*).

The disadvantage is an increased current ripple in the other winding (where the current is increasing and fast decay is not needed).

Figure 33. Using fast decay during a high, negative current slope

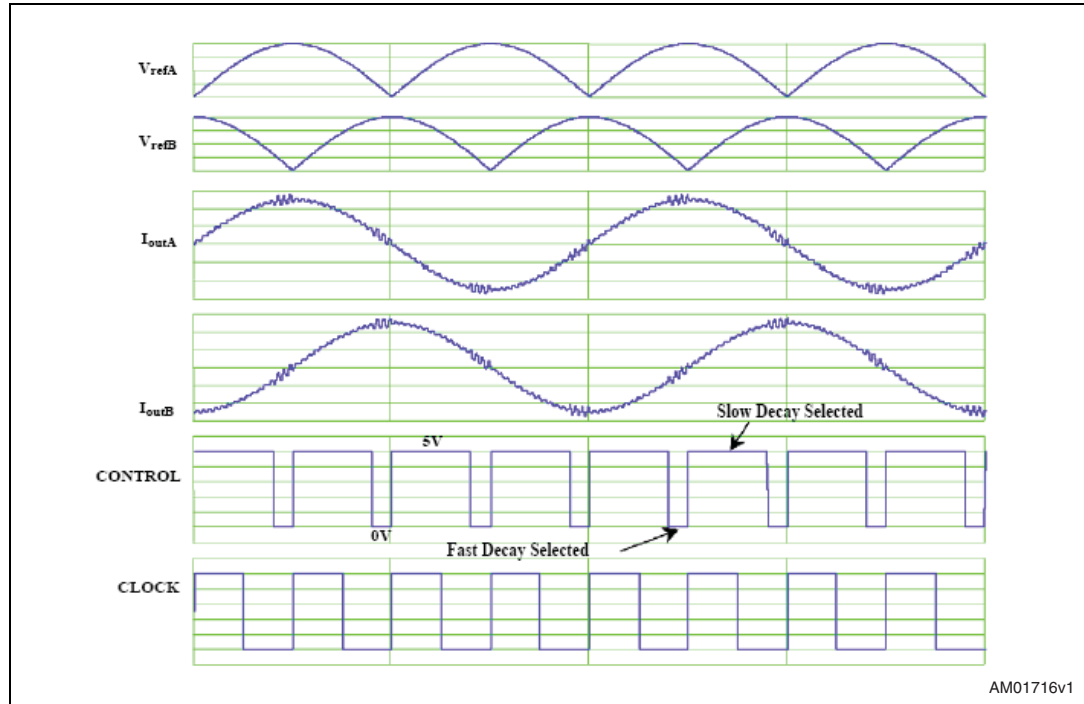

2 Application example

Table 2. Application data

Application data	Value
Rotation speed	300 rpm ($f_{CK} = 1$ kHz)
Winding peak current	1 A
Maximum ripple	50 mA
Supply voltage	24 V \pm 5%
Sequence	Wave mode

Table 3. Motor data

Motor data	Value
Winding resistance	6.6 Ω
Winding inductance	7.9 mH
Step angle	1.8°/step
Maximum BEMF at 300 rpm	15 V

The first step is to select the type of decay. For the purpose of this example, we will implement slow decay, which allows a lower power dissipation, lower ripple and avoids voltages below GND at the output pins during recirculation.

The power dissipation and thermal analysis PractiSPIN™ tool allow calculation of the IC power dissipation and estimation of the junction temperature. The purpose of this section is to help perform a fast evaluation of the device, package and dissipating copper area required by the user's application, and is intended as a good starting point when designing an application (from the power dissipation and thermal points of view). Software results, especially thermal results, need to be confirmed on-bench.

The bulk capacitor needs to withstand at least $24\text{ V} + 5\% + 25\% \cong 32\text{ V}$. A 50 V capacitor will be used. Allowing a voltage ripple of 200 mV, the capacitor's ESR should be lower than $200\text{ mV}/0.5\text{ A} = 400\text{ m}\Omega$; the AC current capability should be about 0.5 A.

Providing a reference voltage of 0.5 V, 1- Ω sensing resistors are needed. In slow decay mode, the resistors' power rating is approximately $P_R \cong I_{rms}^2 \cdot R_{SENSE} \cdot D \cong 0.25\text{ W}$. A 1 Ω - 0.25 W - 1% resistor is used. The charge pump uses recommended components (1N4148 diodes, ceramic capacitors and a 100 Ω resistor to reduce EMI).

$R = 18\text{ k}\Omega$, $C = 1.2\text{ nF}$ are connected to the RC pins, obtaining $t_{OFF} \cong 16\text{ }\mu\text{s}$. A 5.6 nF capacitor has been placed on the EN pin, and the pin is driven by the μC through a 100-k Ω resistor. With these values, if there is a short-circuit between two OUT pins or an OUT pin and GND, the power DMOS's turn off after approximately 1 μs , and $t_{DISABLE} \cong 240\text{ }\mu\text{s}$.

Figure 34. Application example

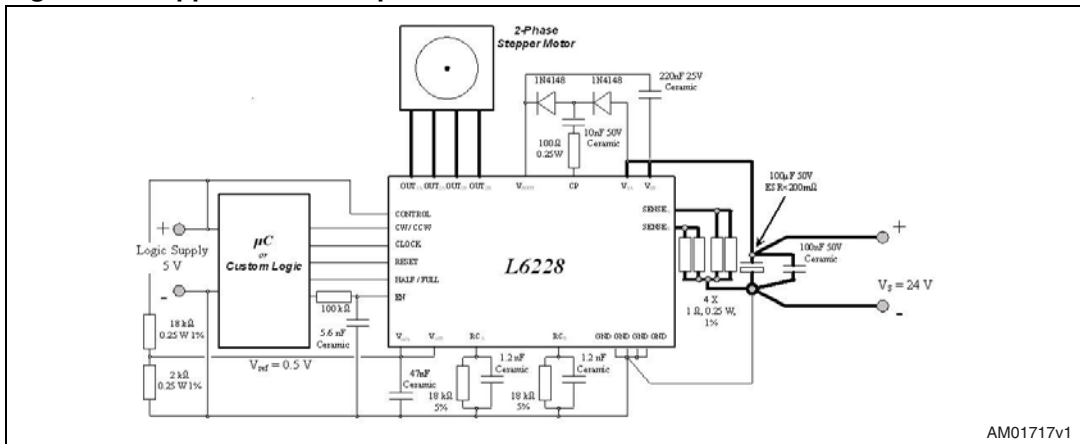

With wave drive selected, the dissipating power is about 0.8 W. If the ambient temperature is lower than 50° C, with a 4 cm² copper area on the PCB and an SO24 package, the estimated junction temperature is about 94° C. Using more copper area or a PowerDIP package will reduce the junction temperature.

Appendix A Demonstration board

A.1 PractiSPIN™

PractiSPIN™ is an evaluation and demonstration system that can be used with the powerSPIN™ family (L62xx) of devices. A graphical user interface (GUI) program (shown in [Figure 35](#)) runs on an IBM PC under Windows and communicates with a common ST7-based interface board ([Figure 36 on page 32](#)) through the RS-232 serial port. The ST7 interface board connects to a device-specific demonstration board (target board) via a standard 34-pin ribbon cable interface.

Depending on the target device, the PractiSPIN™ can drive a stepper motor, 1 or 2 DC motors or a brushless DC (BLDC) motor, operating significant parameters such as speed, current, voltage, direction, acceleration and deceleration rates from a user-friendly graphic interface, and programming a sequence of movements.

The software can also evaluate the power dissipated by the selected device and, for a given package and dissipating copper area on the PCB, estimate the device's junction temperature.

Figure 35. PractiSPIN™ PC software

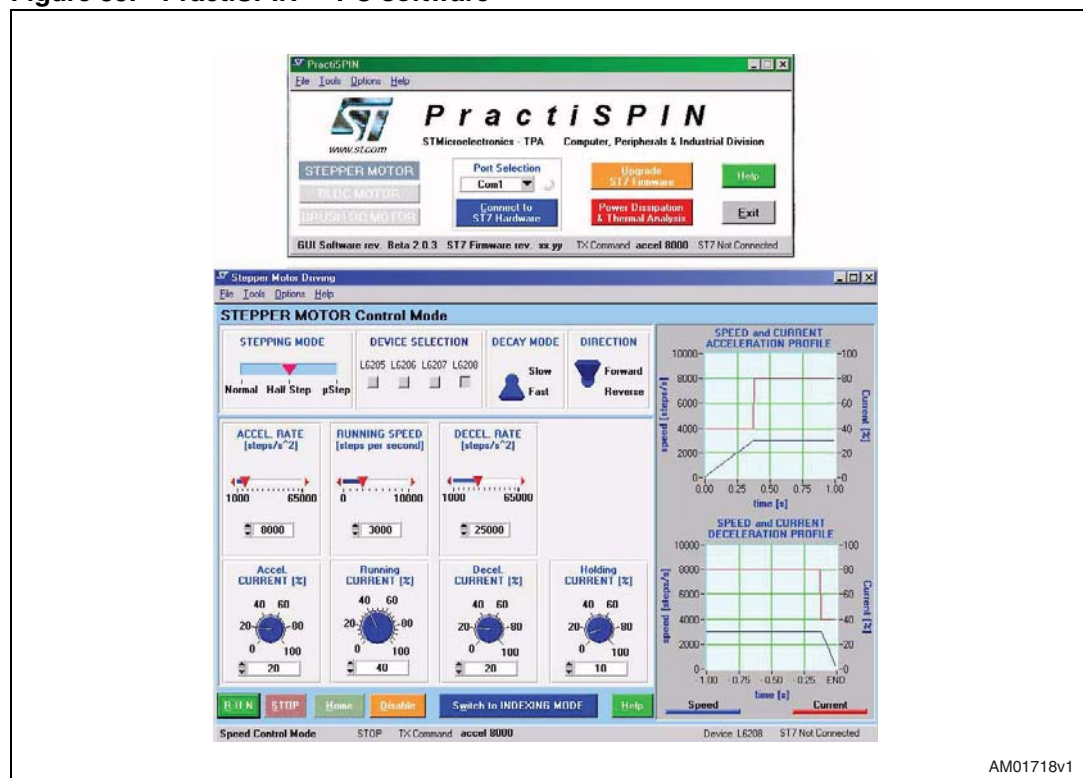

AM01718v1

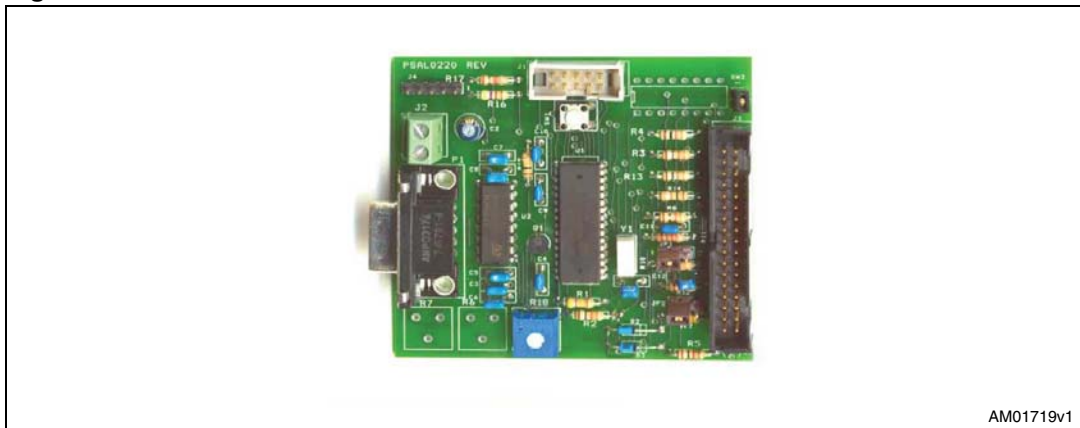
Figure 36. PractiSPIN™ ST7 demonstration board

A.2 L6228N evaluation with EVAL6208N

To easily evaluate the device in PowerDIP packages, it is possible to use the EVAL6208N, replacing the device directly on the available socket.

We recommend changing the sense resistor values to manage lower load currents according to the device's specifications.

The EVAL6208N's electrical schematic is shown in [Figure 37 on page 33](#). For more information, refer to AN1451 "L6208 fully-integrated two-phase stepper motor driver".

A.2.1 Important notes

- JP1: should be closed in the INT position for use with the PractiSPIN™ ST7 board.
- C6: recommended change to 5.6 nF for safe overcurrent protection.
- R8: recommended change to 100 kΩ for safe overcurrent protection.
- R9: recommended change to 100 kΩ if EN pin is driven from the CN5 connector (for example with PractiSPIN™ ST7 board) for safe overcurrent protection.
- R20, R24: set the maximum current obtainable through PractiSPIN™ (see PractiSPIN™ documentation).
- R2: recommended change to adequate value (depending on supply voltage) to obtain 5 V across D3.

Figure 37. EVAL6208N electrical schematic

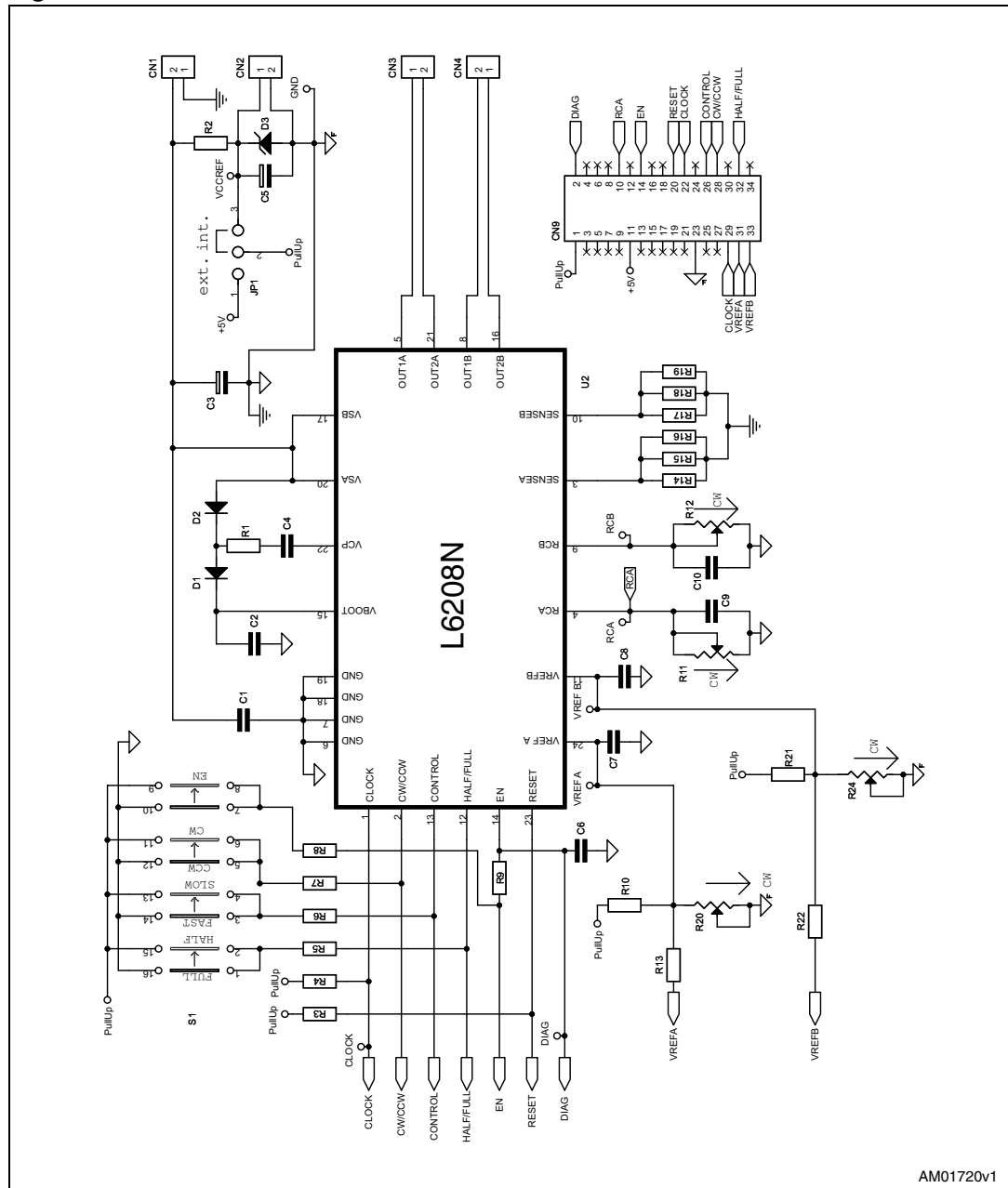

A.3 EVAL6228QR

A demonstration board has been designed to help in the evaluation of the device in QFN packages. The board implements a typical application that can be used as a reference design to drive a two-phase bipolar stepper motor with currents up to 1 A DC.

Thanks to the L6228Q's small footprint (QFN 5 x 5 mm 32 leads), the PCB is very compact (27 x 32 mm).

Figure 42 on page 37 shows the electrical schematic of the board. Table 4 reports the parts list.

Table 4. EVAL6228QR parts list

Part reference	Part value	Part description
C1	220 nF/25 V	Capacitor
C2	220 nF/63 V	Capacitor
C3	100 µF/63 V	Capacitor
C4	10 nF/25 V	Capacitor
C5	5.6 nF	Capacitor
C6, C6	820 pF	Capacitor
C8, C9	220 nF	Capacitor
D1	BAT46SW	Diodes
R1, R2, R3, R4, R5, R8	100 kΩ 5% 0.25 W	Resistor
R6, R7	100kΩ 1% 0.25 W	Resistor
R9, R10	0.4 Ω 1 W	Resistor
R11, R13	20 kΩ 1% 0.25 W	Resistor
R12, R14	2 kΩ 1% 0.25 W	Resistor
U1	L6228Q	Stepper motor driver in VFQFPN5x5

Figure 38. EVAL6228QR

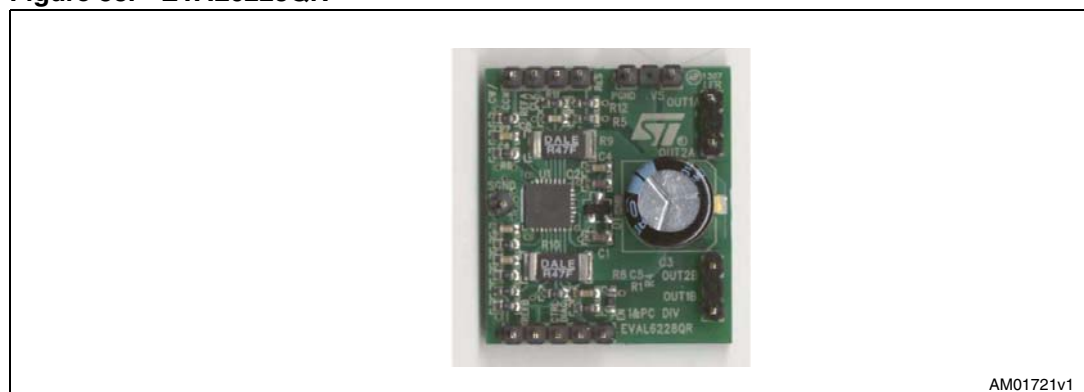

AM01721v1

A *step* clock input is used to apply a clock signal that determines the progress of the internal state machine. It can be reset to its initial state by pulling down the reset line.

To perform the PWM current control, an analog reference voltage should be provided to each of the driver's channels. A fixed reference voltage can be easily obtained through a

resistive divider from an external voltage rail and GND (possibly the one supplying the μC or the rest of the application).

Otherwise, a very simple way to obtain a variable voltage without using a DAC is to low-pass filter a PWM output of a μC .

The input lines CW/CCW, control, half/full, EN and reset are connected to ground through a pull-down resistor which sets as default the low logic level on these lines. An external signal can be applied to change each input status.

D1, C1 and C4 make up a charge-pump circuit, which generates the supply voltage for the high-side integrated MOSFETs. Due to voltage and current switching at relatively high frequencies, these components are connected together through short paths in order to minimize induced noise on other circuitries.

R1 and C5 are used by the overcurrent protection's integrated circuitry (the disable time t_{DISABLE} is about 200 μs and delay time t_{DELAY} about 1 μs with the values in [Table 4](#)).

R6, C6 and R7, C7 are used to set the *off* time t_{OFF} of the two PWM channels at about 50 μs . The *off* time should be adjusted according to the motor's electrical characteristics and supply voltage by changing the R6, C6 and R7, C7 values.

R11, R12, C8 and R13, R14, C9 are low-pass filters used to provide an external reference voltage through a PWM output of a μC .

[Figure 39](#) and [Figure 41](#) show the components' placement and the two layers of the EVAL6228QR reference design board. A GND area has been used to improve the IC's power dissipation.

Figure 39. EVAL6228QR component placement

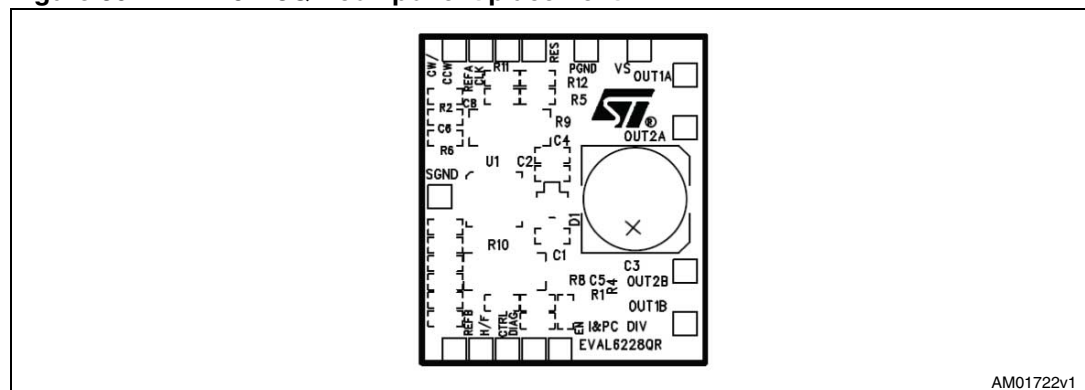

Figure 40. EVAL6228QR top layer

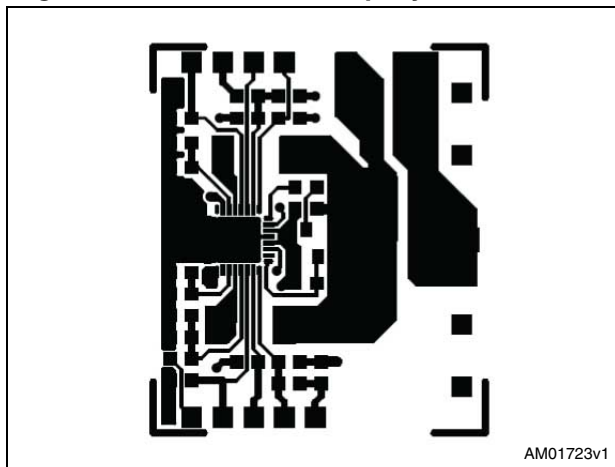

Figure 41. EVAL6228QR bottom layer

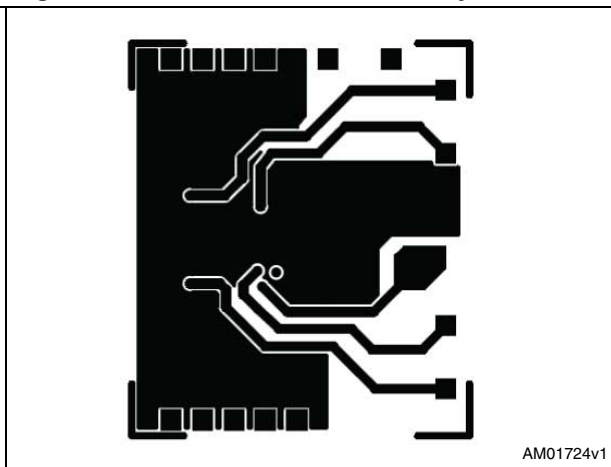
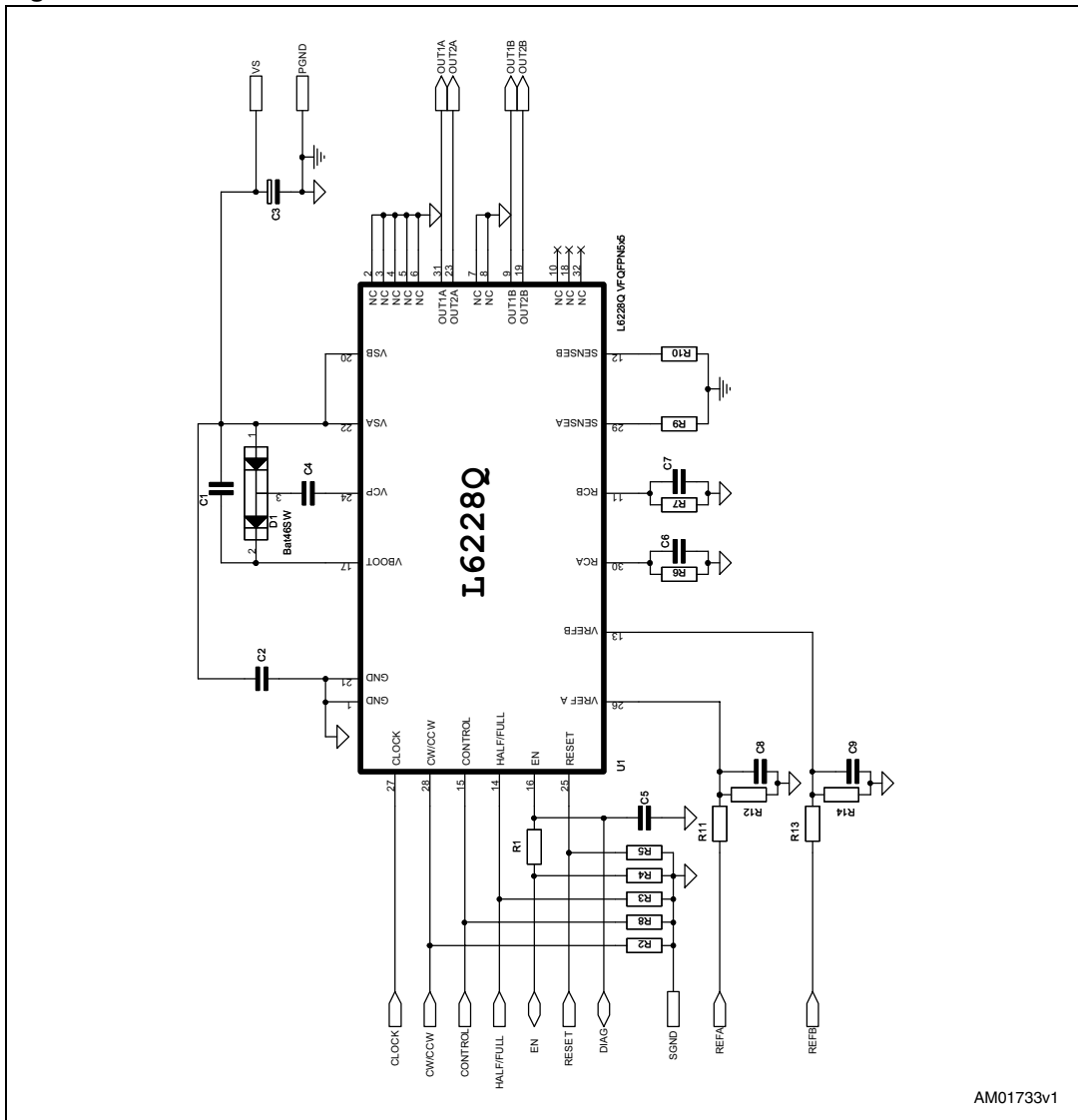

Figure 42. EVAL6228QR electrical schematic



References

1. "A New Fully Integrated Stepper Motor Driver IC", Proceedings of PCIM 2001, September 2001, Intertech Communication.
2. "Stepper Motor Driving" (AN235).
3. "Controlling Voltage Transients in Full Bridge Driver Applications" (AN280).
4. "Stepper Motor Drive Considerations, Common Problems and Solutions" (AN460).
5. "Microstepping Stepper Motor Drive Using Peak Detecting Current Control" (AN1495).
6. "A New High Power IC Surface Mount Package Family" (AN668).

Revision history

Table 5. Document revision history

Date	Revision	Changes
22-Sep-2009	1	Initial release.

Please Read Carefully:

Information in this document is provided solely in connection with ST products. STMicroelectronics NV and its subsidiaries ("ST") reserve the right to make changes, corrections, modifications or improvements, to this document, and the products and services described herein at any time, without notice.

All ST products are sold pursuant to ST's terms and conditions of sale.

Purchasers are solely responsible for the choice, selection and use of the ST products and services described herein, and ST assumes no liability whatsoever relating to the choice, selection or use of the ST products and services described herein.

No license, express or implied, by estoppel or otherwise, to any intellectual property rights is granted under this document. If any part of this document refers to any third party products or services it shall not be deemed a license grant by ST for the use of such third party products or services, or any intellectual property contained therein or considered as a warranty covering the use in any manner whatsoever of such third party products or services or any intellectual property contained therein.

UNLESS OTHERWISE SET FORTH IN ST'S TERMS AND CONDITIONS OF SALE ST DISCLAIMS ANY EXPRESS OR IMPLIED WARRANTY WITH RESPECT TO THE USE AND/OR SALE OF ST PRODUCTS INCLUDING WITHOUT LIMITATION IMPLIED WARRANTIES OF MERCHANTABILITY, FITNESS FOR A PARTICULAR PURPOSE (AND THEIR EQUIVALENTS UNDER THE LAWS OF ANY JURISDICTION), OR INFRINGEMENT OF ANY PATENT, COPYRIGHT OR OTHER INTELLECTUAL PROPERTY RIGHT.

UNLESS EXPRESSLY APPROVED IN WRITING BY AN AUTHORIZED ST REPRESENTATIVE, ST PRODUCTS ARE NOT RECOMMENDED, AUTHORIZED OR WARRANTED FOR USE IN MILITARY, AIR CRAFT, SPACE, LIFE SAVING, OR LIFE SUSTAINING APPLICATIONS, NOR IN PRODUCTS OR SYSTEMS WHERE FAILURE OR MALFUNCTION MAY RESULT IN PERSONAL INJURY, DEATH, OR SEVERE PROPERTY OR ENVIRONMENTAL DAMAGE. ST PRODUCTS WHICH ARE NOT SPECIFIED AS "AUTOMOTIVE GRADE" MAY ONLY BE USED IN AUTOMOTIVE APPLICATIONS AT USER'S OWN RISK.

Resale of ST products with provisions different from the statements and/or technical features set forth in this document shall immediately void any warranty granted by ST for the ST product or service described herein and shall not create or extend in any manner whatsoever, any liability of ST.

ST and the ST logo are trademarks or registered trademarks of ST in various countries.

Information in this document supersedes and replaces all information previously supplied.

The ST logo is a registered trademark of STMicroelectronics. All other names are the property of their respective owners.

© 2009 STMicroelectronics - All rights reserved

STMicroelectronics group of companies

Australia - Belgium - Brazil - Canada - China - Czech Republic - Finland - France - Germany - Hong Kong - India - Israel - Italy - Japan - Malaysia - Malta - Morocco - Philippines - Singapore - Spain - Sweden - Switzerland - United Kingdom - United States of America

www.st.com

Mouser Electronics

Authorized Distributor

Click to View Pricing, Inventory, Delivery & Lifecycle Information:

[STMicroelectronics:](#)

[EVAL6208N](#)