

## Electronic housing - UEGM 25 - 2792015

Please be informed that the data shown in this PDF Document is generated from our Online Catalog. Please find the complete data in the user's documentation. Our General Terms of Use for Downloads are valid (<http://phoenixcontact.com/download>)



Electronic housing, for PCB insertion, fully equipped with 3 screw or 6 tab connections per side

The figure shows version UEGM 22.5

### Your advantages

- ✓ Cost-effective series production, since the base element and the assembled PCB are soldered by machine
- ✓ Efficient assembly thanks to overlapping housing parts
- ✓ Complex electronic circuits can be integrated, with up to 24 connections on two levels
- ✓ Can be snapped onto standard NS 35/7,5 and NS 35/15 DIN rails



### Key Commercial Data

Packing unit	10 pc
GTIN	 4 017918 072520
GTIN	4017918072520

### Technical data

#### General

Housing type	Complete housing
Housing material	Polyamide (PA 6.6)
Color (RAL)	green

#### Ambient conditions

Ambient temperature (operation)	-40 °C ... 105 °C
---------------------------------	-------------------

#### Dimensions

Length	79 mm
Height	85.5 mm
Width	25 mm
Pitch	5 mm

# Electronic housing - UEGM 25 - 2792015

## Technical data

### Dimensions

Depth	79 mm
-------	-------

### Technical data

Connection in acc. with standard	CUL
Nominal voltage $U_N$	300 V
Nominal current $I_N$	10 A
AWG/kcmil	30-12
Indicator1	CUL1
Power dissipation without gap	4 W
Power dissipation with 20 mm gap	10 W
Number of positions	6

### Connection data

Conductor cross section solid min.	0.2 mm <sup>2</sup>
Conductor cross section solid max.	4 mm <sup>2</sup>
Conductor cross section flexible min.	0.2 mm <sup>2</sup>
Conductor cross section flexible max.	2.5 mm <sup>2</sup>
Conductor cross section AWG min.	24
Conductor cross section AWG max.	12
Stripping length	8 mm

### Standards and Regulations

Connection in acc. with standard	CUL
Flammability rating according to UL 94	V2

### Environmental Product Compliance

REACH SVHC	Lead 7439-92-1
China RoHS	Environmentally Friendly Use Period = 50
	For details about hazardous substances go to tab "Downloads", Category "Manufacturer's declaration"

## Drawings

# Electronic housing - UEGM 25 - 2792015

Explosion drawing

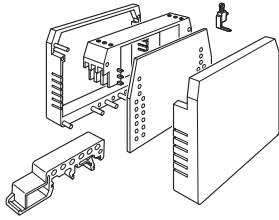

Dimensional drawing

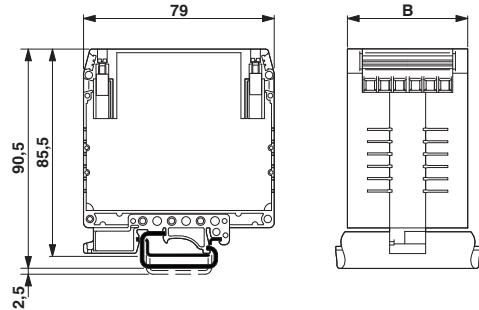

Dimensional drawing

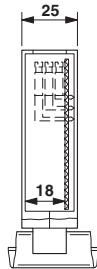

Dimensional drawing

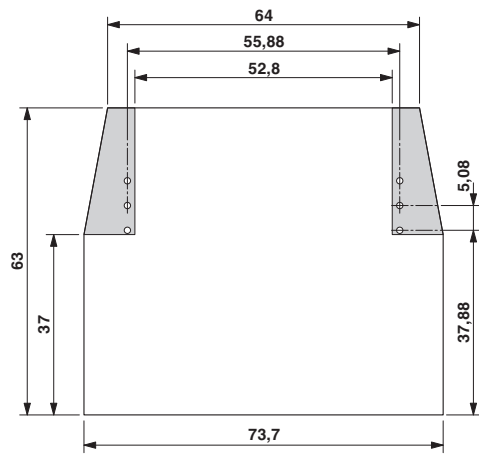

UEGM 25... und UEGM 27,5-SMD with 1 PCB, 6 positions or 12 positions (FS/FS)

Schematic diagram

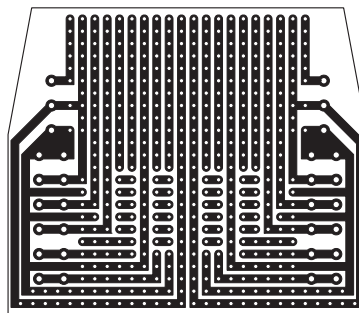

Approvals

Approvals

Approvals

UL Recognized / EAC / cULus Recognized

# Electronic housing - UEGM 25 - 2792015

## Approvals

Ex Approvals

### Approval details

UL Recognized		<a href="http://database.ul.com/cgi-bin/XYV/template/LISEXT/1FRAME/index.htm">http://database.ul.com/cgi-bin/XYV/template/LISEXT/1FRAME/index.htm</a>	FILE E 240868
---------------	---	---	---------------

EAC			B.01742
-----	---	--	---------

cULus Recognized		<a href="http://database.ul.com/cgi-bin/XYV/template/LISEXT/1FRAME/index.htm">http://database.ul.com/cgi-bin/XYV/template/LISEXT/1FRAME/index.htm</a>	E60425-19770427
------------------	--	---	-----------------

Nominal voltage UN	300 V
Nominal current IN	10 A
mm <sup>2</sup> /AWG/kcmil	30-12

Phoenix Contact 2018 © - all rights reserved  
<http://www.phoenixcontact.com>

PHOENIX CONTACT GmbH & Co. KG  
Flachsmarktstr. 8  
32825 Blomberg  
Germany  
Tel. +49 5235 300  
Fax +49 5235 3 41200  
<http://www.phoenixcontact.com>

# Mouser Electronics

Authorized Distributor

Click to View Pricing, Inventory, Delivery & Lifecycle Information:

[Phoenix Contact:](#)

[2792015](#)