

THIS DOCUMENT IS THE PROPERTY OF KEYSTONE ELECTRONICS CORP. AND SHALL NOT BE REPRODUCED, DISTRIBUTED OR USED AS A BASIS FOR MANUFACTURE WITHOUT PRIOR WRITTEN PERMISSION FROM KEYSTONE ELECTRONICS CORP.

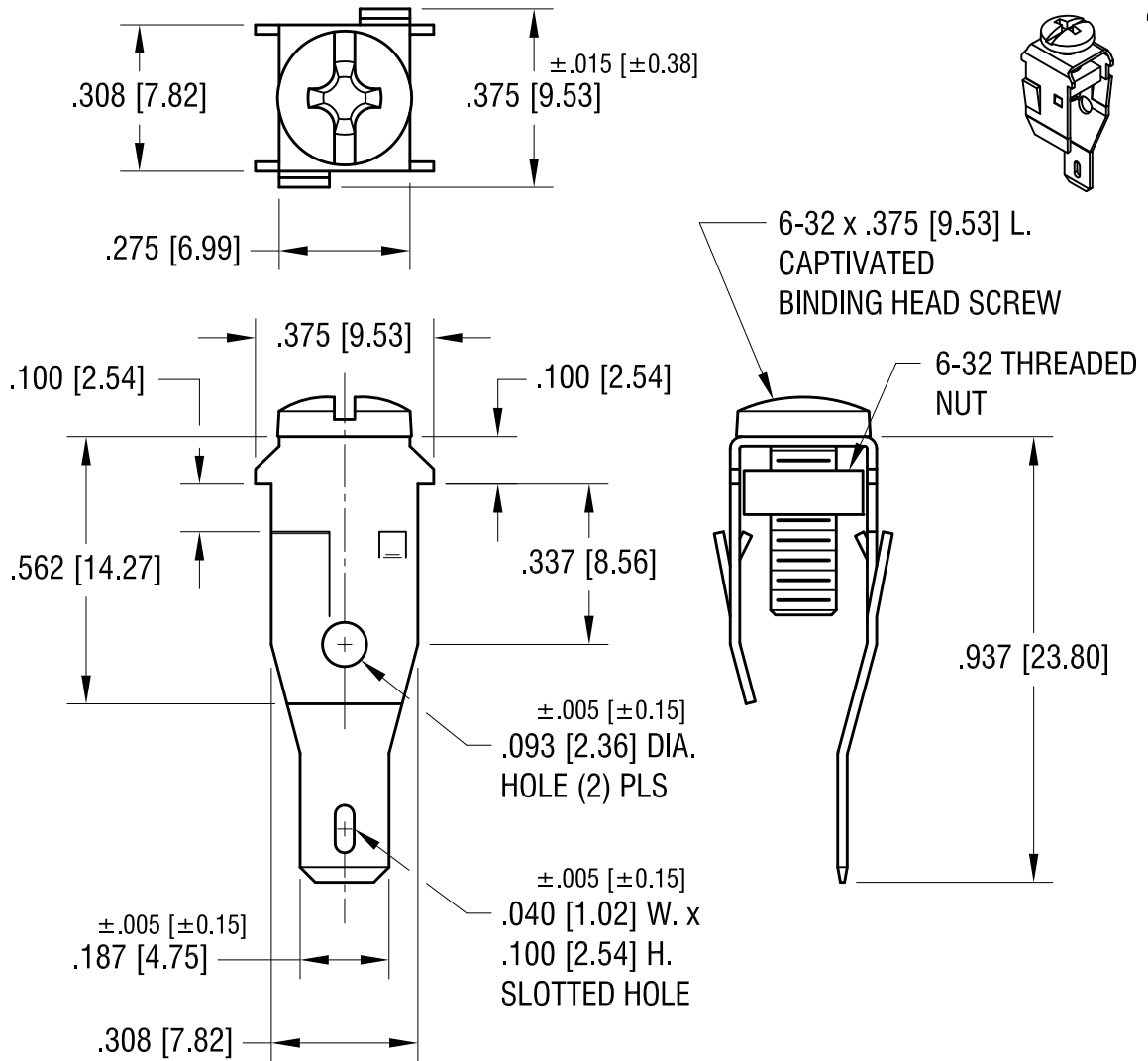

NOTE:

- HEAT TREAT TO SPRING TEMPER
- TERMINAL: MAT'L: .020 [0.50] TH'K STEEL
FINISH: MATTE TIN PLATE
SCREW/NUT: MAT'L: STEEL
FINISH: ZINC PLATE
- PRESS-FIT INTO .312 [7.92] SQ. HOLE

DATE	DESCRIPTION	REV.
7.16.09	CHANGE AS PER ECN 09-106	C
4.17.96	CHANGE PER ECR 96-021	B
2.26.93	REVISED	A

KEYSTONE ELECTRONICS CORP.			
www.keyelco.com • ASTORIA, N.Y. 11105-2017 • Tel (718) 956-8900			
PART NAME		PRESS-FIT SCREW TERMINAL	
MATERIAL		AS NOTED	
FINISH		DRN BY	DATE
AS NOTED		BOONE	5.7.82
		APP'D	SCALE
		LN	2.5X
TOLERANCES	INCH [MM]	CODE	DWG NO.
DECIMAL	$\pm .010 [\pm 0.25]$	C	1273
ANGULAR	$\pm 1^\circ$		
UNLESS OTHERWISE SPECIFIED			

Mouser Electronics

Authorized Distributor

Click to View Pricing, Inventory, Delivery & Lifecycle Information:

[Keystone Electronics:](#)

[1273](#)