

10	9	8	7	6	5	4	3	2	1
MATERIAL NUMBER	ENG. NUMBER	TAPE MATERIAL NUMBER	TAPE ENG NUMBER	WIRE SIZE AWG	WIRE SIZE MM SQ.	NYLON COLOR	B MAX.	D MWID	E MIN. DIA.
191640075	SC-9280	N/A	N/A	12-10	4.0-6.0	YELLOW	.46/11.7	.23/5.8	.148/3.76

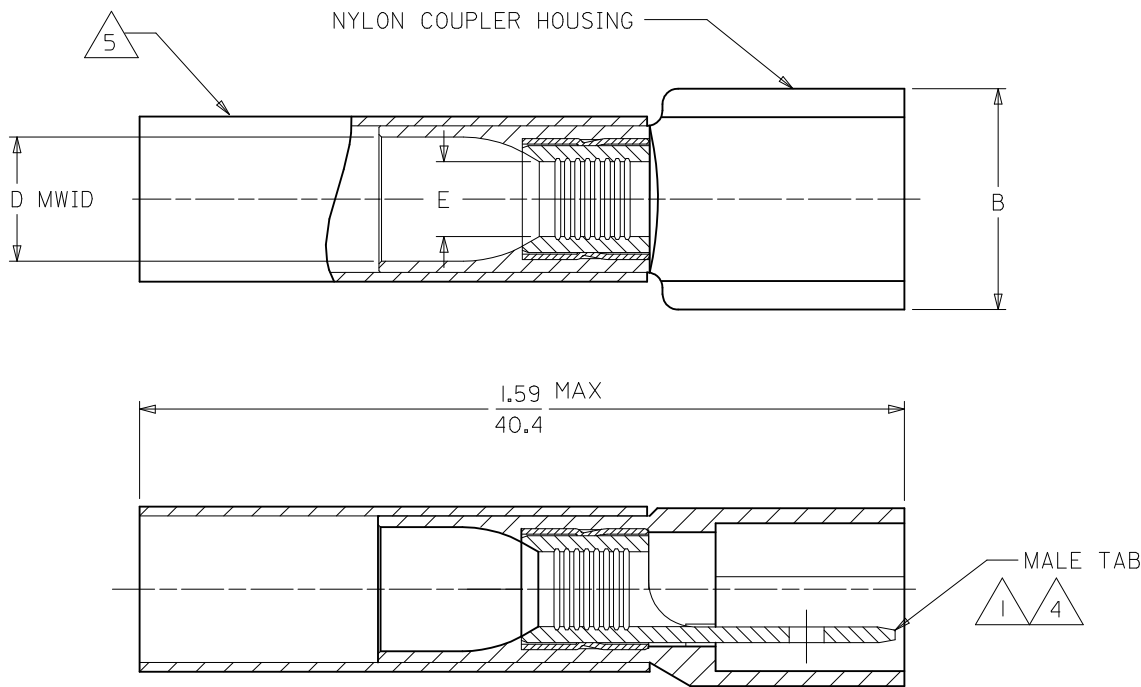

NOTES:

- 1. MALE TAB CONFORMS TO UL310.
- 2. ALL DIMENSIONS SHOWN ARE BEFORE SHRINK TUBING IS HEATED.
- 3. "MWID" DENOTES MAX. WIRE INSULATION DIA.
- 4. TAB MATERIAL: COPPER ALLOY, PLATING: TIN
- 5. NYLON HEAT SHRINKABLE TUBING WITH HOTMELT INNER LINER. SEE CHART FOR COLOR.
- 6. ALL PARTS ARE ROHS COMPLIANT.

SALES DRAWING

DELETE PART #S EC NO: PG2018-0080 G DRAWING: GRO/JAS01 2017/08/02 CHKD: JMACNEIL 2017/08/02 APPR: JMACNEIL 2017/08/23 REV DESCRIPTION	QUALITY SYMBOLS	GENERAL TOLERANCES (UNLESS SPECIFIED)	DIMENSION STYLE	SCALE	DESIGN UNITS	THIRD ANGLE PROJECTION	
	▼=0 ▽=0	mm INCH 4 PLACES ± --- ± --- 3 PLACES ± --- ± --- 2 PLACES ± --- ± --- 1 PLACE ± --- ± --- ANGULAR ± ---°	IN/MM	---	INCH	DRAWN BY DATE BRE 2002/10/25 CHECKED BY DATE HEB 2002/10/25 APPROVED BY DATE RWD 2002/10/25	TITLE PERMA-SEAL COUPLER MALE TAB TERMINAL 12-10 AWG
	DRAFT WHERE APPLICABLE MUST REMAIN WITHIN DIMENSIONS	SEE CHART	MATERIAL NO.	DOCUMENT NO.	SHEET NO.	MOLEX INCORPORATED SD-19164-039 1 OF 1	
	THIS DRAWING CONTAINS INFORMATION THAT IS PROPRIETARY TO MOLEX INCORPORATED AND SHOULD NOT BE USED WITHOUT WRITTEN PERMISSION						

10	9	8	7	6	5	4	3	2	1
MATERIAL NUMBER	ENG. NUMBER	TAPE MATERIAL NUMBER	TAPE ENG NUMBER	WIRE SIZE AWG	WIRE SIZE MM SQ.	NYLON COLOR	B MAX.	D MWID	E MIN. DIA.
191640075	SC-9280	N/A	N/A	12-10	4.0-6.0	YELLOW	.46/11.7	.23/5.8	.148/3.76

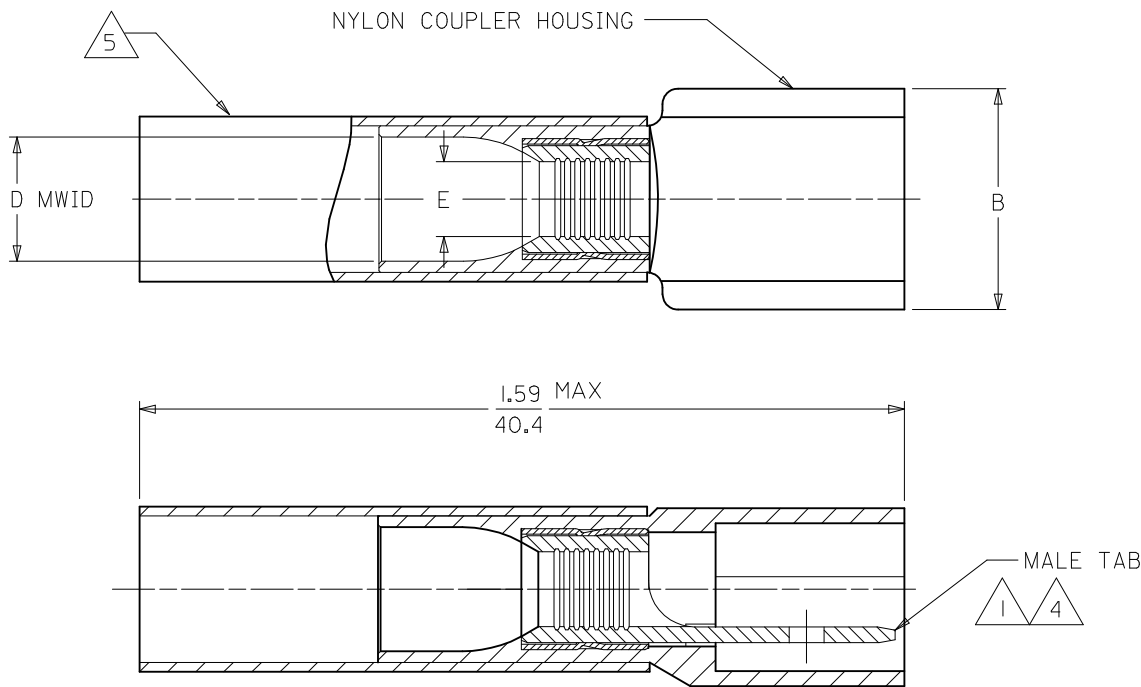

NOTES:

- 1. MALE TAB CONFORMS TO UL310.
- 2. ALL DIMENSIONS SHOWN ARE BEFORE SHRINK TUBING IS HEATED.
- 3. "MWID" DENOTES MAX. WIRE INSULATION DIA.
- 4. TAB MATERIAL: COPPER ALLOY, PLATING: TIN
- 5. NYLON HEAT SHRINKABLE TUBING WITH HOTMELT INNER LINER. SEE CHART FOR COLOR.
- 6. ALL PARTS ARE ROHS COMPLIANT.

SALES DRAWING

DELETE PART #S EC NO: PG2018-0080 G DRAWING: GRO/JAS01 2017/08/02 CHKD: JMACNEIL 2017/08/02 APPR: JMACNEIL 2017/08/23 REV DESCRIPTION	QUALITY SYMBOLS	GENERAL TOLERANCES (UNLESS SPECIFIED)	DIMENSION STYLE	SCALE	DESIGN UNITS	THIRD ANGLE PROJECTION	
	▼=0 ▽=0	mm INCH 4 PLACES ± --- ± --- 3 PLACES ± --- ± --- 2 PLACES ± --- ± --- 1 PLACE ± --- ± --- ANGULAR ± ---°	IN/MM	---	INCH	DRAWN BY DATE BRE 2002/10/25 CHECKED BY DATE HEB 2002/10/25 APPROVED BY DATE RWD 2002/10/25	TITLE PERMA-SEAL COUPLER MALE TAB TERMINAL 12-10 AWG
	DRAFT WHERE APPLICABLE MUST REMAIN WITHIN DIMENSIONS	SEE CHART	MATERIAL NO.	DOCUMENT NO.	SHEET NO.	MOLEX INCORPORATED SD-19164-039 1 OF 1	
	THIS DRAWING CONTAINS INFORMATION THAT IS PROPRIETARY TO MOLEX INCORPORATED AND SHOULD NOT BE USED WITHOUT WRITTEN PERMISSION						