

GENERAL DESCRIPTION

The SP338 is an advanced multiprotocol transceiver supporting RS-232, RS-485, and RS-422 serial standards in a 40 pin QFN package. Integrated cable termination and four configuration modes allow all three protocols to be used interchangeably over a single cable or connector with no additional switching components. Full operation requires only four external charge pump capacitors.

The RS-485/422 modes feature up to two drivers and four receivers (2TX/4RX) in half, full, and mixed duplex configurations. The RS-232 mode (3TX/5RX) provides full support of all eight signals commonly used with the DB9 RS-232 connector. A dedicated diagnostic loopback mode is also provided.

The high speed drivers operate up to 20Mbps in RS-485/422 modes, and up to 1Mbps in RS-232 mode. All drivers can be slew limited to 250kbps in any mode to minimize electromagnetic interference (EMI).

All transmitter outputs and receiver inputs feature robust electrostatic discharge (ESD) protection to $\pm 15\text{kV}$ Human Body Model (HBM) and $\pm 8\text{kV}$ IEC-61000-4-2 Contact. Each receiver output has full fail-safe protection to avoid system lockup, oscillation, or indeterminate states by defaulting to logic-high output level when the inputs are open, shorted, or terminated but undriven. No external biasing resistors are required.

The RS-232 receiver inputs include a $5\text{k}\Omega$ pull-down to ground. The RS-485/422 receiver inputs are high impedance ($>96\text{k}\Omega$ when termination is disabled), allowing up to 256 devices on a single communication bus (1/8th unit load).

The SP338 operates from a single power supply, either 3.3V or 5V, with low idle current. The shutdown mode consumes less than $10\mu\text{A}$ for low power standby operation.

ORDERING INFORMATION⁽¹⁾

PART NUMBER	OPERATING TEMPERATURE RANGE	LEAD-FREE	PACKAGE	PACKAGING METHOD
SP338EER1-L	-40°C to +85°C	Yes ⁽²⁾	40-pin QFN	Tray
SP338EER1-L/TR				Tape and Reel

NOTE:

1. Refer to www.exar.com/SP338E for most up-to-date Ordering Information.
2. Visit www.exar.com for additional information on Environmental Rating.

FEATURES

- Pin selectable Cable Termination
- No external resistors required for RS-485/422 termination and biasing
- 3.3V or 5V Single Supply Operation
- Robust ESD Protection on bus pins
 - $\pm 15\text{kV}$ Human Body Model (HBM)
 - $\pm 8\text{kV}$ IEC 61000-4-2 (Contact)
- Max Data Rate of 20Mbps in RS-485/422 Modes and up to 1Mbps in RS-232 Modes
- Pin selectable 250kbps Slew Limiting
- 3 Drivers, 5 Receivers RS-232/V.28
- 2 Drivers, 4 Receivers RS-485/422
 - Full, Half, and Mixed Duplex Configurations
 - 1/8th Unit Load, up to 256 receivers on bus
- RS-485/422 Enhanced Failsafe for open, shorted, or terminated but idle inputs
- Space saving 6mm x 6mm QFN-40 Package
- Pin compatible with SP339E

TYPICAL APPLICATIONS

- Dual Protocol Serial Ports (RS-232 or RS-485/422)
- Industrial Computers
- Industrial and Process Control Equipment
- Point-Of-Sale Equipment
- Networking Equipment
- HVAC Controls Equipment
- Building Security and Automation Equipment

ABSOLUTE MAXIMUM RATINGS

These are stress ratings only and functional operation of the device at these ratings or any other above those indicated in the operation sections to the specifications below is not implied. Exposure to absolute maximum rating conditions for extended periods of time may affect reliability and cause permanent damage to the device.

Supply Voltage V_{CC}	-0.3V to +6.0V
Receiver Input Voltage (from Ground)	$\pm 18V$
Driver Output Voltage (from Ground)	$\pm 18V$
Short Circuit Duration, TX out to Ground	Continuous
Voltage at TTL Input Pins	-0.3V to ($V_{CC} + 0.5V$)
Storage Temperature Range	-65°C to +150°C
Lead Temperature (soldering, 10s)	+300°C
Power Dissipation 40-pin QFN (derate 17mW/°C above +70°C)	500mW
ESD Ratings	
HBM - Human Body Model (Tx Output & Rx Input pins, R1-R9)	$\pm 15kV$
HBM - Human Body Model (All other pins)	$\pm 2kV$
IEC61000-4-2 Contact Discharge (Tx Output & Rx Input pins, R1-R9)	$\pm 8kV$

CAUTION:

ESD (ElectroStatic Discharge) sensitive device. Permanent damage may occur on unconnected devices subject to high energy electrostatic fields. Unused devices must be stored in conductive foam or shunts. Personnel should be properly grounded prior to handling this device. The protective foam should be discharged to the destination socket before devices are removed.

PIN DESCRIPTIONS BY MODE (MODE2, MODE1, MODE0)

Pin	Name	000, Figure 1	001, Figure 2	010, Figure 3	011, Figure 4	100, Figure 5	101, Figure 6	110, Figure 7	111, Figure 8
1	L1	R1 Output		1	1	1	1	1	1
2	L2	R2 Output		R1 Output	R1 Output	R1 Output	R1 Output	R1 Output	R1 Output
3	L3	T1 Input		T1 Input	T1 Input	T1 Input	T1 Input	T1 Input	T1 Input
4	L4	T2 Input							
5	L6	R3 Output		1	1	1	1	1	R2 Output
6	L7	T3 Input				T2 Input			T2 Input
7	L8	R4 Output		1	1	R2 Output	1	1	R3 Output
8	L9	R5 Output		1	1	1	1	1	R4 Output
9	VCC	V _{CC}							
10	GND	Ground							
11	SLEW	SLEW = V _{CC} enables 250kbps slew limiting							
12	DIR1			T1 Enable, R1 Disable	T1 Enable	T1 Enable	T1 Enable	T1 Enable, R1 Disable	T1 Enable, R1 Disable
13	DIR2					T2 Enable			T2 Enable, R2 Disable
14	MODE0	0	1	0	1	0	1	0	1
15	MODE1	0	0	1	1	0	0	1	1
16	MODE2	0	0	0	0	1	1	1	1
17	TERM	Enables RS-485/422 receiver termination							
18	INVDIR	Inverts DIR1 and DIR2, where applicable							
19	ENABLE	ENABLE = V _{CC} for operation, ENABLE = 0V for shutdown							
20	VCC	V _{CC}							

PIN DESCRIPTIONS BY MODE (MODE2, MODE1, MODE0)

Pin	Name	000, Figure 1	001, Figure 2	010, Figure 3	011, Figure 4	100, Figure 5	101, Figure 6	110, Figure 7	111, Figure 8
21	R9		R5 Input			R2 Input B	R1 Input B		R4 Input B
22	R8		R4 Input			R2 Input A			R4 Input A
23	GND	Ground							
24	R7		T3 Output			T2 Out A	R1 Input A		R3 Input A T2 Out A
25	R6		R3 Input			T2 Out B			R3 Input B T2 Out B
26	GND	Ground							
27	R4		T2 Output		R1 Input B	R1 Input B	T1 Out A	R1 Input A T1 Out A	R2 Input B
28	R3		T1 Output		R2 Input A	R1 Input A			R2 Input A
29	GND	Ground							
30	R2		R2 Input	R1 Input A T1 Out A	T1 Out A	T1 Out A			R1 Input A T1 Out A
31	R1		R1 Input	R1 Input B T1 Out B	T1 Out B	T1 Out B	T1 Out B	R1 Input B T1 Out B	R1 Input B T1 Out B
32	VCC	V _{CC}							
33	VSS	V _{SS} - Charge pump negative supply, 0.1uF from ground							
34	C2-	C ₂₊ - Charge pump cap 2 negative lead							
35	C1-	C ₁₋ - Charge pump cap 1 negative lead							
36	GND	Ground							
37	C1+	C ₁₊ - Charge pump cap 1 positive lead, 0.1uF							
38	VCC	V _{CC}							
39	C2+	C ₂₊ - Charge pump cap 2 positive lead, 0.1uF							
40	VDD	V _{DD} - Charge pump positive supply, 0.1uF to ground							

ELECTRICAL CHARACTERISTICS
UNLESS OTHERWISE NOTED:
 $V_{CC} = +3.3V \pm 5\%$ or $+5.0V \pm 5\%$, $C1-C4 = 0.1\mu F$; $T_A = T_{MIN}$ to T_{MAX} . Typical values are at $V_{CC} = 3.3V$, $T_A = +25^\circ C$.

SYMBOL	PARAMETERS	MIN.	TYP.	MAX.	UNITS	CONDITIONS
DC CHARACTERISTICS						
I_{CC}	Supply Current (RS-232)		2	10	mA	No load, idle inputs
I_{CC}	Supply Current (RS-485)		4	10	mA	No load, idle inputs
I_{CC}	Vcc Shutdown Current		1	10	μA	ENABLE = 0V
TRANSMITTER and LOGIC INPUT PINS: Pins 3, 4, 6, 11-19						
V_{IH}	Logic Input Voltage High	2.0			V	$V_{CC} = 3.3V$
V_{IH}	Logic Input Voltage High	2.4			V	$V_{CC} = 5.0V$
V_{IL}	Logic Input Voltage Low			0.8	V	
I_{IL}	Logic Input Leakage Current Low			1	μA	Input Low ($V_{IN} = 0V$)
I_{IH}	Logic Input Leakage Current High			1	μA	Input High ($V_{IN} = V_{CC}$), pins 3, 4 and 6
I_{PD}	Logic Input Pull-down Current			50	μA	Input High ($V_{IN} = V_{CC}$), pins 11-19
V_{HYS}	Logic Input Hysteresis		200		mV	
RECEIVER OUTPUTS: Pins 1, 2, 5, 7, 8						
V_{OH}	Receiver Output Voltage High	$V_{CC}-0.6$			V	$I_{OUT} = -1.5mA$
V_{OL}	Receiver Output Voltage Low			0.4	V	$I_{OUT} = 2.5mA$
I_{OSS}	Receiver Output ShortCircuit Current		± 20	± 60	mA	$0 \leq V_O \leq V_{CC}$
I_{OZ}	Receiver Output Leakage Current		± 0.1	± 1	μA	$0 \leq V_O \leq V_{CC}$, Receivers disabled

ELECTRICAL CHARACTERISTICS (Continued)

UNLESS OTHERWISE NOTED:

 $V_{CC} = +3.3V \pm 5\%$ or $+5.0V \pm 5\%$, $C1-C4 = 0.1\mu F$; $T_A = T_{MIN}$ to T_{MAX} . Typical values are at $V_{CC} = 3.3V$, $T_A = +25^\circ C$.

SYMBOL	PARAMETERS	MIN.	TYP.	MAX.	UNITS	CONDITIONS
SINGLE-ENDED RECEIVER INPUTS (RS-232)						
V_{IN}	Input Voltage Range	-15		+15	V	
V_{IL}	Input Threshold Low	0.6	1.2		V	$V_{CC} = 3.3V$
		0.8	1.5		V	$V_{CC} = 5.0V$
V_{IH}	Input Threshold High		1.5	2.0	V	$V_{CC} = 3.3V$
			1.8	2.4	V	$V_{CC} = 5.0V$
V_{HYS}	Input Hysteresis		0.3		V	
R_{IN}	Input Resistance	3	5	7	k Ω	$-15V \leq V_{IN} \leq +15V$
SINGLE-ENDED DRIVER OUTPUTS (RS-232)						
V_O	Output Voltage Swing	± 5.0	± 5.5		V	Output loaded with 3k Ω to Gnd
				± 7.0	V	No load output
I_{SC}	Short Circuit Current			± 60	mA	$V_O = 0V$
R_{OFF}	Power Off Impedance	300	10M		Ω	$V_{CC} = 0V$, $V_O = \pm 2V$

ELECTRICAL CHARACTERISTICS (Continued)
UNLESS OTHERWISE NOTED:
 $V_{CC} = +3.3V \pm 5\%$ or $+5.0V \pm 5\%$, $C1-C4 = 0.1\mu F$; $T_A = T_{MIN}$ to T_{MAX} . Typical values are at $V_{CC} = 3.3V$, $T_A = +25^\circ C$.

SYMBOL	PARAMETERS	MIN.	TYP.	MAX.	UNITS	CONDITIONS
DIFFERENTIAL RECEIVER INPUTS (RS-485 / RS-422)						
R_{IN}	Receiver Input Resistance	96			k Ω	TERM = 0V, $-7V \leq V_{IN} \leq +12V$
V_{TH}	Receiver Differential Threshold Voltage	-200	-125	-50	mV	
ΔV_{TH}	Receiver Input Hysteresis		25		mV	$V_{CM} = 0V$
I_{IN}	Receiver Input Current			125	μA	$V_{IN} = +12V$
				-100	μA	$V_{IN} = -7V$
R_{TERM}	Termination Resistance	100	120	155	Ω	TERM = V_{CC} , Figure 9 $-7V \leq V_{CM} \leq +12V$
R_{TERM}	Termination Resistance	100	120	140	Ω	TERM = V_{CC} , Figure 9 $V_{CM} = 0V$
DIFFERENTIAL DRIVER OUTPUTS (RS-485 / RS-422)						
V_{OD}	Differential Driver Output	2		V_{CC}	V	$R_L = 100\Omega$ (RS-422), Figure 10
		1.5		V_{CC}	V	$R_L = 54\Omega$ (RS-485), Figure 10
		1.5		V_{CC}	V	$V_{CM} = -7V$, Figure 11
		1.5		V_{CC}	V	$V_{CM} = +12V$, Figure 11
ΔV_{OD}	Change In Magnitude of Differential Output Voltage	-0.2		+0.2	V	$R_L = 54\Omega$ or 100Ω , Figure 10
V_{CM}	Driver CommonMode Output Voltage			3	V	$R_L = 54\Omega$ or 100Ω , Figure 10
ΔV_{CM}	Change In Magnitude of Common Mode Output Voltage			0.2	V	$R_L = 54\Omega$ or 100Ω , Figure 10
I_{OSD}	Driver Output Short Circuit Current			± 250	mA	$-7V \leq V_O \leq +12V$, Figure 12
I_O	Driver Output Leakage Current			± 100	μA	ENABLE = 0V, or DIR1 = 0V and DIR2 = 0V in full duplex modes, $-7V \leq V_O \leq +12V$

TIMING CHARACTERISTICS

UNLESS OTHERWISE NOTED:

 $V_{CC} = +3.3V \pm 5\%$ or $+5.0V \pm 5\%$, $C1-C4 = 0.1\mu F$; $T_A = T_{MIN}$ to T_{MAX} . Typical values are at $V_{CC} = 3.3V$, $T_A = +25^\circ C$.

SYMBOL	PARAMETERS	MIN.	TYP.	MAX.	UNITS	CONDITIONS
ALL MODES						
t_{ENABLE}	Enable from Shutdown		1000		ns	
$t_{SHUTDOWN}$	Enable to Shutdown		1000		ns	
RS-232, DATA RATE = 250kbps (SLEW = Vcc), ONE TRANSMITTER SWITCHING						
	Maximum Data Rate	250			kbps	$R_L = 3k\Omega$, $C_L = 1000pF$
t_{RHL} , t_{RLH}	Receiver Propagation Delay		100		ns	$C_L = 150pF$, Figure 13
$ t_{RHL} - t_{RLH} $	Receiver Propagation Delay Skew			100	ns	
t_{DHL} , t_{DLH}	Driver Propagation Delay		1400		ns	$R_L = 3k\Omega$, $C_L = 2500pF$, Figure 14
$ t_{DHL} - t_{DLH} $	Driver Propagation Delay Skew			600	ns	
t_{SHL} , t_{SLH}	Transition Region Slew Rate from +3.0V to -3.0V or -3.0V to +3.0V	4		30	V/ μs	$V_{CC} = 3.3V$, $R_L = 3k\Omega$ to $7k\Omega$, $C_L = 150pF$ to $2500pF$, Figure 14
t_{SHL} , t_{SLH}	Transition Region Slew Rate from +3.0V to -3.0V or -3.0V to +3.0V	6		30	V/ μs	$V_{CC} = 3.3V$, $R_L = 3k\Omega$ to $7k\Omega$, $C_L = 150pF$ to $2500pF$, $T_A = 25^\circ C$, Figure 14
RS-232, DATA RATE = 1Mbps (SLEW = 0V), ONE TRANSMITTER SWITCHING						
	Maximum Data Rate	1			Mbps	$R_L = 3k\Omega$, $C_L = 250pF$
t_{RHL} , t_{RLH}	Receiver Propagation Delay		100		ns	$C_L = 150pF$, Figure 13
$ t_{RHL} - t_{RLH} $	Receiver Propagation Delay Skew			100	ns	
t_{DHL} , t_{DLH}	Driver Propagation Delay		300		ns	$R_L = 3k\Omega$, $C_L = 1000pF$, Figure 14
$ t_{DHL} - t_{DLH} $	Driver Propagation Delay Skew			150	ns	
t_{SHL} , t_{SLH}	Transition Region Slew Rate from +3.0V to -3.0V or -3.0V to +3.0V	15		150	V/ μs	$V_{CC} = 3.3V$, $R_L = 3k\Omega$ to $7k\Omega$, $C_L = 150pF$ to $1000pF$, Figure 14
t_{SHL} , t_{SLH}	Transition Region Slew Rate from +3.0V to -3.0V or -3.0V to +3.0V	24		150	V/ μs	$V_{CC} = 3.3V$, $R_L = 3k\Omega$ to $7k\Omega$, $C_L = 150pF$ to $1000pF$, $T_A = 25^\circ C$, Figure 14

TIMING CHARACTERISTICS (Continued)
UNLESS OTHERWISE NOTED:
 $V_{CC} = +3.3V \pm 5\%$ or $+5.0V \pm 5\%$, $C_1-C_4 = 0.1\mu F$; $T_A = T_{MIN}$ to T_{MAX} . Typical values are at $V_{CC} = 3.3V$, $T_A = +25^\circ C$.

SYMBOL	PARAMETERS	MIN.	TYP.	MAX.	UNITS	CONDITIONS
RS-485/RS-422, DATA RATE = 250kbps (SLEW = V_{CC}), ONE TRANSMITTER SWITCHING						
	Maximum Data Rate	250			kbps	$R_L = 54\Omega$, $C_L = 50pF$
t_{RPHL} , t_{RPLH}	Receiver Propagation Delay		50	150	ns	$C_L = 15pF$, Figure 15
$ t_{RPHL} - t_{RPLH} $	Receiver Propagation Delay Skew			20	ns	
t_{DPHL} , t_{DPLH}	Driver Propagation Delay		500	1000	ns	$R_L = 54\Omega$, $C_L = 50pF$, Figure 16
$ t_{DPHL} - t_{DPLH} $	Driver Propagation Delay Skew			100	ns	
t_{DR} , t_{DF}	Driver Rise and Fall Time	300	650	1200	ns	
RS-485/RS-422, DATA RATE = 20Mbps (SLEW = 0V), ONE TRANSMITTER SWITCHING						
	Maximum Data Rate	20			Mbps	$R_L = 54\Omega$, $C_L = 50pF$
t_{RPHL} , t_{RPLH}	Receiver Propagation Delay		50	150	ns	$C_L = 15pF$, Figure 15
$ t_{RPHL} - t_{RPLH} $	Receiver Propagation Delay Skew			10	ns	
t_{DPHL} , t_{DPLH}	Driver Propagation Delay		30	100	ns	$R_L = 54\Omega$, $C_L = 50pF$, Figure 16
$ t_{DPHL} - t_{DPLH} $	Driver Propagation Delay Skew			10	ns	
t_{DR} , t_{DF}	Driver Rise and Fall Time		10	20	ns	
t_{RZH} , t_{RZL}	Receiver Output Enable Time			200	ns	$C_L = 15pF$, Figure 17
t_{RHZ} , t_{RLZ}	Receiver Output Disable Time			200	ns	
t_{DZH} , t_{DZL}	Driver Output Enable Time			200	ns	$R_L = 500\Omega$, $C_L = 50pF$, Figure 18
t_{DHZ} , t_{DLZ}	Driver Output Disable Time			200	ns	

BLOCK DIAGRAM BY MODE (MODE2, MODE1, MODE0)

FIGURE 1. MODE 000 - LOOPBACK

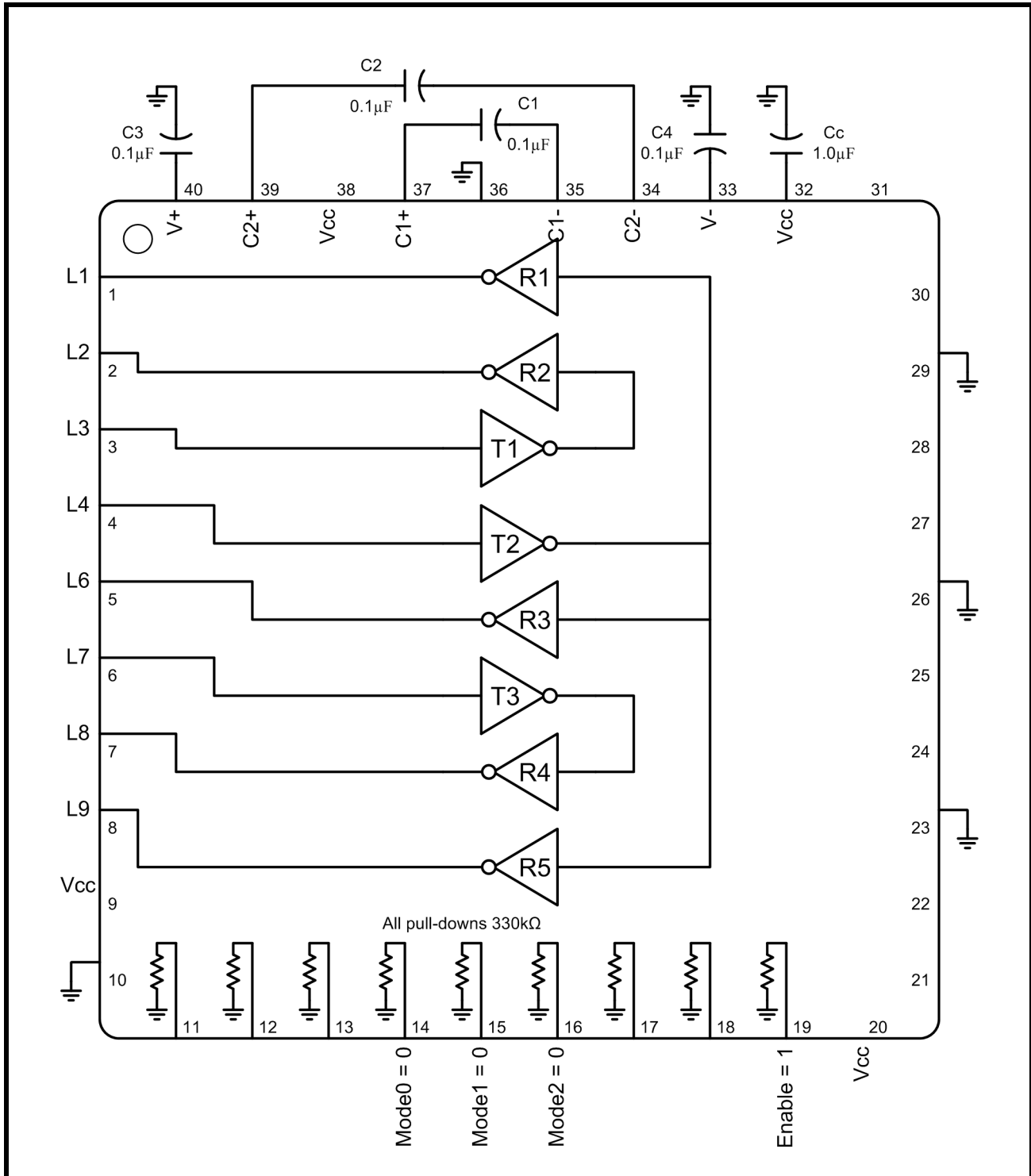

FIGURE 2. MODE 001 - RS-232

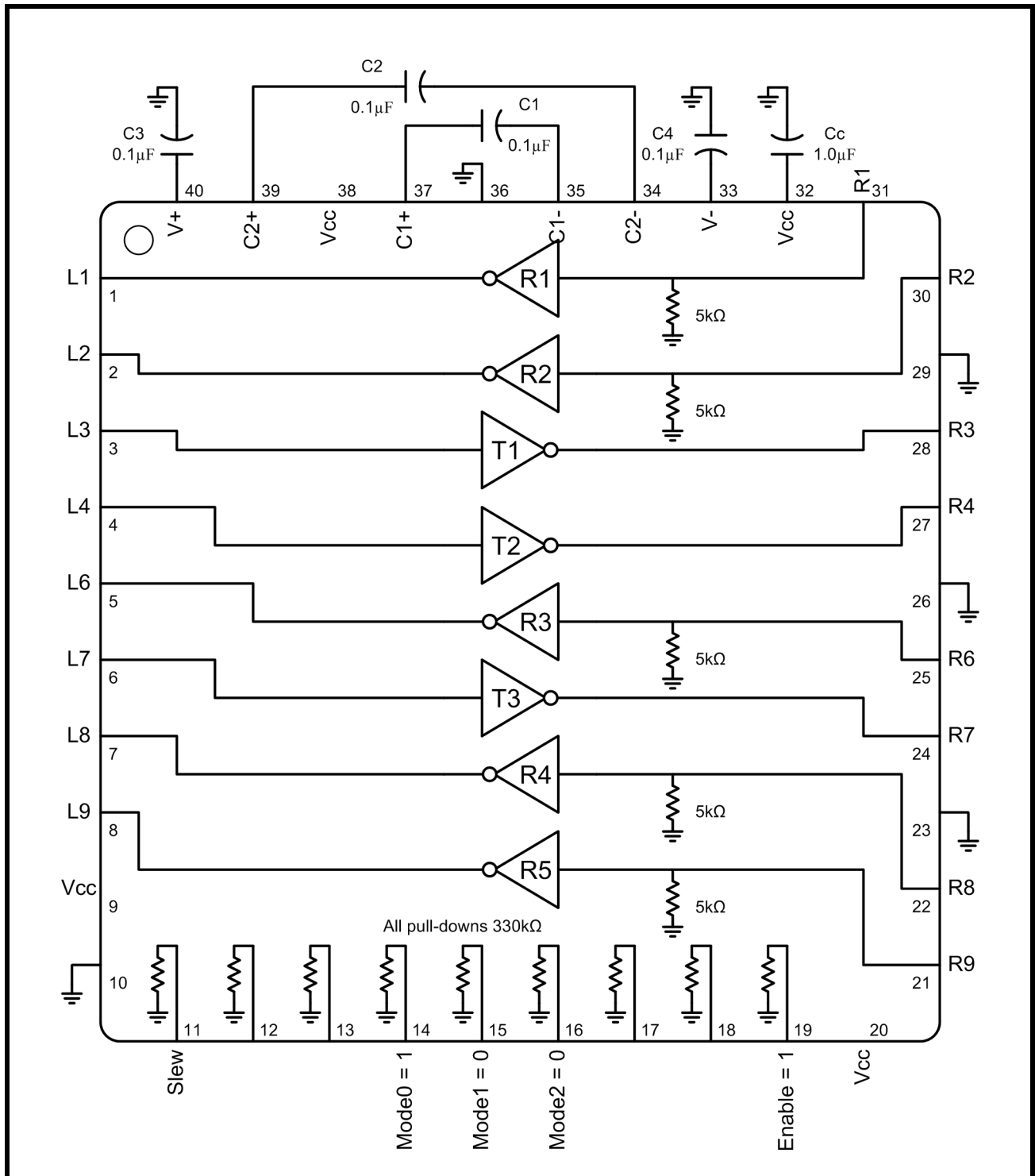

FIGURE 3. MODE 010 - RS-485 HALF DUPLEX #1

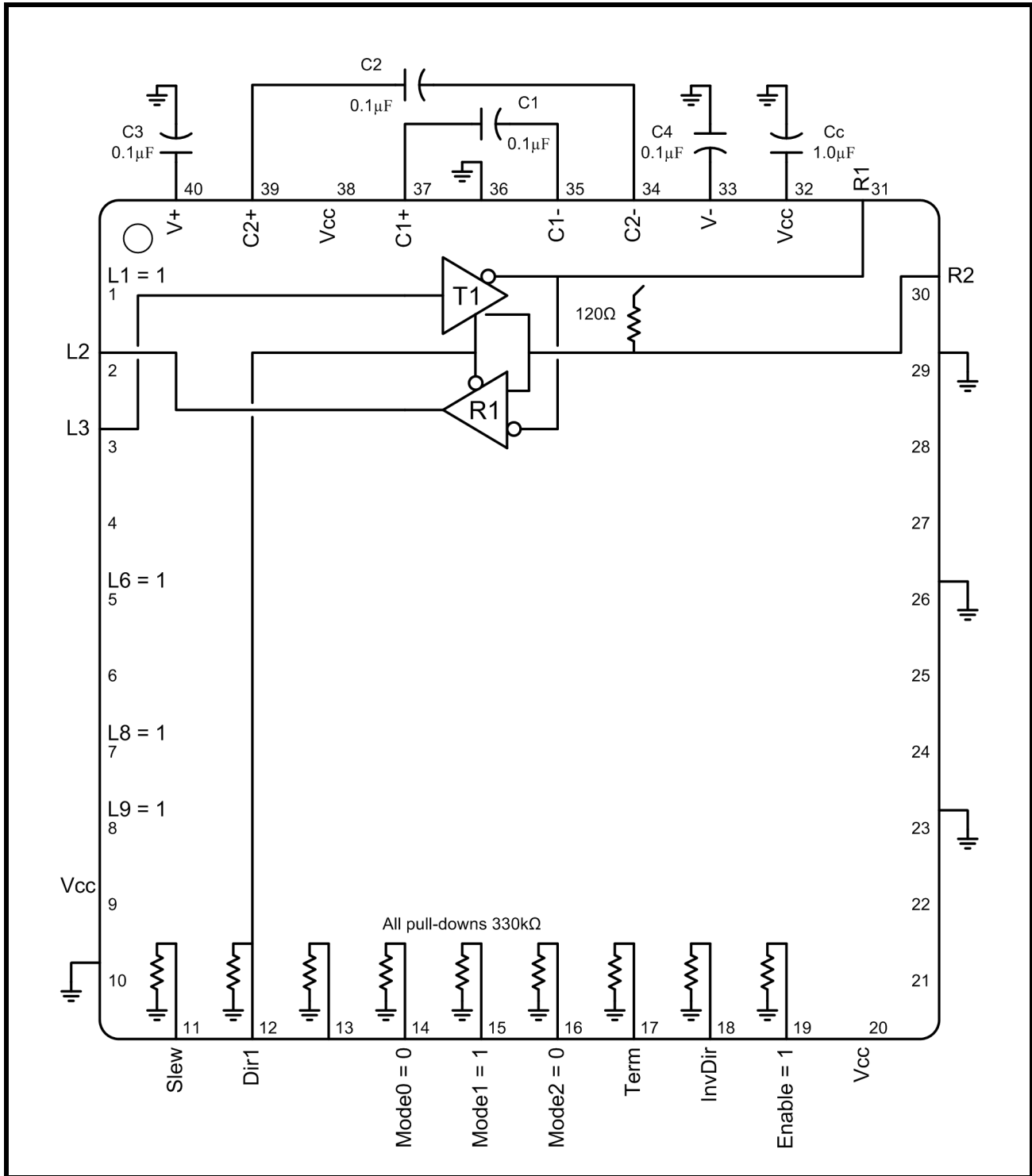

FIGURE 4. MODE 011 - RS-485/422 FULL DUPLEX #1

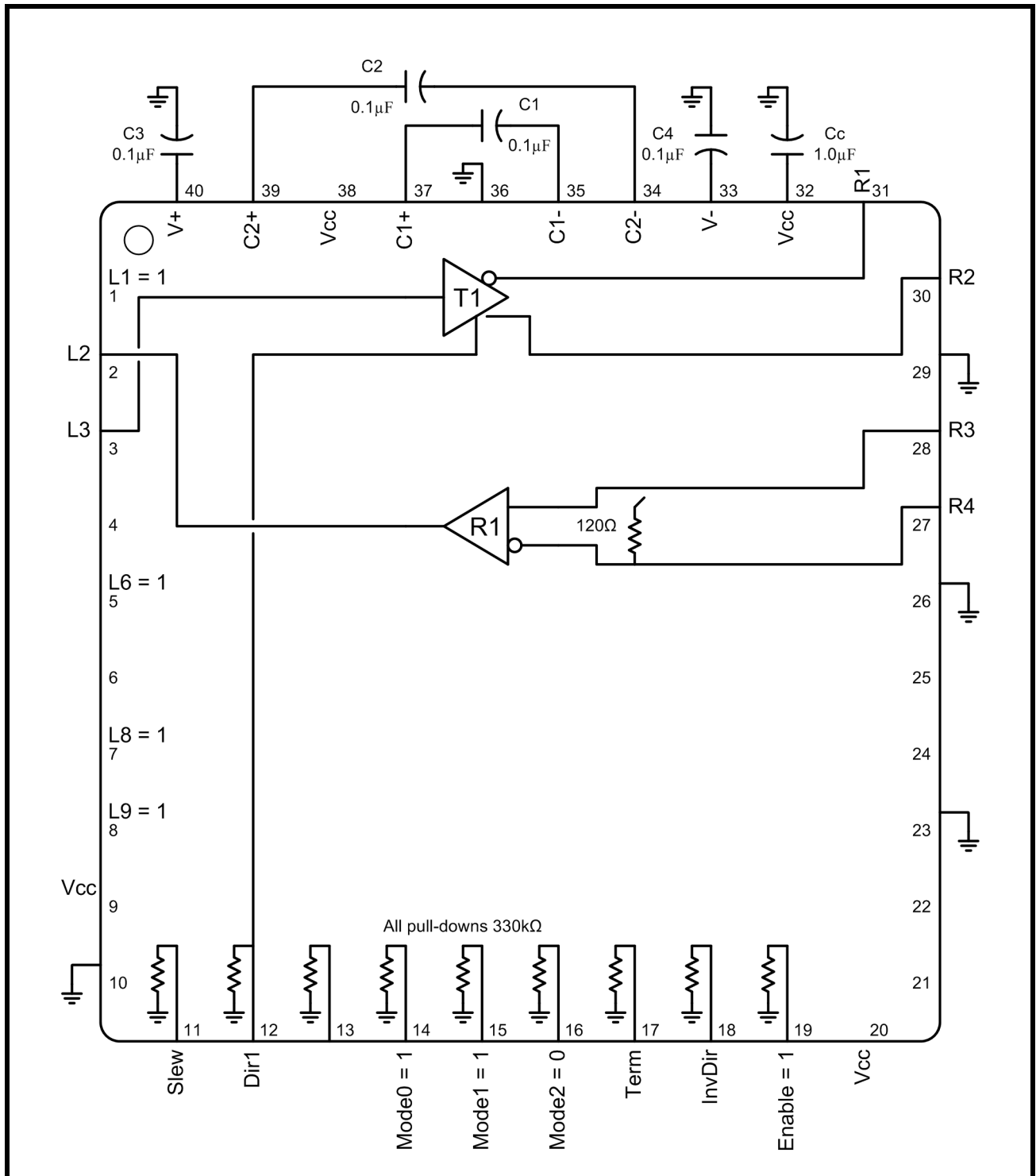

FIGURE 5. MODE 100 - RS-485/422 FULL DUPLEX #2

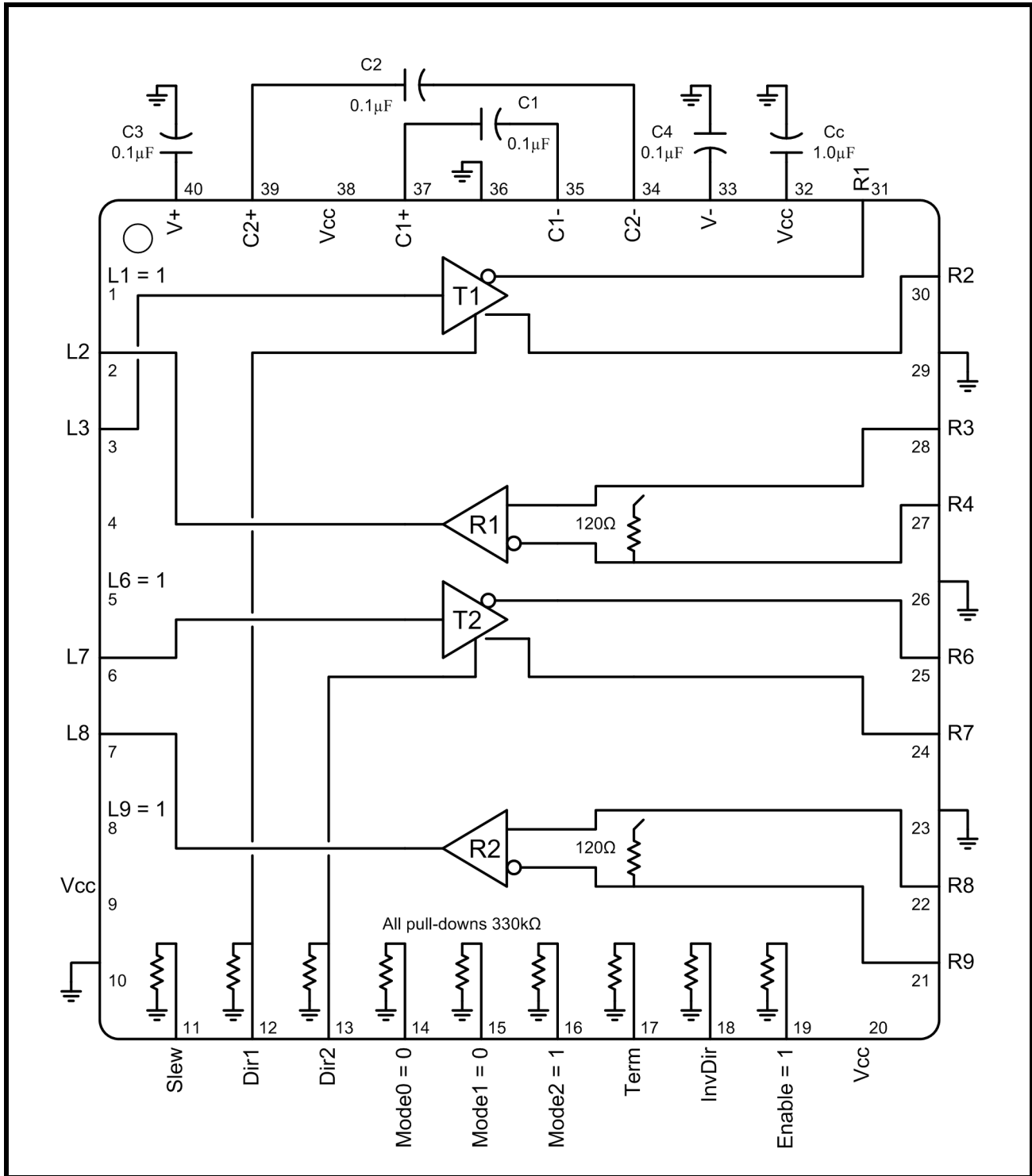

FIGURE 6. MODE 101 - RS-485/422 FULL DUPLEX #3

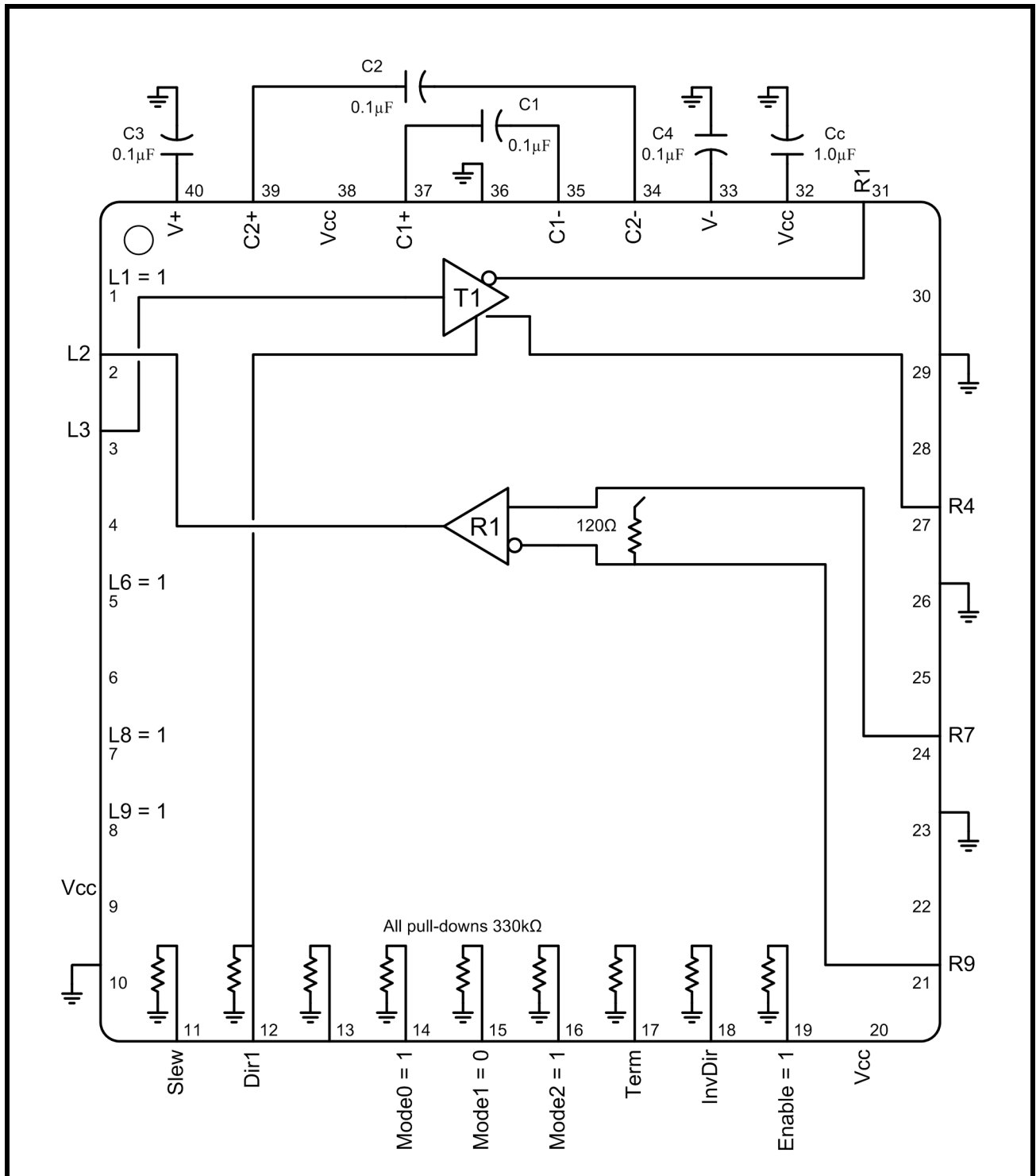

FIGURE 7. MODE 110 - RS-485 HALF DUPLEX #2

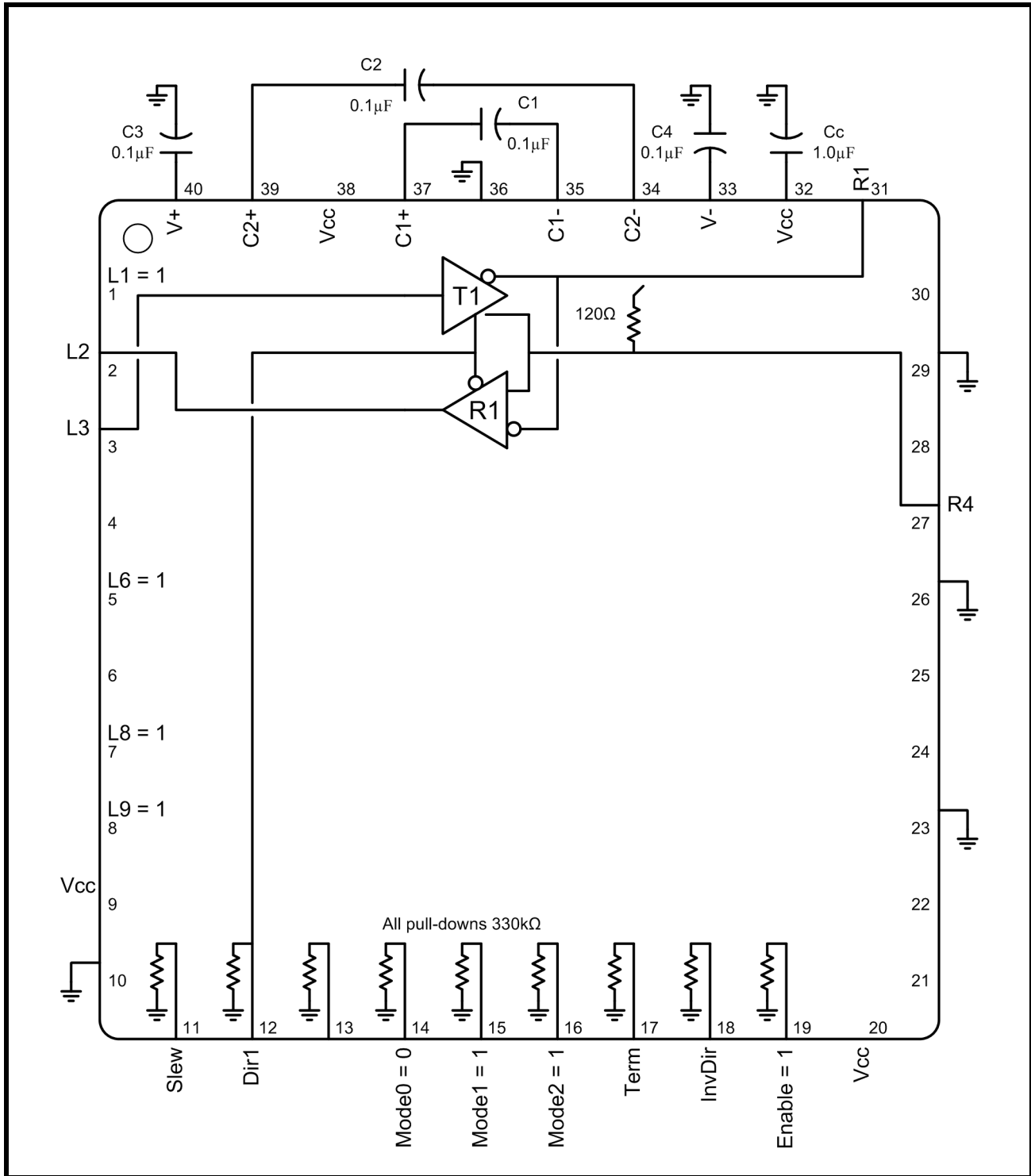
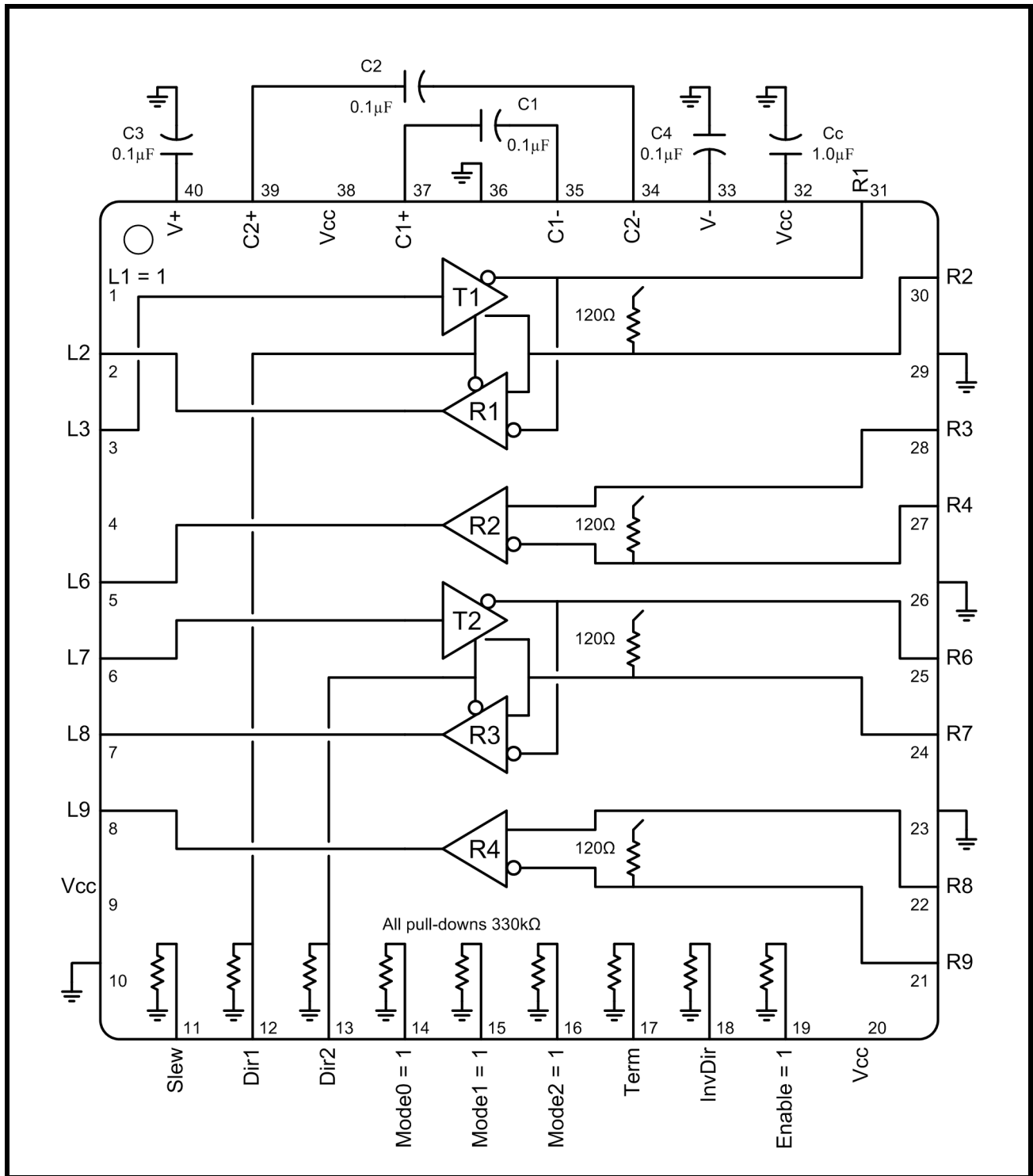

FIGURE 8. MODE 111 - RS-485/422 MIXED DUPLEX



TEST FIXTURES

FIGURE 9. RS-485/422 RECEIVER TERMINATION RESISTANCE

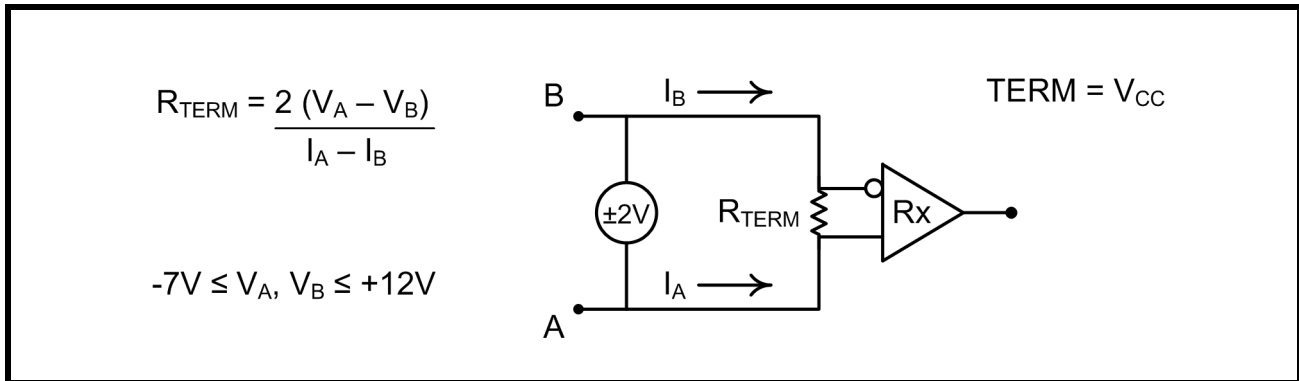

FIGURE 10. RS-485/422 DIFFERENTIAL DRIVER OUTPUT VOLTAGE

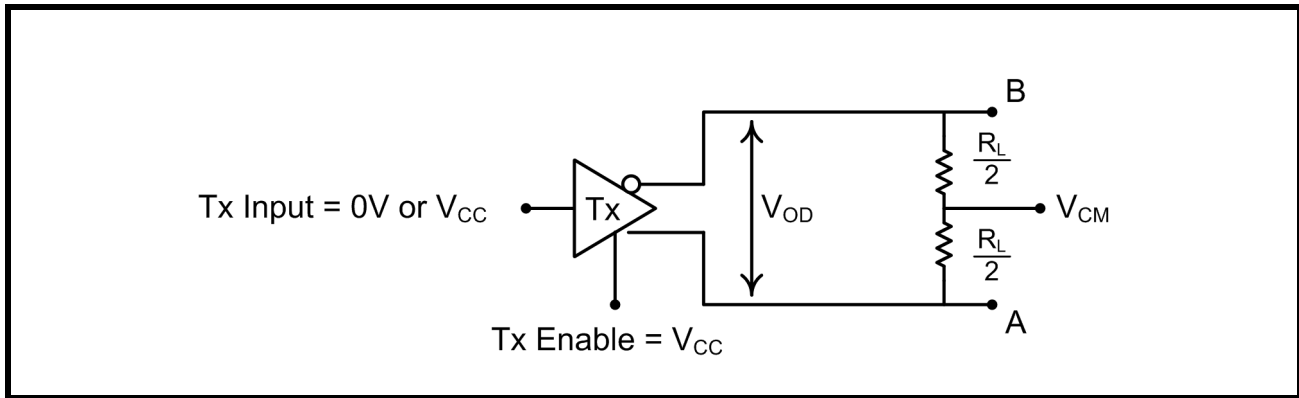

FIGURE 11. RS-485/422 DIFFERENTIAL DRIVER OUTPUT VOLTAGE OVER COMMON MODE

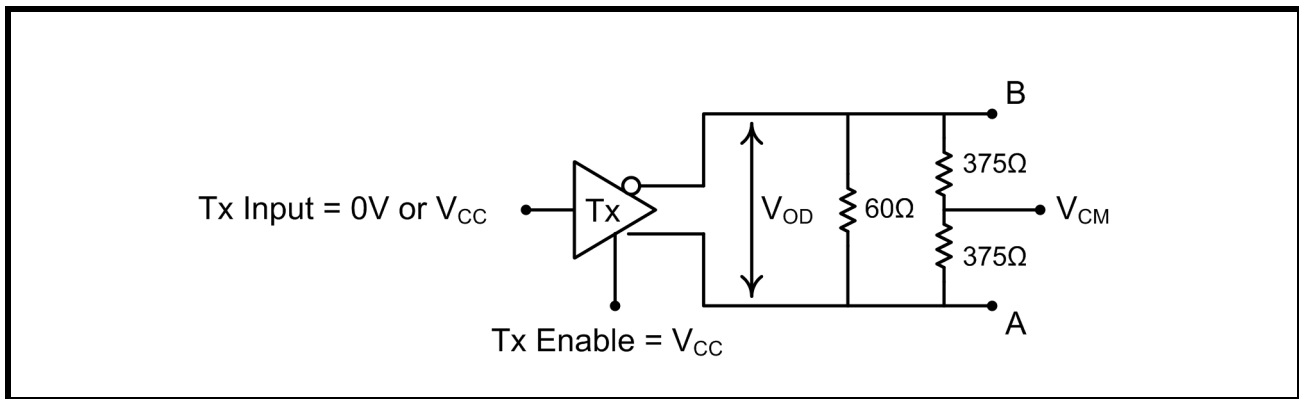

FIGURE 12. RS-485/422 DRIVER OUTPUT SHORT CIRCUIT CURRENT

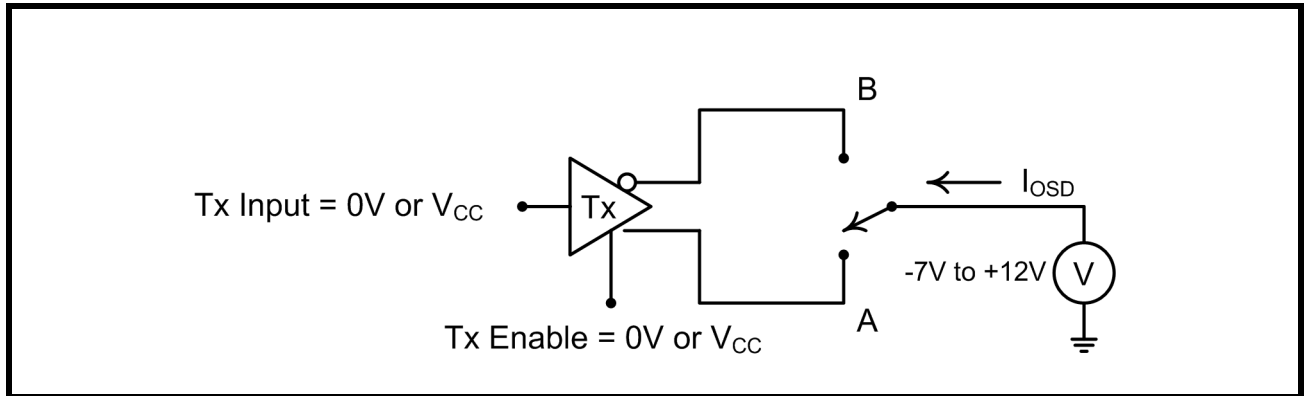

FIGURE 13. RS-232 RECEIVER PROPAGATION DELAY

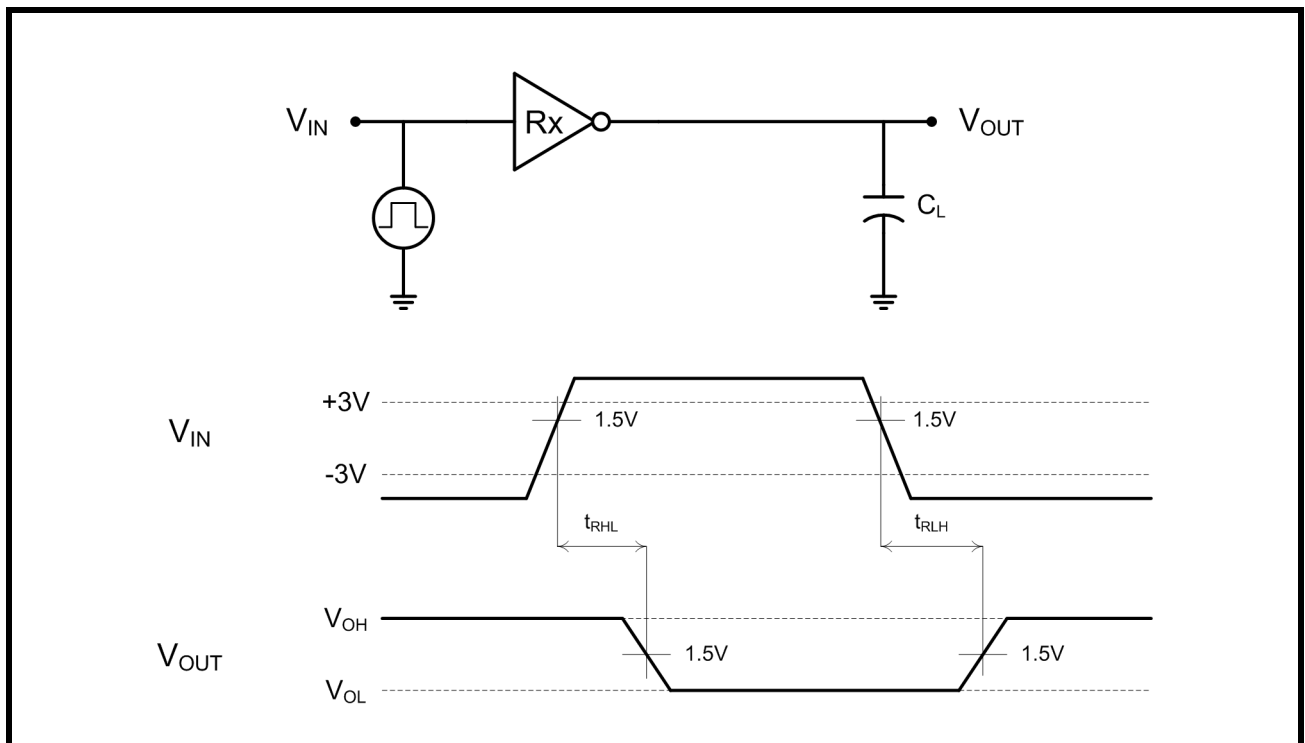

FIGURE 14. RS-232 DRIVER PROPAGATION DELAY

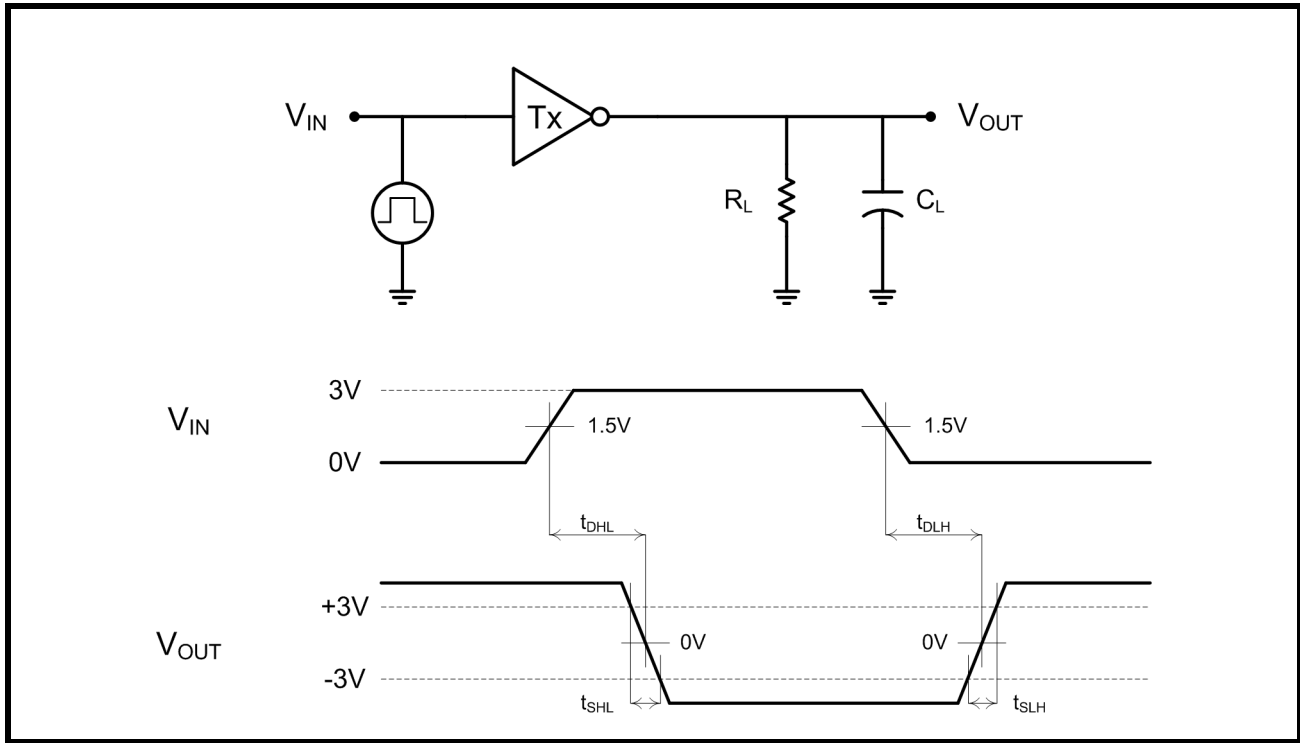

FIGURE 15. RS-485/422 RECEIVER PROPAGATION DELAY

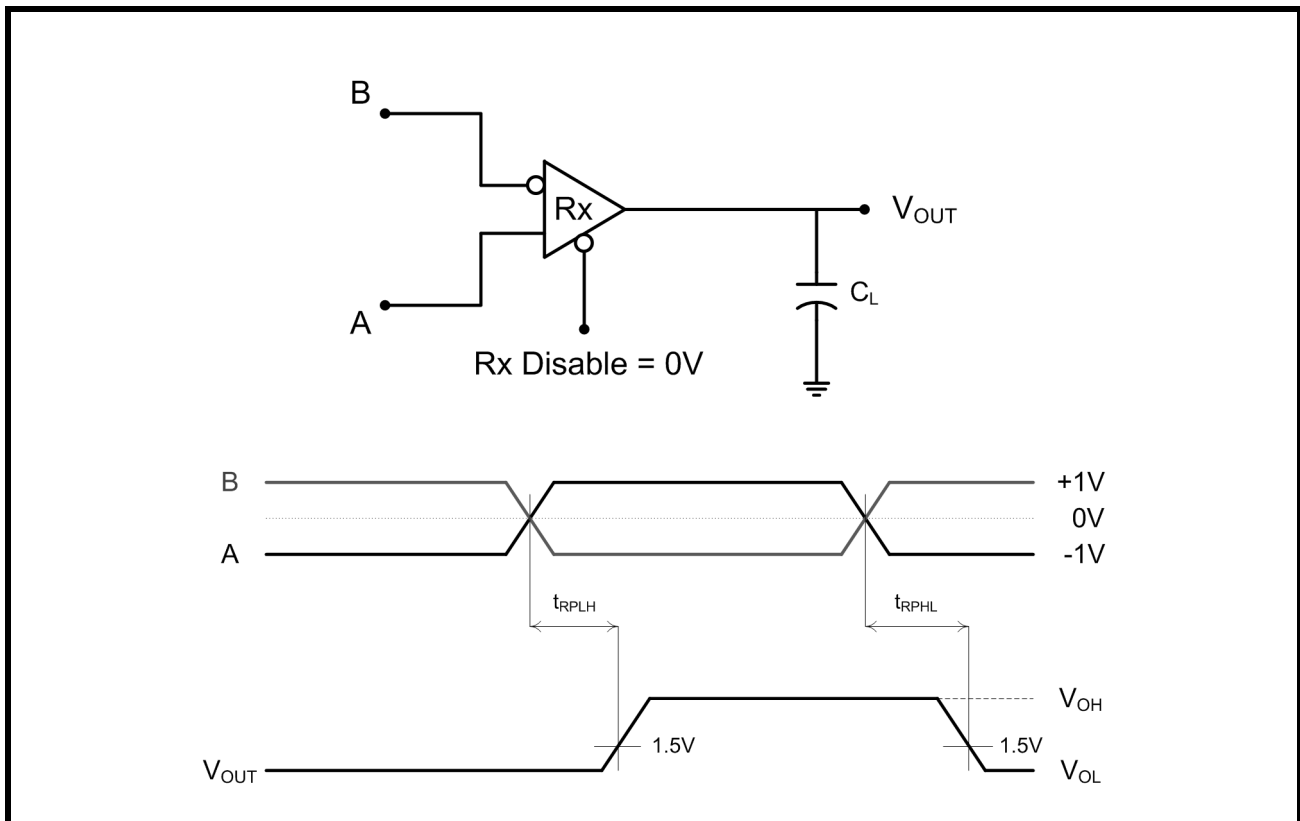

FIGURE 16. RS-485/422 DRIVER PROPAGATION DELAY AND RISE/FALL TIMES

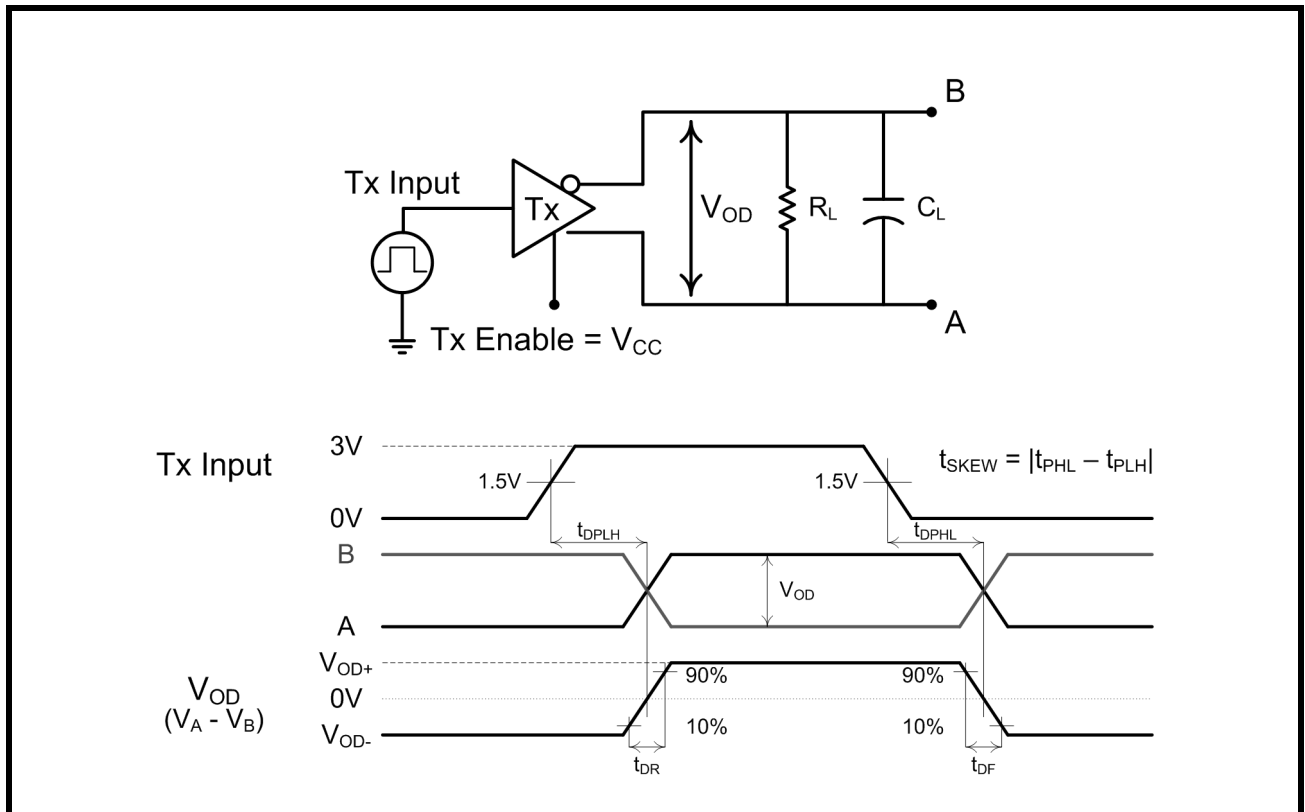

FIGURE 17. RS-485/422 RECEIVER OUTPUT ENABLE/DISABLE TIMES

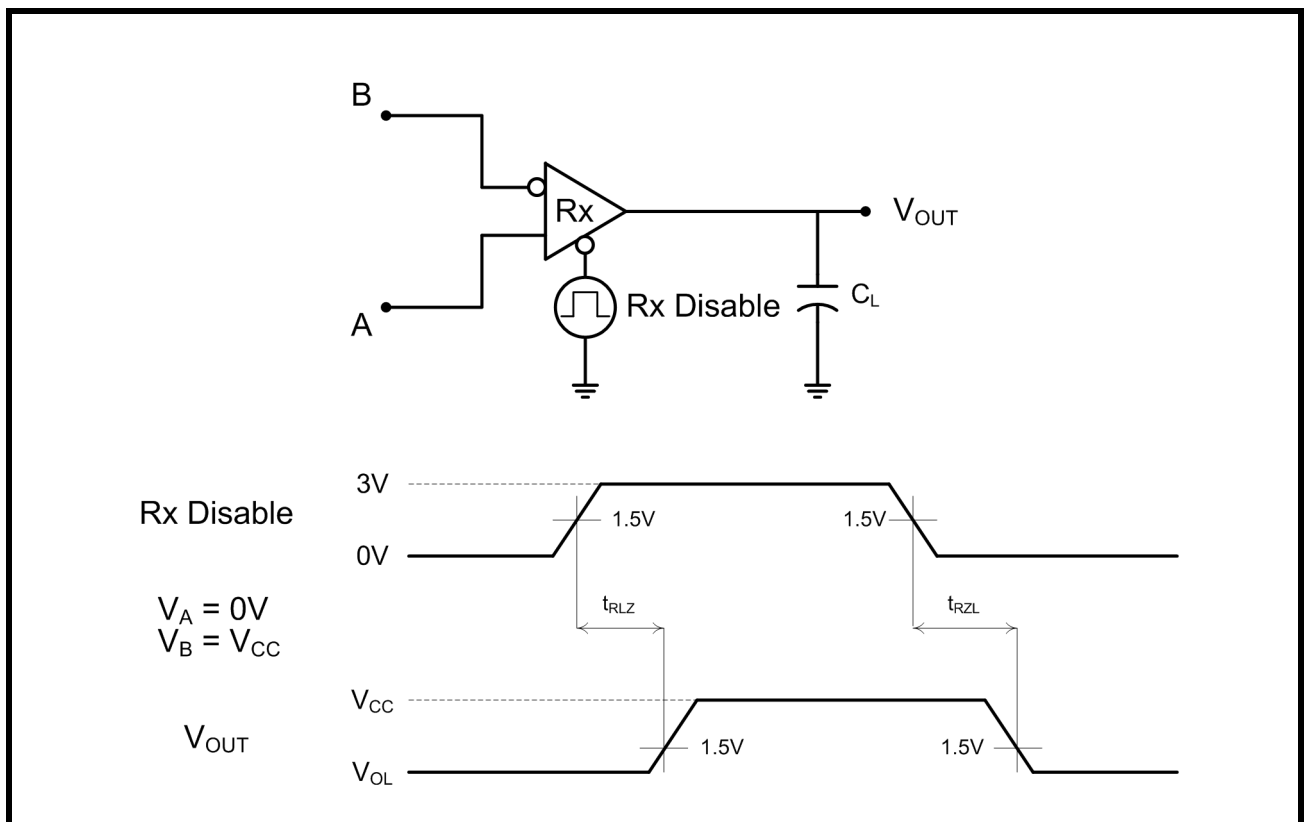
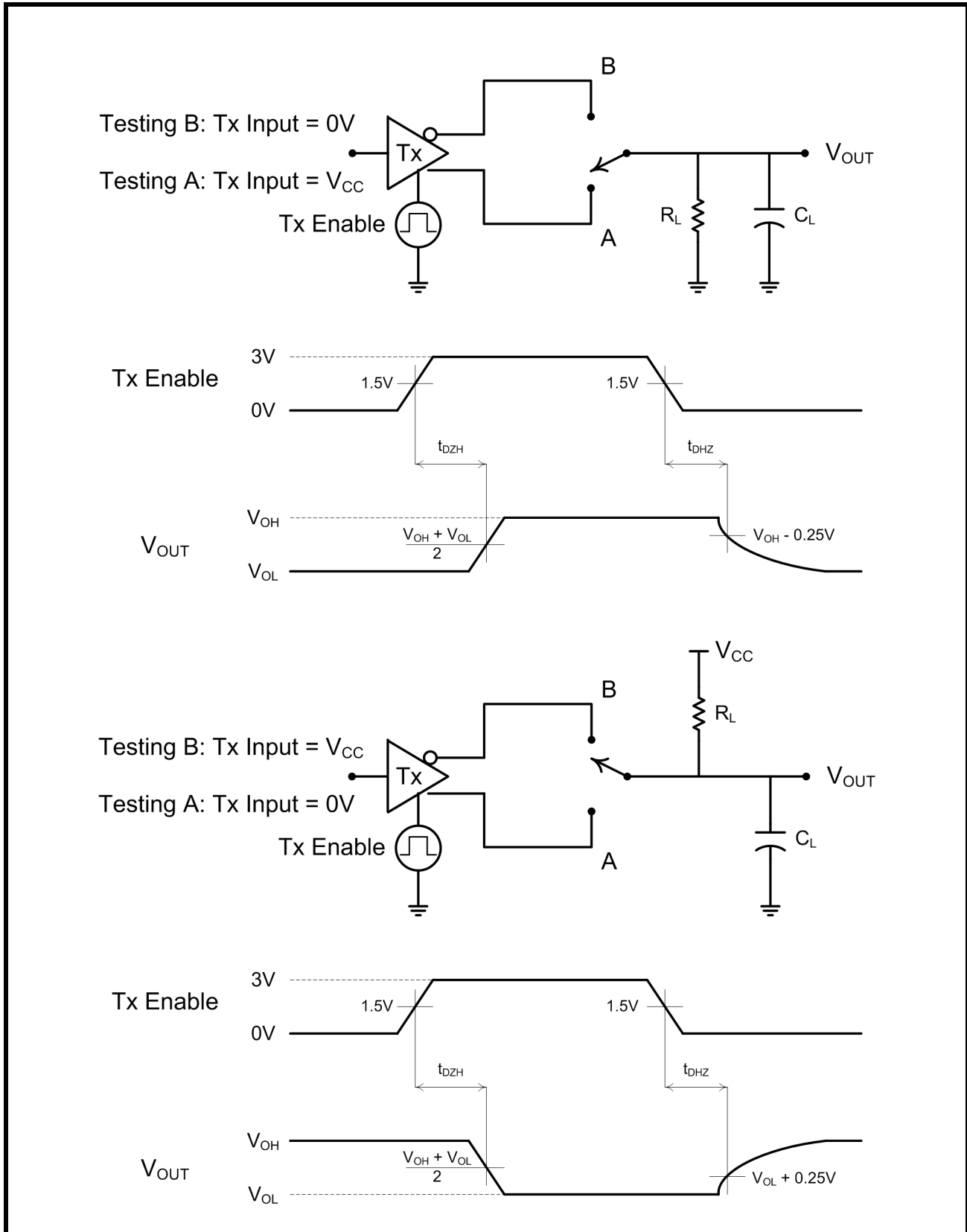

FIGURE 18. RS-485/422 DRIVER OUTPUT ENABLE/DISABLE TIMES



PRODUCT SUMMARY

The SP338 is an advanced multiprotocol transceiver supporting RS-232, RS-485, and RS-422 serial standards in a 40 pin QFN package. Integrated cable termination and four configuration modes allow all three protocols to be used interchangeably over a single cable or connector with no additional switching components. The RS-485/422 modes feature up to two drivers and four receivers (2TX/4RX) in half, full, and mixed duplex configurations. The RS-232 mode (3TX/5RX) provides full support of all eight signals commonly used with the DB9 RS-232 connector. A dedicated mode is also available for diagnostic loopback testing.

INTERNALLY SWITCHED CABLE TERMINATION

Enabling and disabling the RS-485/422 termination resistor is one of the largest challenges system designers face when sharing a single connector or pair of lines between multiple serial protocols. A termination resistor may be necessary for accurate RS-485/422 communication, but must be removed when the lines are used for RS-232. SP338 provides an elegant solution to this problem by integrating the termination resistor and switching control, and allowing it to be switched in and out of the circuit with a single pin. No external switching components are required.

ENHANCED FAILSAFE

Ordinary RS-485 differential receivers will be in an indeterminate state whenever the data bus is not being actively driven. The enhanced failsafe feature of the SP338 guarantees a logic-high receiver output when the receiver inputs are open, shorted, or terminated but idle/undriven. The enhanced failsafe interprets 0V differential as a logic high with a minimum 50mV noise margin, while maintaining compliance with the EIA/TIA-485 standard of $\pm 200\text{mV}$. No external biasing resistors are required, further easing the usage of multiple protocols over a single connector.

$\pm 15\text{kV}$ ESD PROTECTION

ESD protection structures are incorporated on all pins to protect against electrostatic discharges encountered during handling and assembly. The bus pins (driver outputs and receiver inputs) have extra protection structures, which have been tested up to $\pm 15\text{kV}$ without damage. These structures withstand high ESD in all states: normal operation, shutdown and powered down.

ESD protection is tested in various ways. Maxlinear uses the following methods to qualify the protection structures designed into SP338:

- $\pm 15\text{kV}$ using the Human Body Model (HBM)

- $\pm 8\text{kV}$ using IEC 61000-4-2 Contact Discharge

The IEC 61000-4-2 standard is more rigorous than HBM, resulting in lower voltage levels compared with HBM for the same level of ESD protection. Because IEC 61000-4-2 specifies a lower series resistance, the peak current is higher than HBM. The SP338 has passed both HBM and IEC 61000-4-2 testing without damage.

DIAGNOSTIC LOOPBACK MODE

The SP338 includes a diagnostic digital loop back mode for system testing as shown in [Figure 1](#). The loopback mode connects the TTL driver inputs to the TTL receiver outputs, bypassing the analog driver and receiver circuitry. The analog/bus pins are internally disconnected in this mode.

MECHANICAL DIMENSIONS

FIGURE 19. QFN40

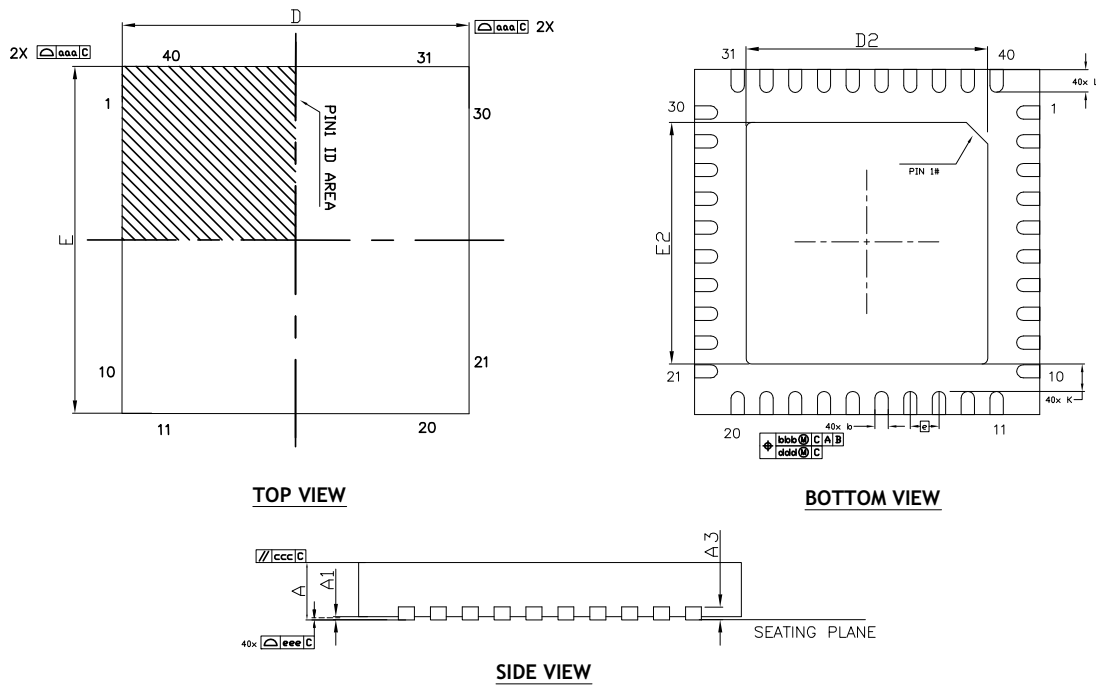

DIMENSION TABLE				
SYMBOL	MIN	NOM	MAX	NOTE
A	0.80	0.90	1.00	
A1	0.00	0.02	0.05	
A3	---	0.20Ref	---	
b	0.20	0.25	0.30	
D	6.00 BSC			
E	6.00 BSC			
e	0.50 BSC			
D2	4.50	4.65	4.80	
E2	4.50	4.65	4.80	
L	0.35	0.40	0.45	
K	0.20	-	-	
aaa		0.15		
bbb		0.10		
ccc		0.10		
ddd		0.05		
eee		0.08		
N		40		

TERMINAL DETAILS

- ALL DIMENSIONS ARE IN MILLIMETERS, ANGLES ARE IN DEGREES.
- DIMENSIONS AND TOLERANCE PER JEDEC MO-220.

Drawing No.: POD-00000041

Revision: B.3

RECOMMENDED LAND PATTERN AND STENCILS

FIGURE 20. QFN40

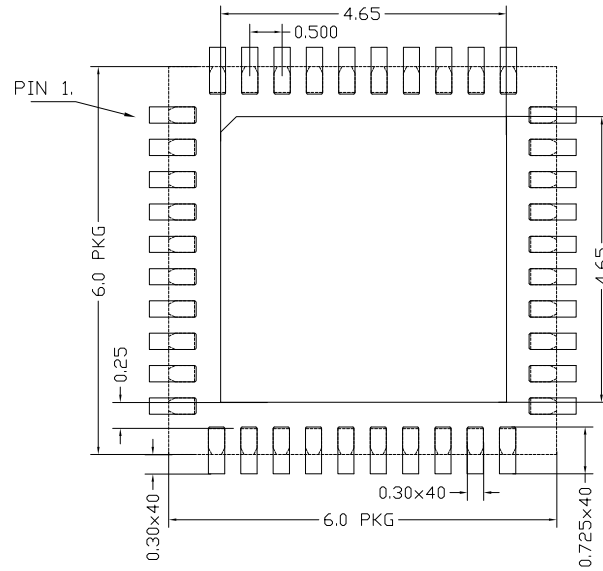

TYPICAL RECOMMENDED LAND PATTERN

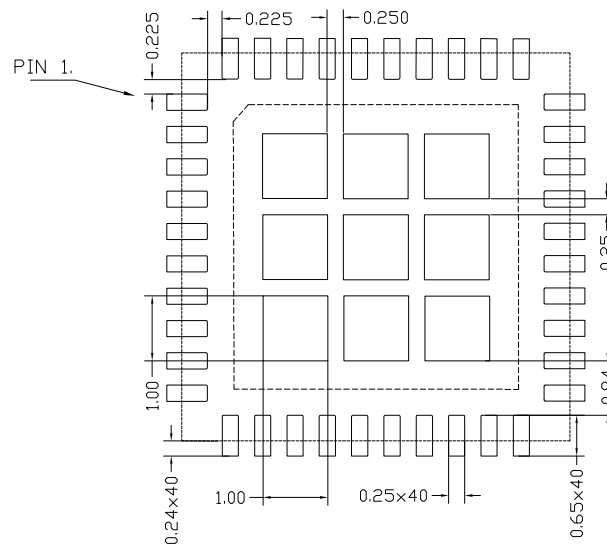

TYPICAL RECOMMENDED STENCIL

Drawing No.: POD-00000041

Revision: B.3

REVISION HISTORY

DATE	REVISION	DESCRIPTION
November 2011	1.0.0	Production Release
February 2018	1.0.1	Update to MaxLinear logo. Update format and Ordering Information. Moved ESD ratings on page 2.
January 2019	1.0.2	Correct typo in recommended stencil.

**Corporate Headquarters:**

5966 LaPlace Court
 Suite 100
 Carlsbad, CA 92008
 Tel.:+1 (760) 692-0711
 Fax:+1 (760) 444-8598
www.maxlinear.com

The content of this document is furnished for informational use only, is subject to change without notice, and should not be construed as a commitment by MaxLinear, Inc.. MaxLinear, Inc. assumes no responsibility or liability for any errors or inaccuracies that may appear in the informational content contained in this guide. Complying with all applicable copyright laws is the responsibility of the user. Without limiting the rights under copyright, no part of this document may be reproduced into, stored in, or introduced into a retrieval system, or transmitted in any form or by any means (electronic, mechanical, photocopying, recording, or otherwise), or for any purpose, without the express written permission of MaxLinear, Inc.

MaxLinear, Inc. does not recommend the use of any of its products in life support applications where the failure or malfunction of the product can reasonably be expected to cause failure of the life support system or to significantly affect its safety or effectiveness. Products are not authorized for use in such applications unless MaxLinear, Inc. receives, in writing, assurances to its satisfaction that: (a) the risk of injury or damage has been minimized; (b) the user assumes all such risks; (c) potential liability of MaxLinear, Inc. is adequately protected under the circumstances.

MaxLinear, Inc. may have patents, patent applications, trademarks, copyrights, or other intellectual property rights covering subject matter in this document. Except as expressly provided in any written license agreement from MaxLinear, Inc., the furnishing of this document does not give you any license to these patents, trademarks, copyrights, or other intellectual property.

Company and product names may be registered trademarks or trademarks of the respective owners with which they are associated.

© 2011 - 2019 MaxLinear, Inc. All rights reserved