

THIS DRAWING IS UNPUBLISHED. RELEASED FOR PUBLICATION SEP ,2007.
 © COPYRIGHT 2007 By - ALL RIGHTS RESERVED.

LOC	DIST	REVISIONS			
P	LTR	DESCRIPTION	DATE	DWN	APVD
J	/				
	C	REVISED PER ECR-12-004002	01MAR2012	W.W	C.W

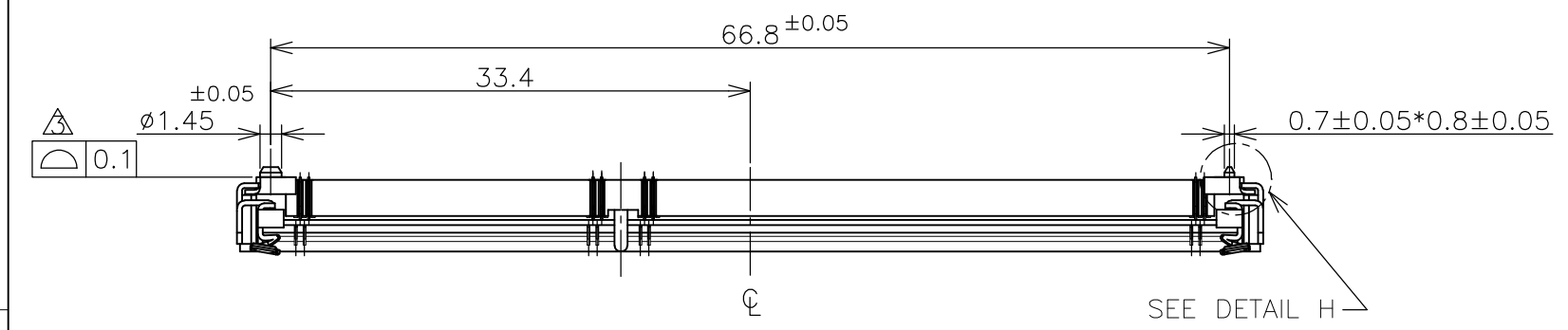

HOW TO MATE AND UNMATE



RECOMMENDED MATING P.C.B OUTLINE
71.5±0.5

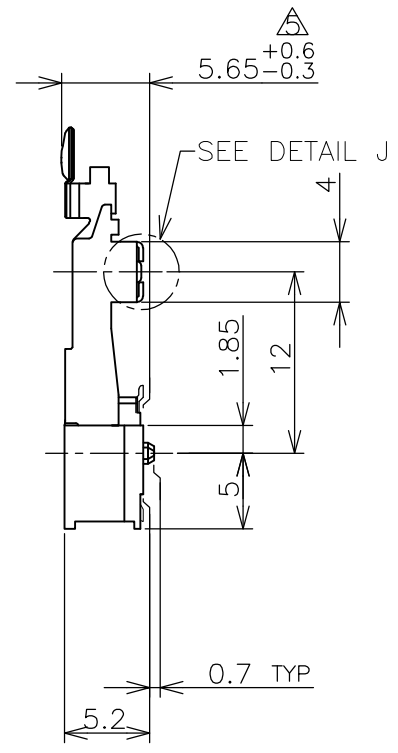
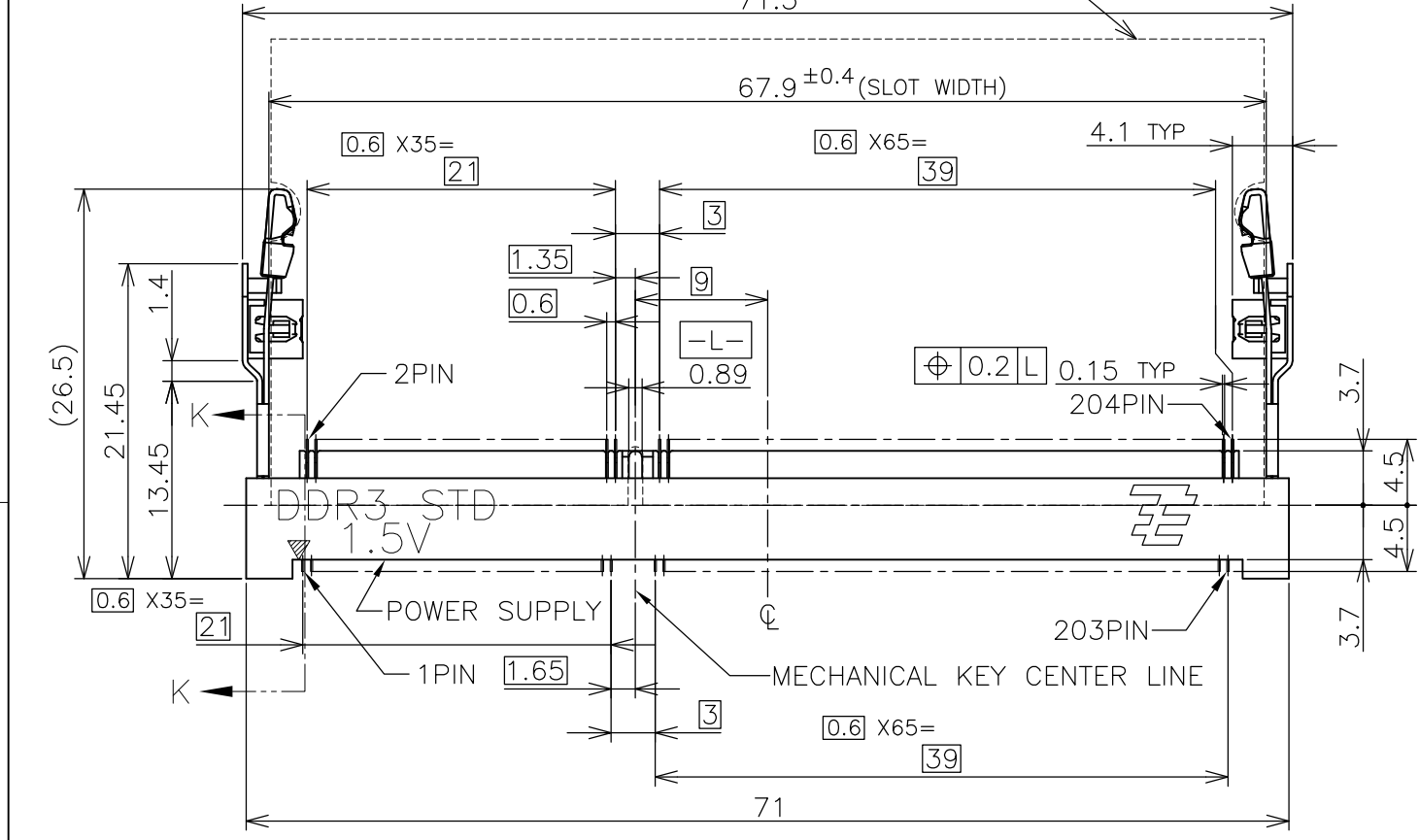

(APPLIED TO SHEET 1-3)

- MATERIAL ; HOUSING: HIGH TEMPERATURE THERMO PLASTIC UL94V-0
 COLOR: BLACK
 CONTACT: COPPER ARROY
 LOCK LEVER: STAINLESS STEEL
 PEG: COPPER ARROY
 - 2-1. FINISH ; CONTACT AREA: GOLD FLASH ALL OVER NICKEL.
 SOLDERING AREA: GOLD FLASH PLATING
 PEG: TIN PLATING
 - 2-2. FINISH ; CONTACT AREA: 0.000254MIN GOLD ALL OVER NICKEL.
 SOLDERING AREA: GOLD FLASH PLATING
 PEG: TIN PLATING
 - 2-3. FINISH ; CONTACT AREA: 0.00076MIN GOLD ALL OVER NICKEL.
 SOLDERING AREA: GOLD FLASH PLATING
 PEG: TIN PLATING
- △ COPLANARITY: 0.1 MAX. (BEFORE SOLDERING)
 △ THE FLOATING VALUE BY SOLDERING IS NOT INCLUDED.
 △ NOT MATING CONDITION.
6. IF THE MODULE DOESN'T INSERT AND LOCK IN THE LATCH SMOOTHLY, OPEN WIDE BOTH LATCHES BY MANUAL. AND THE MODULE MUST BE INSERTED AND LOCKED IN THE LATCH.

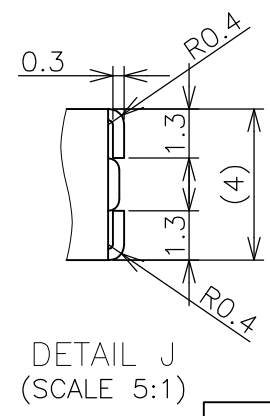
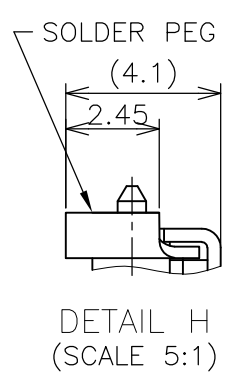
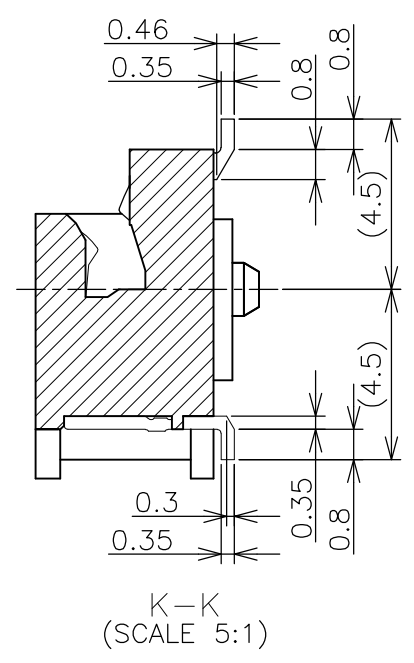

GENERAL TOLERANCE
 10≥:±0.2
 30≥ >10:±0.25
 100≥ >30:±0.3
 ANGLES:±3°

THIS DRAWING IS A CONTROLLED DOCUMENT.		DWN T.FUMIKURA 18SEP2007	TE Connectivity		
DIMENSIONS: MM		CHK K.IKEGAMI 18SEP2007			
TOLERANCES UNLESS OTHERWISE SPECIFIED:		APVD K.IKEGAMI 18SEP2007	NAME		
0 PLC ± 1 PLC ± 2 PLC ± 3 PLC ± 4 PLC ± ANGLES ± FINISH ±		PRODUCT SPEC	DDR3 SODIMM SOCKET		
MATERIAL		APPLICATION SPEC	0.6mm PITCH 204POS		
		WEIGHT 4.4g	5.2mm HEIGHT STANDARD TYPE		
		CUSTOMER DRAWING	SIZE A3	CAGE CODE 00779	DRAWING NO C-2013289
			RESTRICTED TO	SCALE 2:1	SHEET 1 OF 6
				REV C	

4

3

2

1

THIS DRAWING IS UNPUBLISHED.

RELEASED FOR PUBLICATION SEP , 2007.

© COPYRIGHT 2007 By -

ALL RIGHTS RESERVED.

LOC	DIST	REVISIONS					
J	/	P	LTR	DESCRIPTION	DATE	DWN	APVD
		-		SEE SHEET 1	-	-	-

AVAILABLE	ENBOSS (SEE SHEET 6)	WITH BOSS	BLACK	NOTE 2-3	1.5V	204	2-2013289-3
AVAILABLE	ENBOSS (SEE SHEET 6)	WITH BOSS	BLACK	NOTE 2-2	1.5V	204	2-2013289-2
AVAILABLE	ENBOSS (SEE SHEET 6)	WITH BOSS	BLACK	NOTE 2-1	1.5V	204	2-2013289-1
AVAILABLE	SEMI-HARD TRAY (SEE SHEET 5)	WITH BOSS	BLACK	NOTE 2-3	1.5V	204	2013289-3
AVAILABLE	SEMI-HARD TRAY (SEE SHEET 5)	WITH BOSS	BLACK	NOTE 2-2	1.5V	204	2013289-2
AVAILABLE	SEMI-HARD TRAY (SEE SHEET 5)	WITH BOSS	BLACK	NOTE 2-1	1.5V	204	2013289-1
TOOLING STATUS	PACKAGING TYPE	BOSS TYPE	HOUSING COLOR	FINISH	POWER SUPPLY	POS	PART NO.

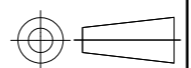
THIS DRAWING IS A CONTROLLED DOCUMENT.		DWN	 TE Connectivity			
DIMENSIONS: MM		CHK				
		APVD				
TOLERANCES UNLESS OTHERWISE SPECIFIED: 0 PLC ± 1 PLC ± 2 PLC ± 3 PLC ± 4 PLC ± ANGLES ±		NAME				
MATERIAL		PRODUCT SPEC	DDR3 SODIMM SOCKET 0.6mm PITCH 204POS 5.2mm HEIGHT STANDARD TYPE			
		APPLICATION SPEC	SIZE	CAGE CODE	DRAWING NO	RESTRICTED TO
		WEIGHT	A3	00779	C-2013289	-
CUSTOMER DRAWING			SCALE	SHEET	REV	
			2:1	2 OF 6	C	

P	LTR	DESCRIPTION	DATE	DWN	APVD
-	-	SEE SHEET 1	-	-	-

REFERENCE P.C.BOARD PATTERN LAYOUT (CONNECTOR MOUNTING SIDE)

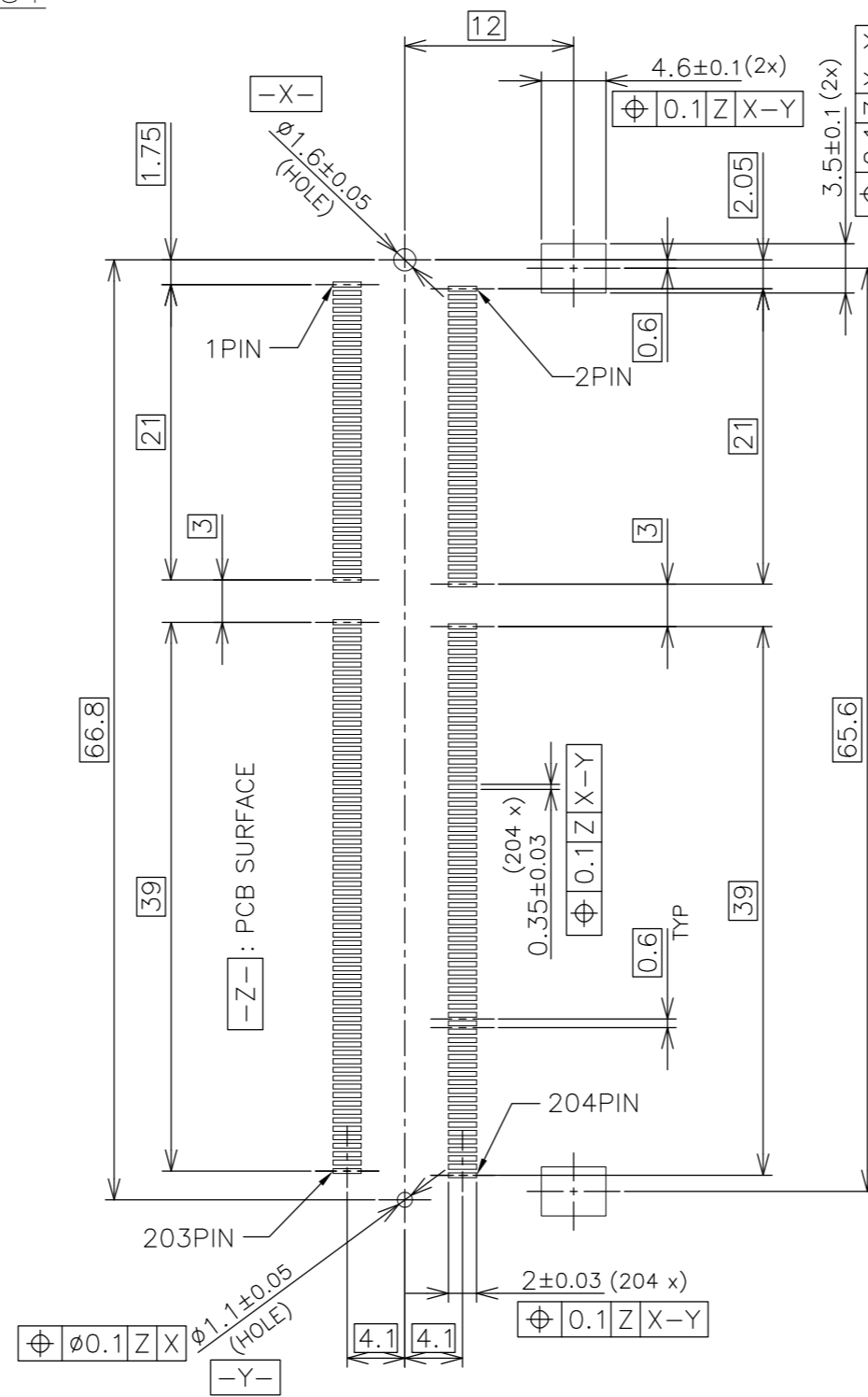

STD TYPE

THIS DRAWING IS A CONTROLLED DOCUMENT.		DWN		STE TE Connectivity	
DIMENSIONS: MM		CHK			
		TOLERANCES UNLESS OTHERWISE SPECIFIED:		NAME	
		0 PLC ± 1 PLC ± 2 PLC ± 3 PLC ± 4 PLC ± ANGLES ± FINISH		DDR3 SODIMM SOCKET 0.6mm PITCH 204POS 5.2mm HEIGHT STANDARD TYPE	
MATERIAL		APVD		SIZE	RESTRICTED TO
		PRODUCT SPEC		CAGE CODE	
		APPLICATION SPEC		DRAWING NO	
		WEIGHT		A300779	C-2013289
		CUSTOMER DRAWING		SCALE	SHEET
				2:1	3 of 6
				REV	C

LOC	DIST
J	/

REVISIONS

P	LTR	DESCRIPTION	DATE	DWN	APVD
-	-	SEE SHEET 1	-	-	-

REFERENCE MATING P.C.B CONFIGURATION

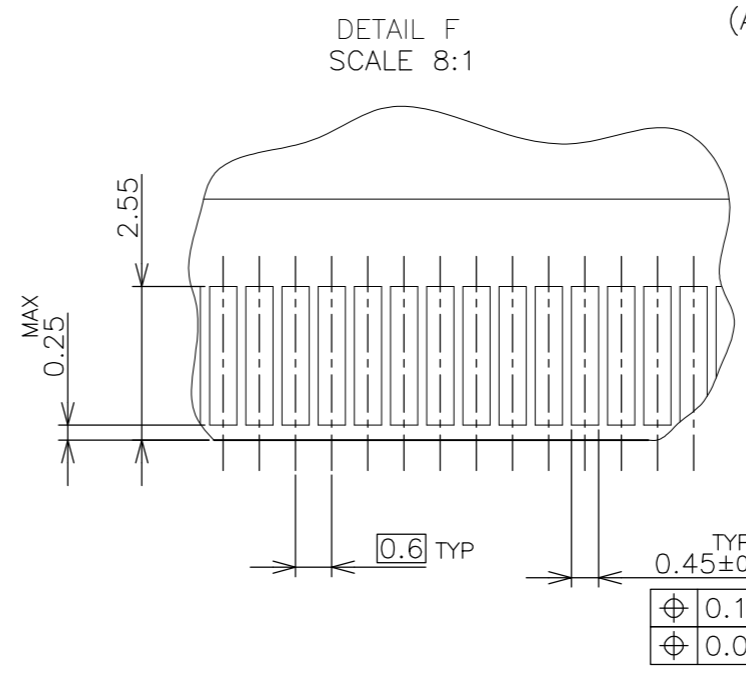
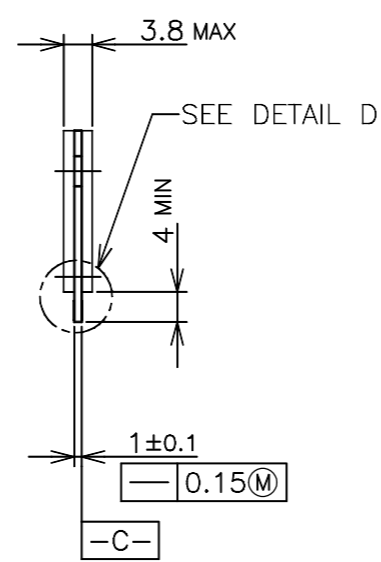
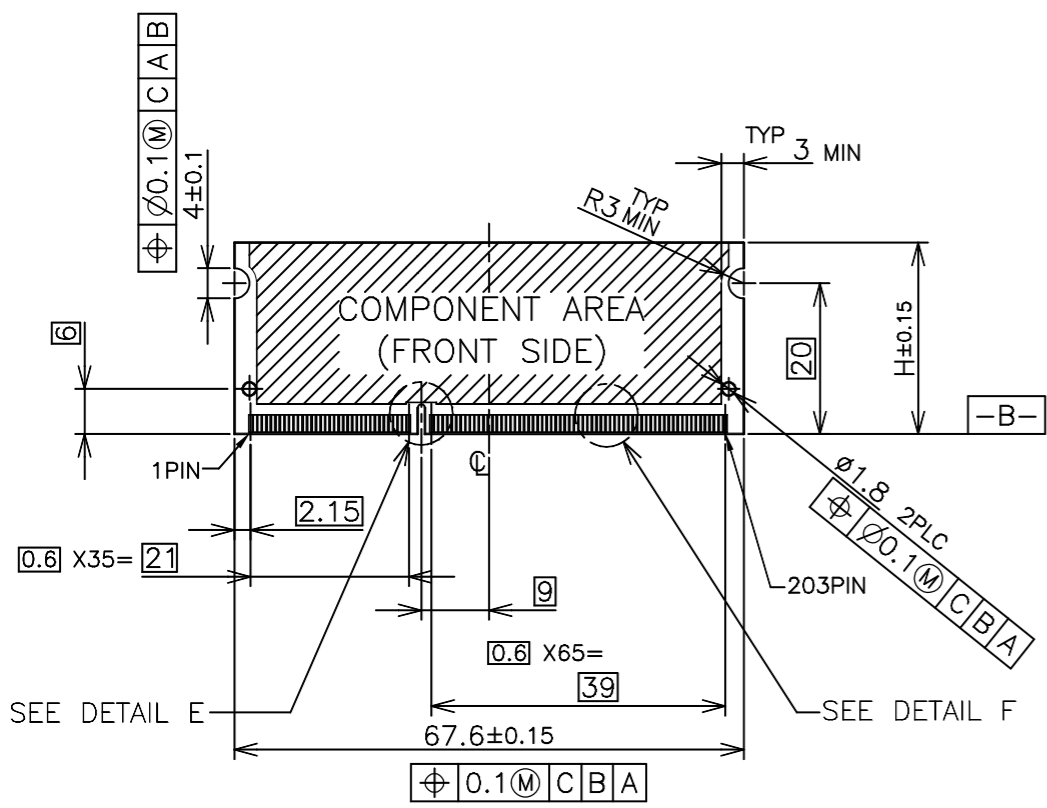

- (APPLIED TO SHEET 4)
1. TOLERANCES ON ALL DIMENSIONS ± 0.15 UNLESS OTHERWISE SPECIFIED.
 2. P.C. BOARD THICKNESS APPLIES ACROSS TABS AND INCLUDES PLATING AND/OR METALIZATION.
 3. FINISH OF PAD : GOLD PLATING 0.00076 MIN. OVER Ni PLATING 0.002MIN.
- NO BURR
 CHAMFER 0.25 MAX x 45° IF EXIST.

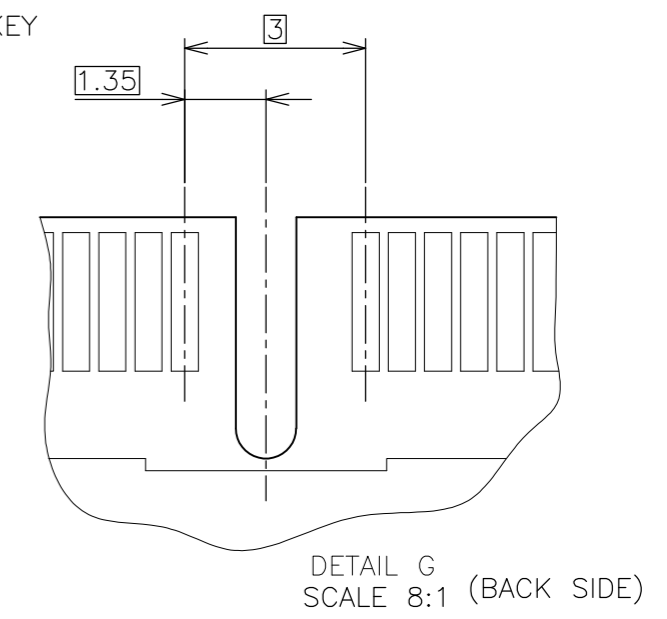
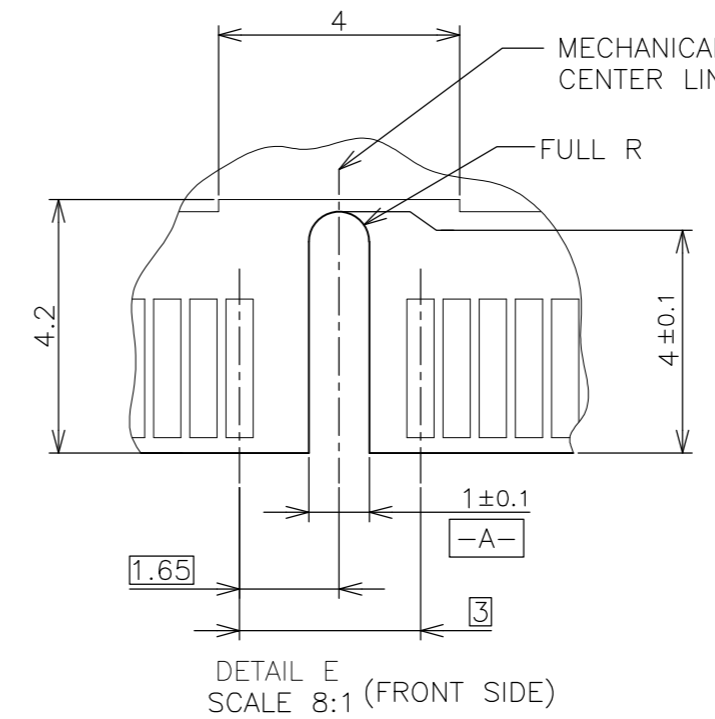
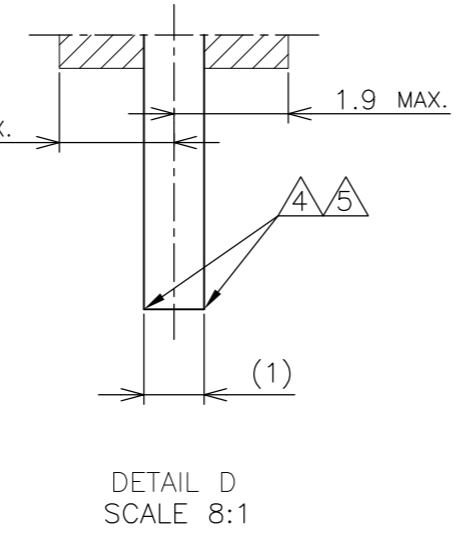
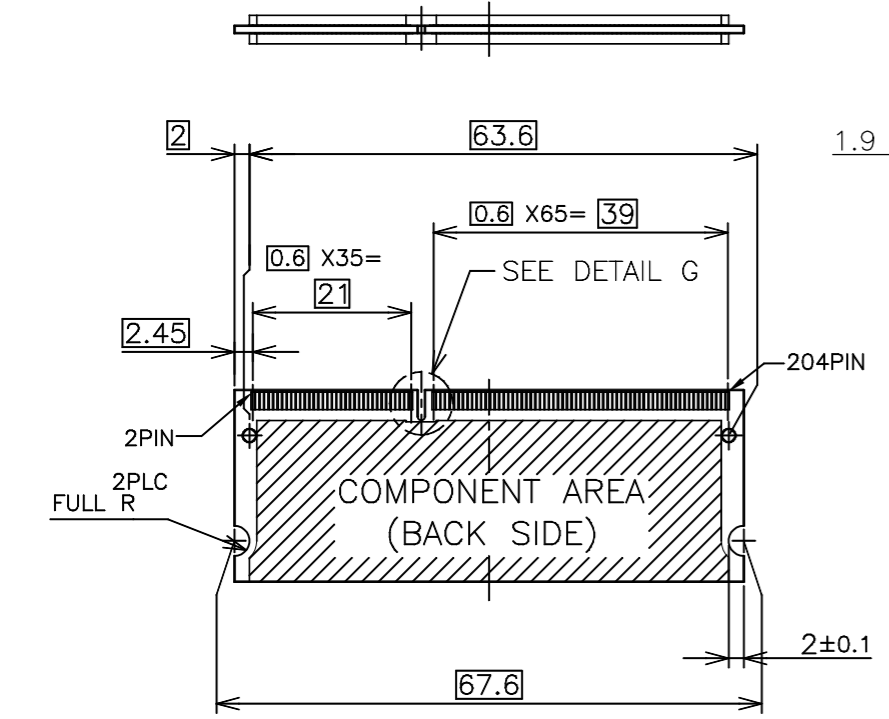

30	CA
31.75	BA
25.4	AA
H	SDRAM VARIATIONS

THIS DRAWING IS A CONTROLLED DOCUMENT.		DWN	TE Connectivity NAME DDR3 SODIMM SOCKET 0.6mm PITCH 204POS 5.2mm HEIGHT STANDARD TYPE				
DIMENSIONS: MM		CHK					
		APVD					
TOLERANCES UNLESS OTHERWISE SPECIFIED: 0 PLC ± 1 PLC ± 2 PLC ± 3 PLC ± 4 PLC ± ANGLES ± MATERIAL FINISH ±		PRODUCT SPEC					
MATERIAL		APVD	APPLICATION SPEC	SIZE	CAGE CODE	DRAWING NO	RESTRICTED TO
		WEIGHT	A300779		C-2013289	-	
CUSTOMER DRAWING			SCALE	2:1	SHEET	4 OF 6	REV
							C

THIS DRAWING IS UNPUBLISHED. RELEASED FOR PUBLICATION SEP , 2007.
 © COPYRIGHT 2007 By - ALL RIGHTS RESERVED.

LOC	DIST	REVISIONS					
		P	LTR	DESCRIPTION	DATE	DWN	APVD
J	/	-	-	SEE SHEET 1	-	-	-

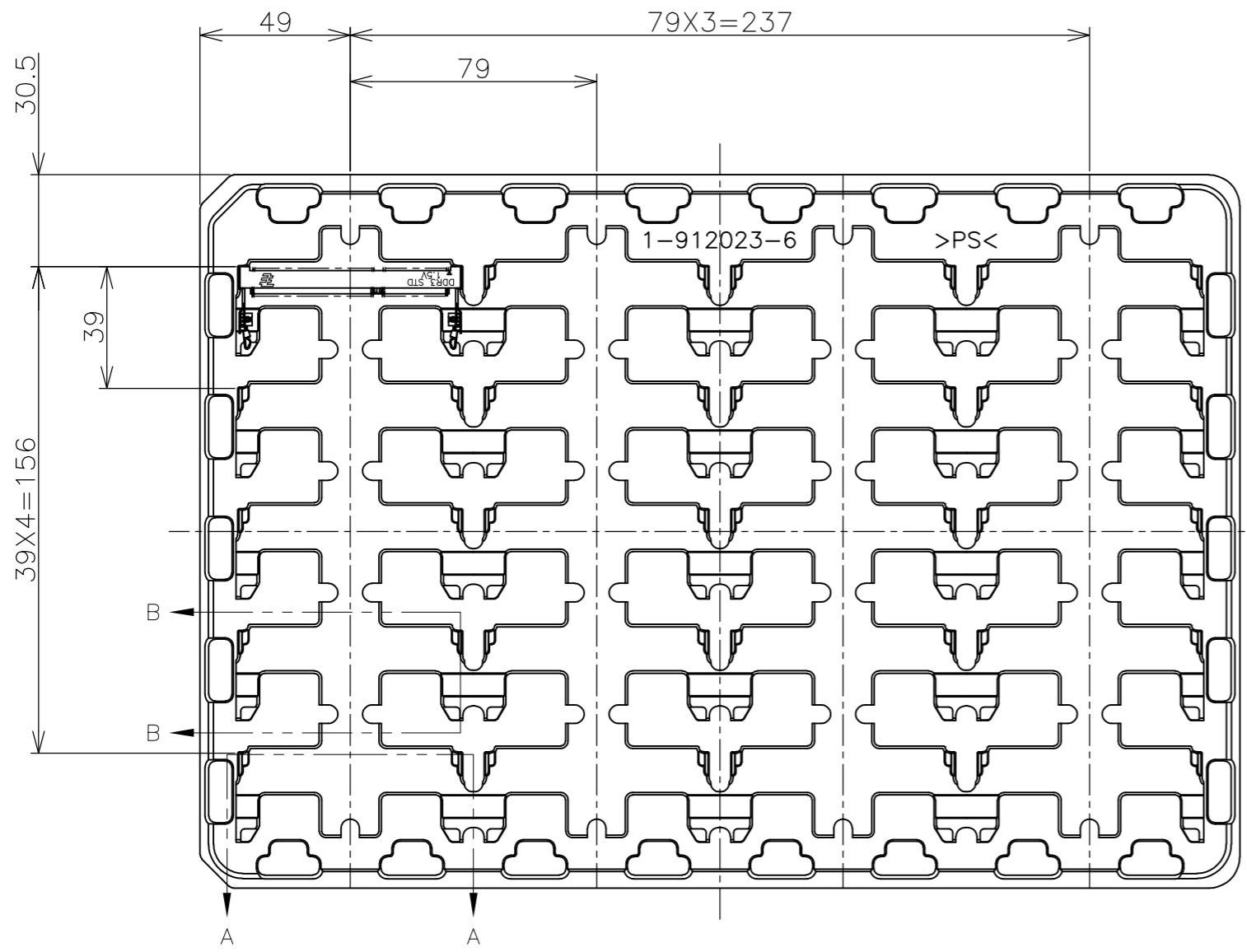

- (APPLIED TO SHEET 5)
1. THE DIRECTION OF EACH CONNECTOR ON A TRAY IS REFERRED TO THIS DRAWING.
 2. GENERAL TOLERANCE: ± 0.5 , $\pm 3'$

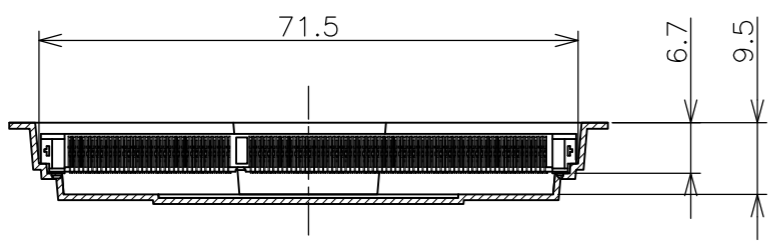
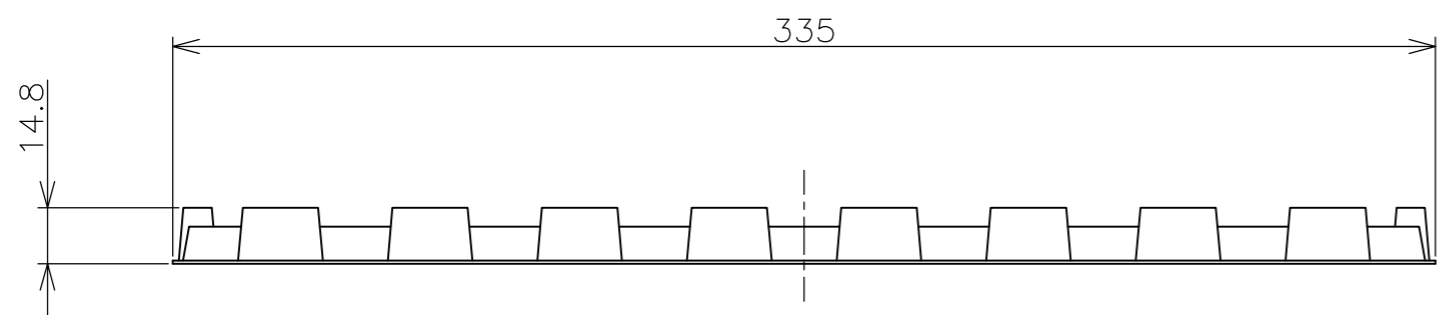
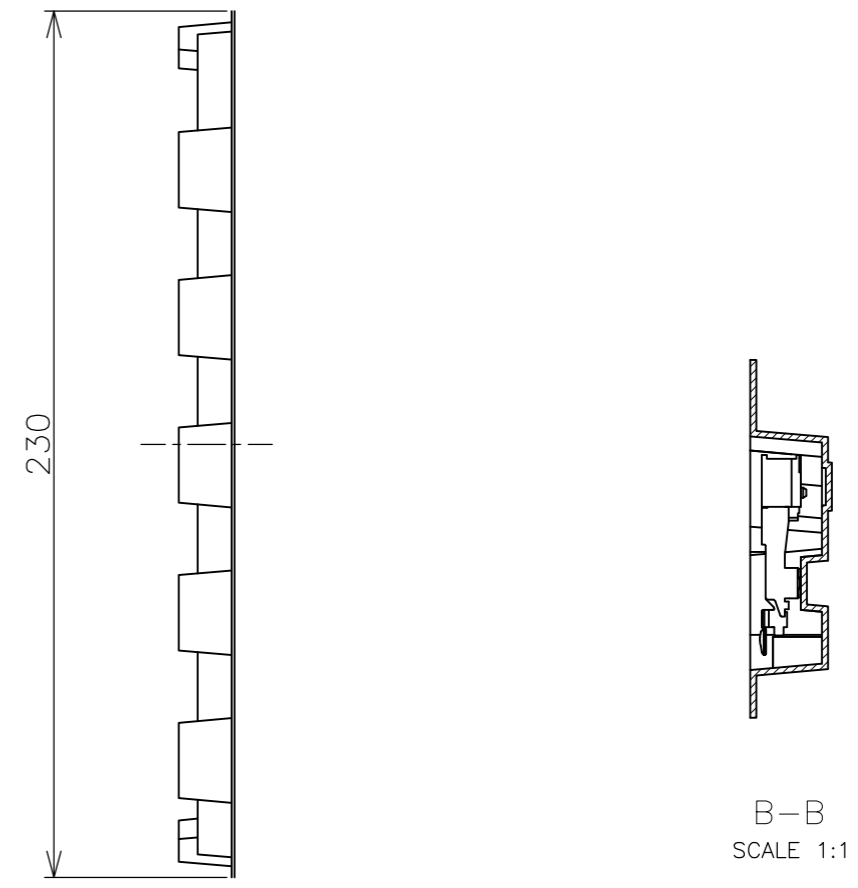

240EA	20EA	*-2013289-*
QTY/BOX	QTY/TRAY	PART NO.

THIS DRAWING IS A CONTROLLED DOCUMENT.		DWN		TE Connectivity NAME DDR3 SODIMM SOCKET 0.6mm PITCH 204POS 5.2mm HEIGHT STANDARD TYPE			
DIMENSIONS: MM		CHK					
TOLERANCES UNLESS OTHERWISE SPECIFIED:		APVD					
0 PLC ± 0.5 1 PLC ± 0.5 2 PLC ± 0.5 3 PLC ± 0.5 4 PLC ± 0.5 ANGLES $\pm 3'$		PRODUCT SPEC					
MATERIAL		FINISH		APPLICATION SPEC			
		WEIGHT		SIZE	CAGE CODE	DRAWING NO	RESTRICTED TO
				A3	00779	C-2013289	-
CUSTOMER DRAWING				SCALE	SHEET	REV	
				1:2	5 of 6	C	

THIS DRAWING IS UNPUBLISHED. RELEASED FOR PUBLICATION SEP ,2007.
 © COPYRIGHT 2007 By - ALL RIGHTS RESERVED.

LOC		DIST		REVISIONS				
P	LTR	DESCRIPTION			DATE	DWN	APVD	
	-	SEE SHEET 1			-	-	-	

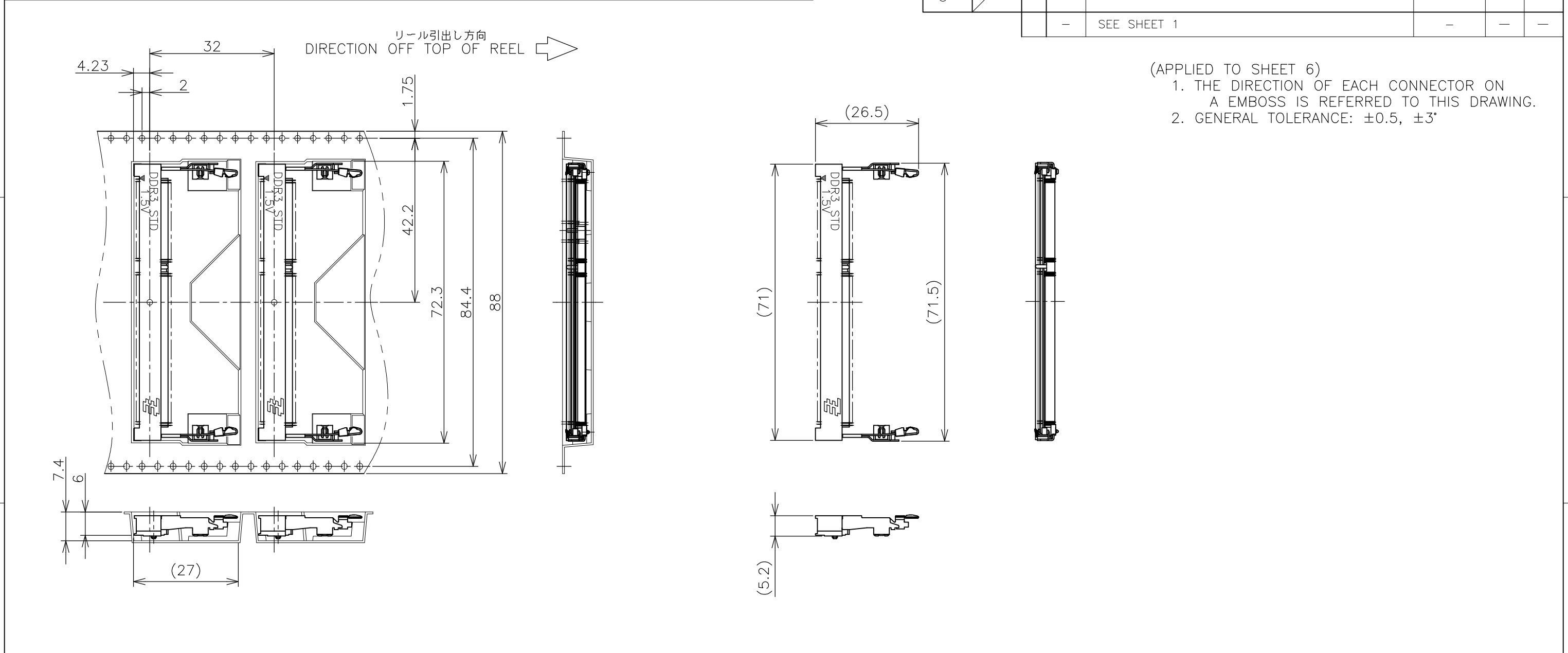

(APPLIED TO SHEET 6)
 1. THE DIRECTION OF EACH CONNECTOR ON A EMBOSS IS REFERRED TO THIS DRAWING.
 2. GENERAL TOLERANCE: ±0.5, ±3°

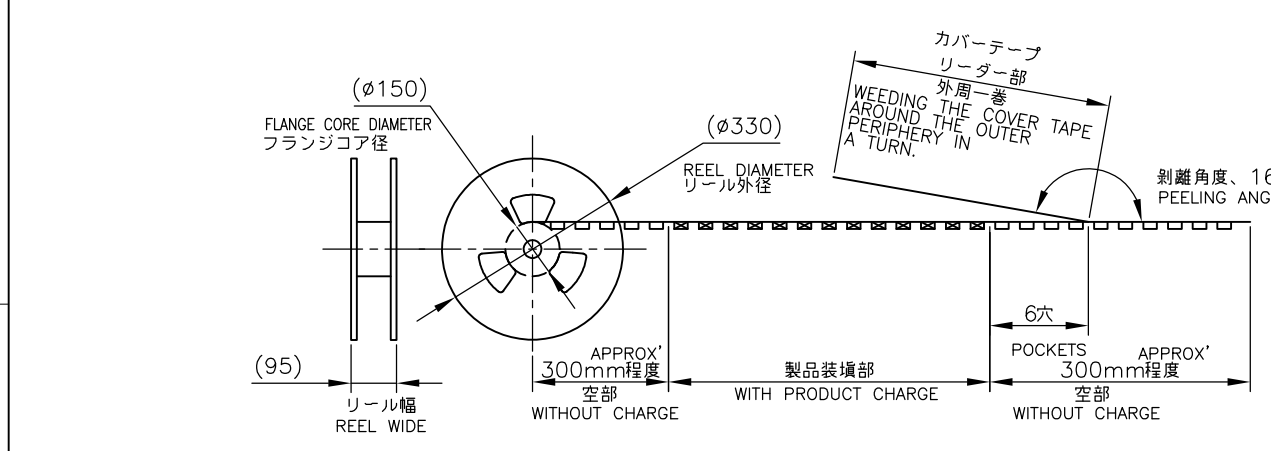

FREE SCALE

THIS DRAWING IS A CONTROLLED DOCUMENT.		DWN		TE Connectivity NAME DDR3 SODIMM SOCKET 0.6mm PITCH 204POS 5.2mm HEIGHT STANDARD TYPE	
DIMENSIONS: MM		CHK			
TOLERANCES UNLESS OTHERWISE SPECIFIED:		APVD			
MATERIAL		PRODUCT SPEC			
FINISH		APPLICATION SPEC		SIZE	
		WEIGHT		CAGE CODE	
		CUSTOMER DRAWING		DRAWING NO	
				RESTRICTED TO	
				A3 00779 C-2013289	
				SCALE 1:2	
				SHEET 6 OF 6	
				REV C	

Mouser Electronics

Authorized Distributor

Click to View Pricing, Inventory, Delivery & Lifecycle Information:

[TE Connectivity:](#)

[2013289-2](#)