

Oct.1.2020 Copyright 2020 HIROSE ELECTRIC CO., LTD. All Rights Reserved.  
In case of consideration for using Automotive equipment / device which demand high reliability, kindly contact our sales window correspondents.

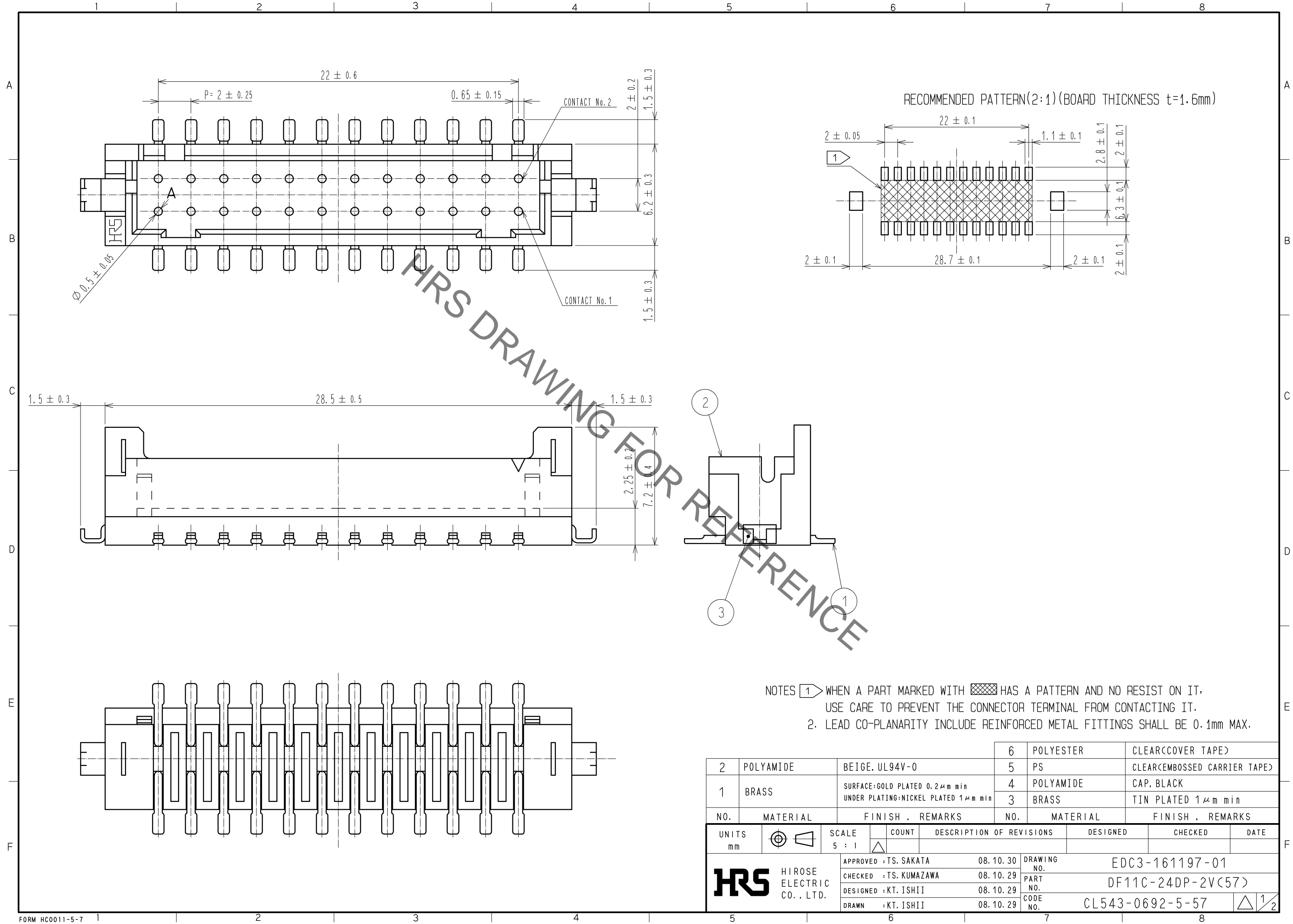

HRS DRAWING FOR REFERENCE

- NOTES 1. WHEN A PART MARKED WITH HAS A PATTERN AND NO RESIST ON IT, USE CARE TO PREVENT THE CONNECTOR TERMINAL FROM CONTACTING IT.  
2. LEAD CO-PLANARITY INCLUDE REINFORCED METAL FITTINGS SHALL BE 0.1mm MAX.

NO.	MATERIAL	FINISH . REMARKS	NO.	MATERIAL	FINISH . REMARKS
2	POLYAMIDE	BEIGE. UL94V-0	6	POLYESTER	CLEAR(COVER TAPE)
1	BRASS	SURFACE:GOLD PLATED 0.2μm min UNDER PLATING:NICKEL PLATED 1μm min	5	PS	CLEAR(EMBOSSED CARRIER TAPE)
			4	POLYAMIDE	CAP. BLACK
			3	BRASS	TIN PLATED 1μm min

UNITS	SCALE	COUNT	DESCRIPTION OF REVISIONS	DESIGNED	CHECKED	DATE
mm	5 : 1	△				
APPROVED : TS. SAKATA			08.10.30	DRAWING NO. EDC3-161197-01		
CHECKED : TS. KUMAZAWA			08.10.29	PART NO. DF11C-24DP-2V(57)		
DESIGNED : KT. ISHII			08.10.29	CODE NO. CL543-0692-5-57		
DRAWN : KT. ISHII			08.10.29	△ 1/2		

Oct.1.2020 Copyright 2020 HIROSE ELECTRIC CO., LTD. All Rights Reserved.  
 In case of consideration for using Automotive equipment / device which demand high reliability, kindly contact our sales window correspondents.

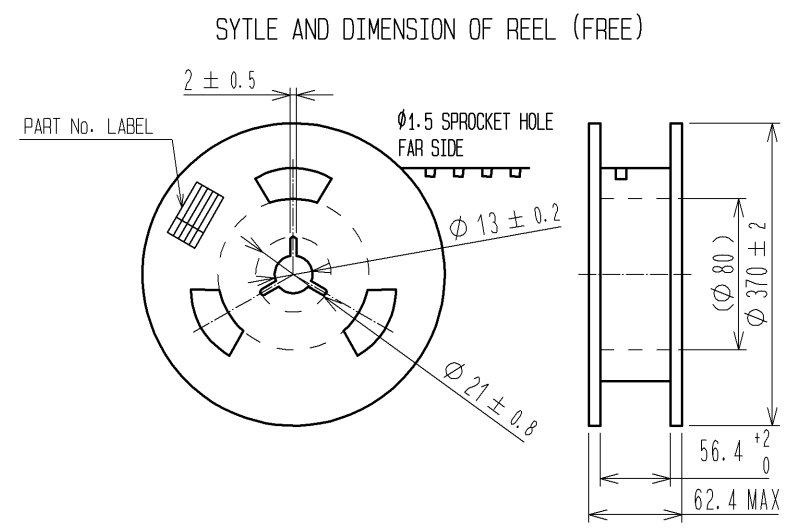
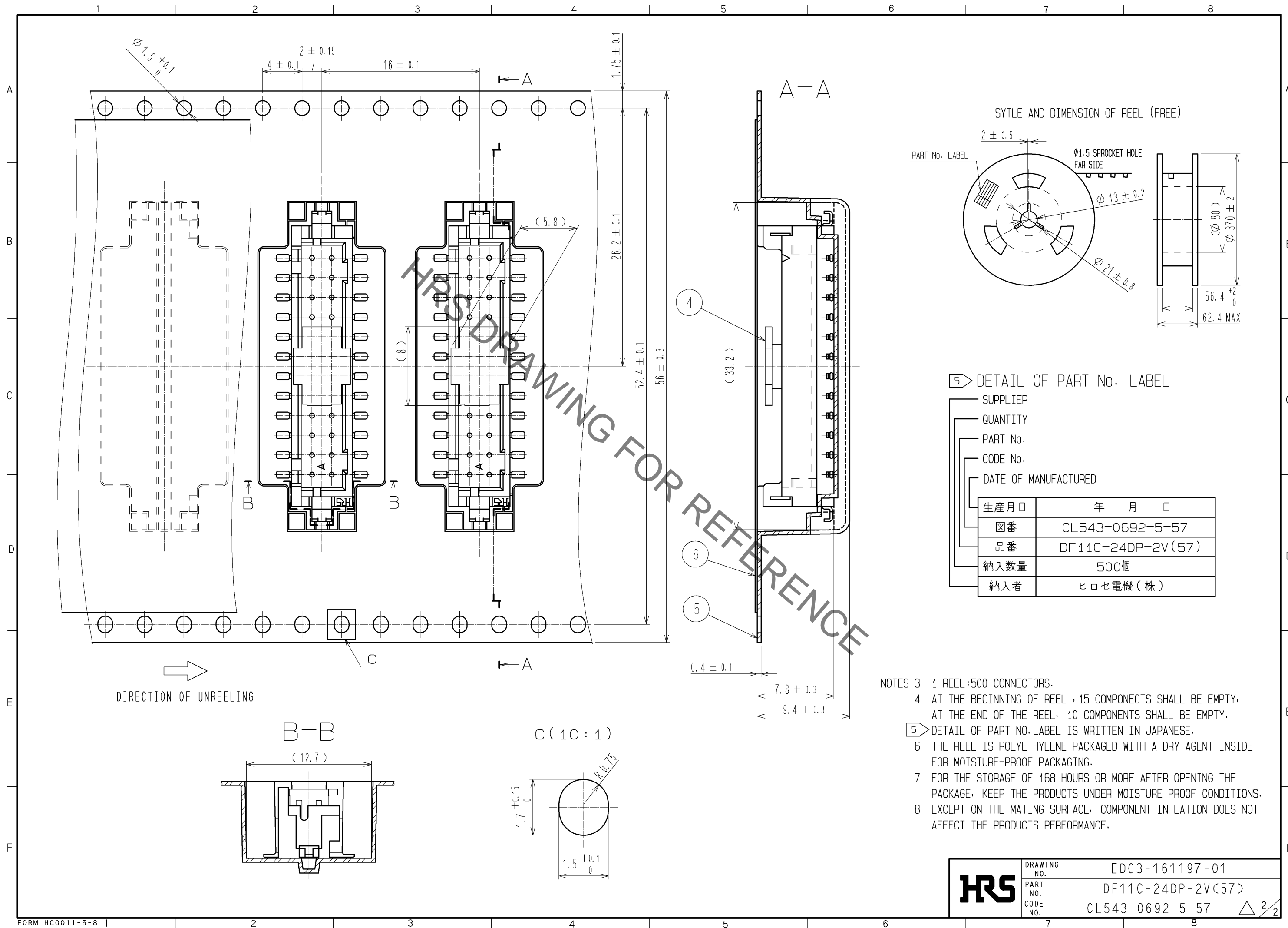

5) DETAIL OF PART No. LABEL

- SUPPLIER
- QUANTITY
- PART No.
- CODE No.
- DATE OF MANUFACTURED

生産月日	年 月 日
箱番	CL543-0692-5-57
品番	DF11C-24DP-2V(57)
納入数量	500個
納入者	ヒロセ電機(株)

- NOTES
- 1 REEL:500 CONNECTORS.
  - 4 AT THE BEGINNING OF REEL, 15 COMPONENTS SHALL BE EMPTY. AT THE END OF THE REEL, 10 COMPONENTS SHALL BE EMPTY.
  - 5) DETAIL OF PART No. LABEL IS WRITTEN IN JAPANESE.
  - 6 THE REEL IS POLYETHYLENE PACKAGED WITH A DRY AGENT INSIDE FOR MOISTURE-PROOF PACKAGING.
  - 7 FOR THE STORAGE OF 168 HOURS OR MORE AFTER OPENING THE PACKAGE, KEEP THE PRODUCTS UNDER MOISTURE PROOF CONDITIONS.
  - 8 EXCEPT ON THE MATING SURFACE, COMPONENT INFLATION DOES NOT AFFECT THE PRODUCTS PERFORMANCE.

<b>HRS</b>	DRAWING NO.	EDC3-161197-01
	PART NO.	DF11C-24DP-2V(57)
	CODE NO.	CL543-0692-5-57
		△ 2/2