

REVISIONS			
REV	DESCRIPTION	DATE	APPROVED
A	INITIAL RELEASE	01/26/11	A.D.M.

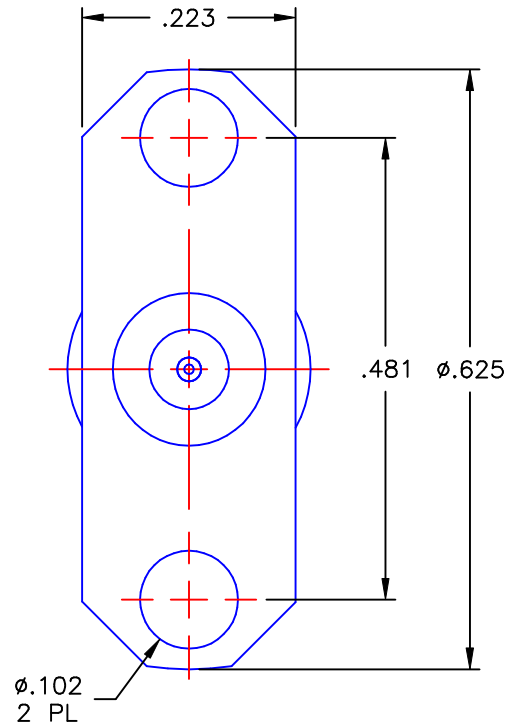
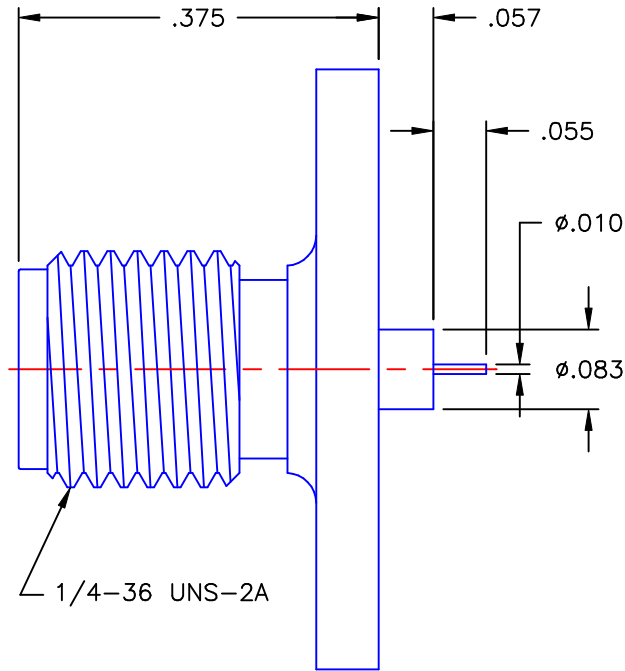

NOTES:

MATERIALS:

1. BODY = STAINLESS STEEL PER ASTM A582, ALLOY 303, CONDITION "A".
2. INSULATOR = VIRGIN WHITE TEFLON PER ASTM D1710, GRADE 1, TYPE I, CLASS "B".
3. CONTACT = BERYLLIUM COPPER PER ASTM B196, ALLOY C17300, TEMPER TD04.

FINISHES:

1. BODY = GOLD PLATE PER MIL-G-45204, TYPE II, CLASS 0, GRADE C, OVER .000050 TO .00010 STRESS FREE NICKEL PER QQ-N-290.
2. CONTACT = GOLD PLATE PER MIL-G-45204, TYPE II, CLASS 1, GRADE C, OVER .00010 TO .00020 STRESS FREE SULFAMATE NICKEL PER QQ-N-290.

UNLESS OTHERWISE SPECIFIED DIMENSIONS ARE IN INCHES TOLERANCES ON	DWN: A.D.M.	DATE: 01/26/11	 Property of Radial This document cannot be reproduced or communicated to a third party without prior written permission of RADIAL.				
	CHKD: D.N.	DATE: 01/26/11					
	DECIMAL	ANGLE	APVD: J.M.	DATE: 01/26/11	SMA STRAIGHT JACK 2 HOLE FLANGE MOUNT RECEPTACLE		
REFERENCE:		MATERIALS & FINISHES: SEE NOTES		SIZE: A			FSCM NO.: 19505
ORIGINATOR: A.D.M. DATE: 01/26/11		SCALE: 5:1		THIRD ANGLE PROJECTION		SHEET 1 OF 1	

9308-1113-003

Mouser Electronics

Authorized Distributor

Click to View Pricing, Inventory, Delivery & Lifecycle Information:

Radial:

[9308-1113-003](#)