

MAX2750AUA

2.4GHz Monolithic Voltage-Controlled Oscillator

General Description

The MAX2750AUA is a self-contained voltage-controlled oscillator (VCO) intended for use over the 2370MHz to 2470MHz frequency range. The IC combines a fully integrated oscillator and output buffer in a miniature 8-pin μ MAX[®] package.

The inductor and varactor elements of the tank are integrated on-chip, greatly simplifying application of the part. The only required external components are a couple of supply bypass capacitors. The IC provides direct connection to the VCO tuning voltage input and the VCO buffer output. The tuning voltage input range is +0.4V to +2.4V, and the oscillator frequency tuning range is factory adjusted to provide guaranteed limits. The output signal is buffered by an amplifier stage (internally matched to 50 Ω) to provide higher output power and isolate the device from load impedance variations.

The MAX2750AUA operates over a +2.7V to +5.5V supply voltage range. Internal regulation of the oscillator supply voltage eliminates the need for an external LDO regulator for the VCO. The IC also provides a digitally controlled shutdown mode to permit implementation of sophisticated power-supply management. In shutdown, the supply current is reduced to less than 2 μ A.

Applications

- 2.4GHz ISM Band

Features

- Guaranteed Frequency Tuning Range: 2370MHz to 2470MHz
- On-Chip Tank Circuit
- Internally Matched Output Buffer Amplifier
- Low-Current Shutdown Mode
- +2.7V to +5.5V Supply Voltage Range
- Miniature 8-Pin μ MAX Package
- -40°C to +125°C Temperature Range

Ordering Information

PART	TEMP RANGE	PIN-PACKAGE
MAX2750AUA+	-40°C to +125°C	8 μ MAX

+Denotes a lead(Pb)-free/RoHS-compliant package.

Pin Configuration appears at end of data sheet.

μ MAX is a registered trademark of Maxim Integrated Products, Inc.

Typical Operating Circuit

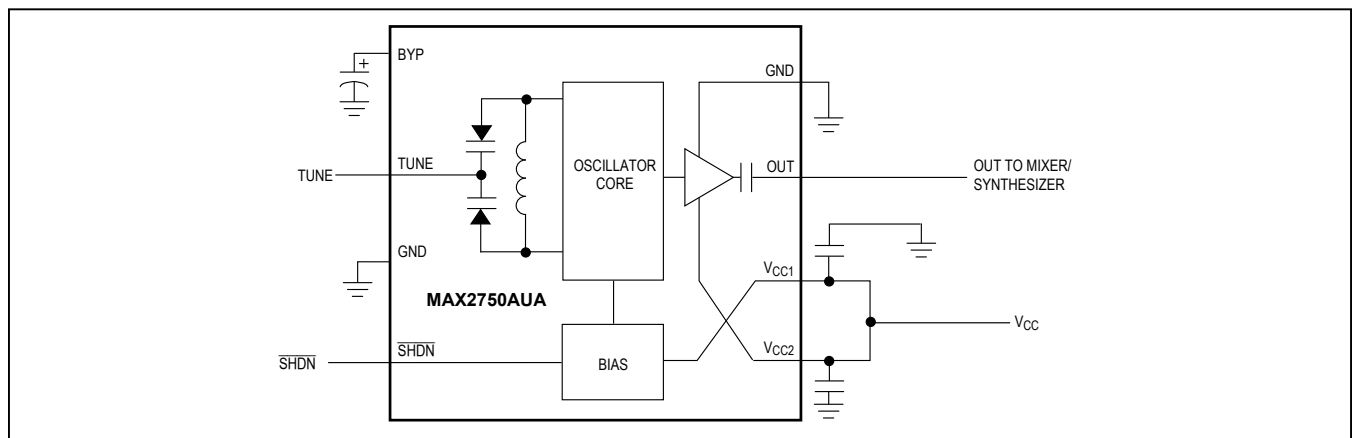

Absolute Maximum Ratings

V _{CC} to GND.....	-0.3V to +6V	Operating Temperature Range	-40°C to +125°C
TUNE, SHDN, BYP, OUT to GND.....	-0.3V to (V _{CC} + 0.3V)	Junction Temperature.....	+150°C
Continuous Power Dissipation (T _A = +70°C)		Storage Temperature Range	-65°C to +150°C
8-Pin μMAX (derate 5.7mW/°C above T _A = +70°C)....	457mW	Lead Temperature (soldering, 10s)	+300°C

Stresses beyond those listed under "Absolute Maximum Ratings" may cause permanent damage to the device. These are stress ratings only, and functional operation of the device at these or any other conditions beyond those indicated in the operational sections of the specifications is not implied. Exposure to absolute maximum rating conditions for extended periods may affect device reliability.

DC Electrical Characteristics

(V_{CC} = +2.7V to +5.5V, V_{TUNE} = +0.4V to +2.4V, V_{SHDN} ≤ +2V, OUT = connected to 50Ω load, T_A = -40°C to +125°C. Typical values are at V_{CC} = +3.0V, T_A = +25°C, unless otherwise noted.) (Note 1)

PARAMETER	CONDITIONS	MIN	TYP	MAX	UNITS
Supply Voltage		2.7		5.5	V
Supply Current	T _A = +25°C		11.3	14.4	mA
	T _A = -40°C to +125°C		16.0	21.0	
Shutdown Supply Current			2		μA
SHDN Input Voltage Low				0.6	V
SHDN Input Voltage High		2.0			V
SHDN Input Current Low	V _{SHDN} ≤ 0.6V	-2		+2	μA
SHDN Input Current High	V _{SHDN} ≥ 2.0V	-2		+2	μA
TUNE Input Current	0.4 ≤ V _{TUNE} ≤ 2.4V		20		nA

AC Electrical Characteristics

(MAX2750AUA EV kit, V_{CC} = +2.7V to +5.5V, V_{TUNE} = +0.4V to +2.4V, V_{SHDN} ≤ +2V, OUT = connected to 50Ω load, T_A = +25°C. Typical values are at V_{CC} = +3.0V, unless otherwise noted.) (Note 1)

PARAMETER	CONDITIONS	MIN	TYP	MAX	UNITS
Oscillator Guaranteed Frequency Limits	V _{TUNE} = +0.4V to +2.4V, T _A = -40°C to +125°C (Note1)	2370		2470	MHz
Phase Noise	f _{OFFSET} = 4MHz		-125		dBc/Hz
	Noise floor		-151		dBm/Hz
Tuning Gain (Note 2)	f _{OSC} = 2370MHz, +3V		140		MHz/V
	f _{OSC} = 2470MHz, +3V		90		
Output Power			-3		dBm
Return Loss			12		dB
Harmonics			-30		dBc
Load Pulling	VSWR = 2:1, all phases		4		MHz _{P-P}
Supply Pushing	V _{CC} stepped: +3.3V to +2.8V		1.3		MHz/V
Oscillator Turn-On Time	Exiting shutdown (Note 3)		8		μs
Oscillator Turn-Off Time	Entering shutdown (Note 4)		5		μs

Note 1: Minimum and maximum limits are guaranteed by production test at T_A = +25°C and T_A = +125°C. Minimum and maximum limits are guaranteed by design and characterization at T_A = -40°C.

Note 2: Tuning gain is measured at the oscillator's guaranteed frequency limits.

Note 3: Turn-on time to within 3dB of final output power

Note 4: Turn-off time to output power of -10dBm.

Typical Operating Characteristics

(Circuit of Figure 1, $V_{CC} = +3.0V$, $V_{TUNE} = +0.4V$ to $+2.4V$, $V_{SHDN} \leq 2V$, $T_A = +25^\circ C$, unless otherwise noted.)

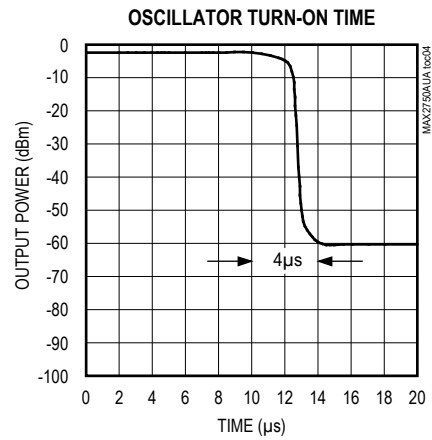
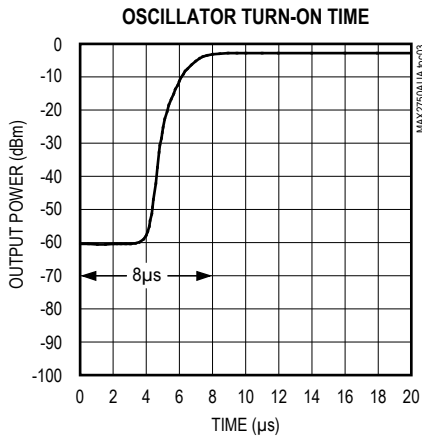
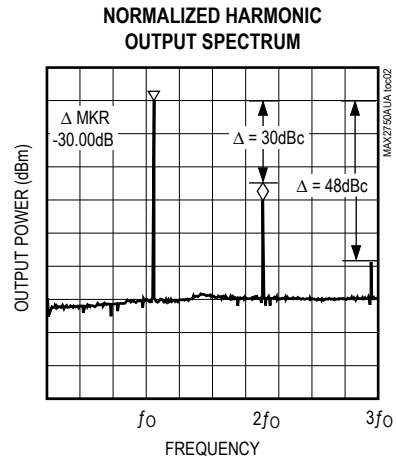
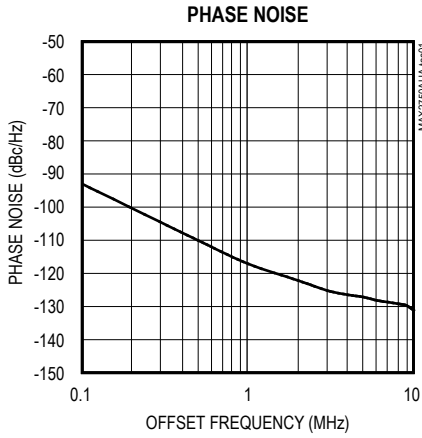

Pin Description

PIN	NAME	FUNCTION
1	BYP	VCO Bypass. Bypass with a 0.1μF capacitor to GND.
2	TUNE	Oscillator Frequency Tuning Voltage Input. High-impedance input with a voltage input range of +0.4V (low frequency) to +2.4V (high frequency).
3	GND	Ground Connection for Oscillator and Biasing. Requires a low-inductance connection to the circuit board ground plane.
4	SHDN	Shutdown Logic Input. A high-impedance input logic-level low disables the device and reduces supply current to less than 1.0μA. A logic-level high enables the device.
5	V _{CC1}	Bias and Oscillator DC Supply Voltage Connection. Bypass separately from pin 6 with a 220pF capacitor to GND for low noise and low spurious content performance from the oscillator.
6	V _{CC2}	Output Buffer DC Supply Voltage Connection. Bypass separately from pin 5 with a 220pF capacitor to GND for best high frequency performance.
7	OUT	Buffered Oscillator Output. Incorporates an internal DC-blocking capacitor. OUT is internally matched to 50Ω.
8	GND	Ground Connection for Output Buffer. Requires a low-inductance connection to the circuit board ground plane.

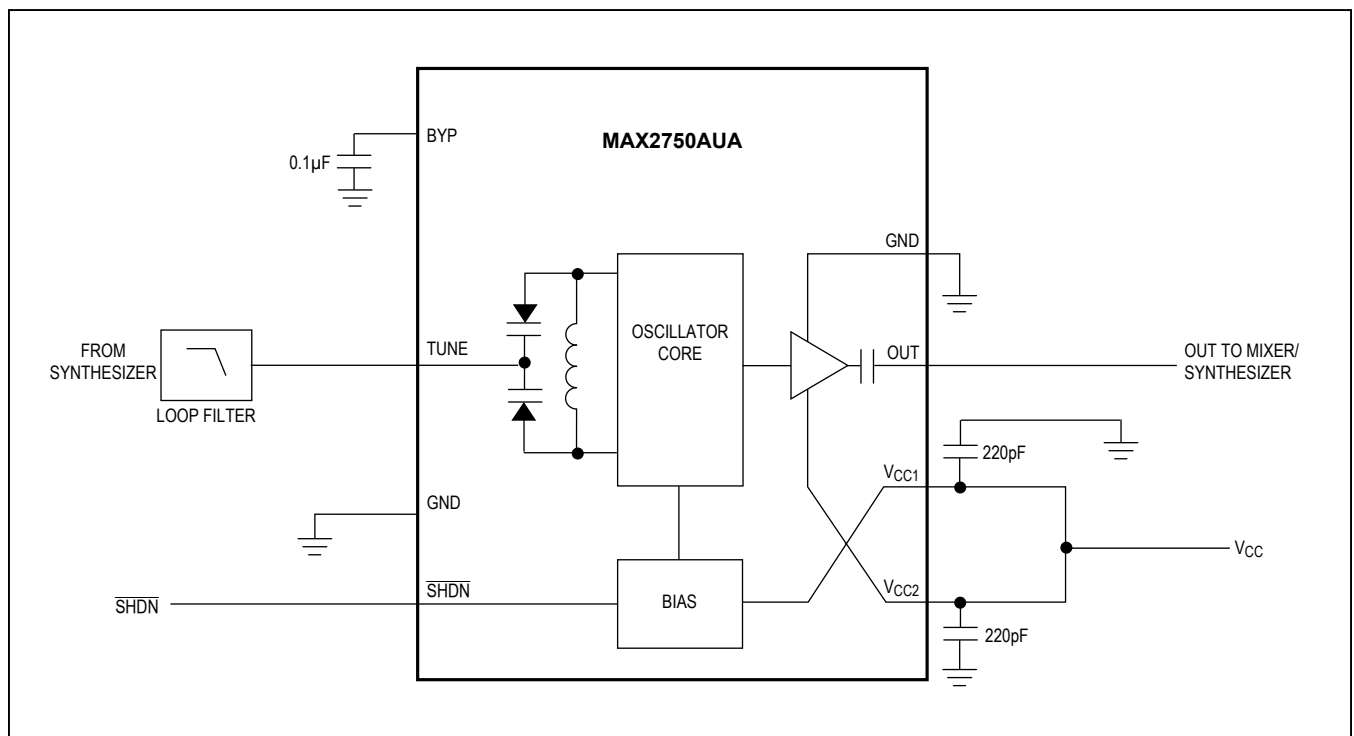

Figure 1. Typical Application Circuit

Detailed Description

Oscillator

The MAX2750AUA VCO is implemented as an LC oscillator topology, integrating all of the tank components on-chip. This fully monolithic approach provides an extremely easy-to-use VCO, equivalent to a VCO module. The frequency is controlled by a voltage applied to the TUNE pin, which is internally connected to the varactor. The VCO core uses a differential topology to provide a stable frequency versus supply voltage and improve the immunity to load variations. In addition, there is a buffer amplifier following the oscillator core to provide added isolation from load variations and to boost the output power.

Output Buffer

The oscillator signal from the core drives an output buffer amplifier. The amplifier is internally matched to 50Ω including an on-chip DC-blocking capacitor. No external DC-blocking capacitor is required, eliminating the need for any external components. The output amplifier has its own V_{CC} and GND pins to minimize load-pulling effects. The amplifier boosts the oscillator signal to a level suitable for driving most RF mixers.

Applications Information

Tune Input

The tuning input is typically connected to the output of the PLL loop filter. The loop filter provides an appropriately low-impedance source. The input may incorporate an extra RC filter stage to reduce high-frequency noise and spurious signals. Any excess noise on the tuning input is directly translated into FM noise, which can degrade the phase-noise performance of the oscillator. Therefore, it is important to minimize the noise introduced on the tuning input. A simple RC filter with low corner frequency is needed during testing to filter the noise present on the voltage source driving the tuning line.

Layout Issues

Always use controlled impedance lines (microstrip, coplanar waveguide, etc.) for high-frequency signals. Always place decoupling capacitors as close as possible to the V_{CC} pins; for long V_{CC} lines, it may be necessary to add additional decoupling capacitors located further from the device. Always provide a low-inductance path to ground, and keep GND vias as close as possible to the device. Thermal reliefs on GND pads are not recommended.

Pin Configuration

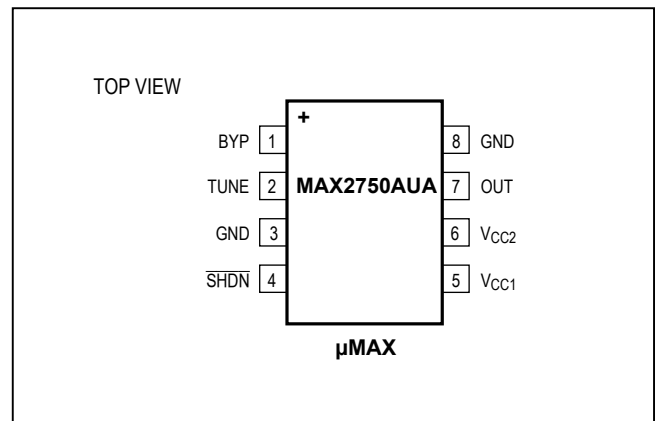

Package Information

For the latest package outline information and land patterns (footprints), go to www.maximintegrated.com/packages. Note that a "+", "#", or "-" in the package code indicates RoHS status only. Package drawings may show a different suffix character, but the drawing pertains to the package regardless of RoHS status.

PACKAGE TYPE	PACKAGE CODE	DOCUMENT NO.	LAND PATTERN NO.
8 μ SOP	U8+1	21-0036	90-0092

Revision History

REVISION NUMBER	REVISION DATE	DESCRIPTION	PAGES CHANGED
0	6/07	Initial release	—
1	4/15	Removed automotive reference from data sheet	1

For pricing, delivery, and ordering information, please contact Maxim Direct at 1-888-629-4642, or visit Maxim Integrated's website at www.maximintegrated.com.

Maxim Integrated cannot assume responsibility for use of any circuitry other than circuitry entirely embodied in a Maxim Integrated product. No circuit patent licenses are implied. Maxim Integrated reserves the right to change the circuitry and specifications without notice at any time. The parametric values (min and max limits) shown in the Electrical Characteristics table are guaranteed. Other parametric values quoted in this data sheet are provided for guidance.

Mouser Electronics

Authorized Distributor

Click to View Pricing, Inventory, Delivery & Lifecycle Information:

[Maxim Integrated:](#)

[MAX2750AUA+](#) [MAX2750AUA+T](#)