

Customer Information Sheet

DRAWING No.: M20-877XXXXR

IF IN DOUBT - ASK

©

NOT TO SCALE

THIRD ANGLE PROJECTION

ALL DIMENSIONS IN mm

RECOMMENDED PAD LAYOUT
(TOLERANCE = ± 0.05)

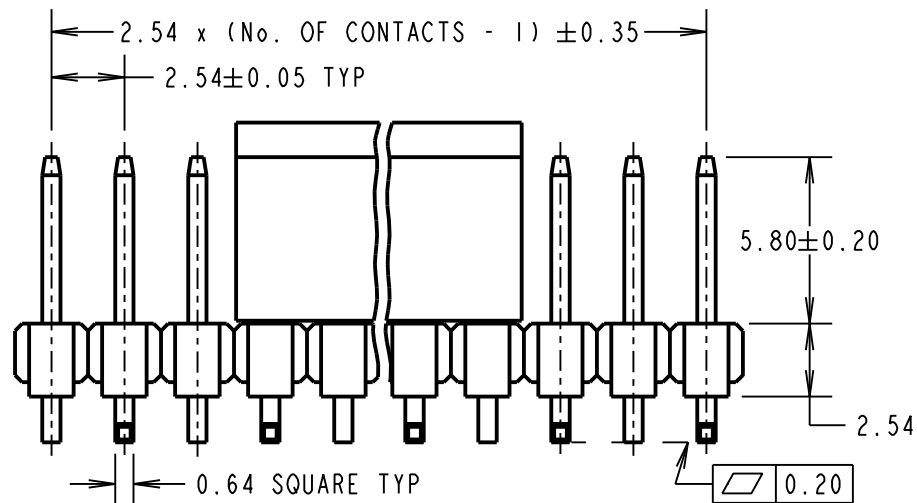
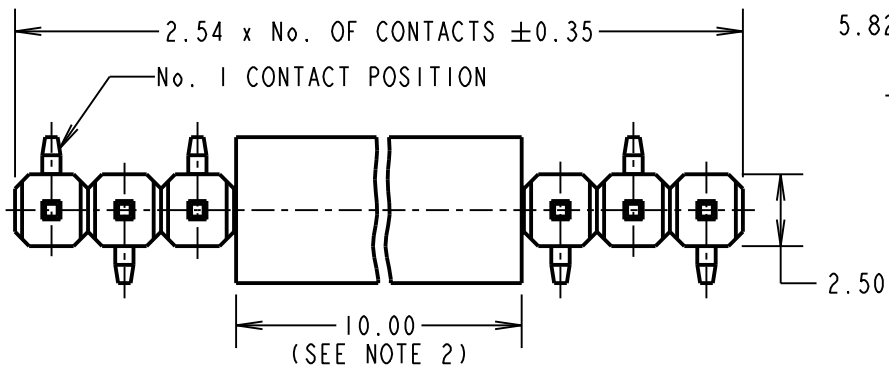
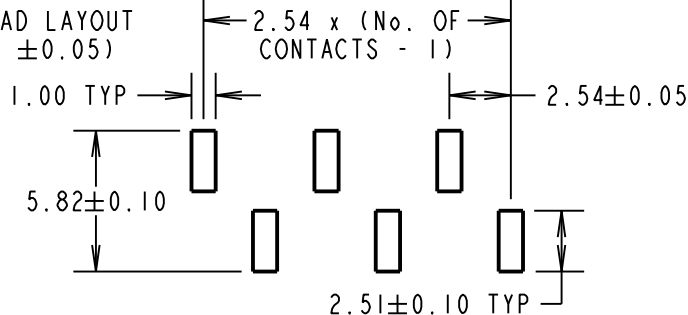

CONTACT TO CONTACT

ORDER CODE:
M20-877XXXXR

No. OF CONTACTS: _____
02, 03, 04, 05, 06,
08, 10, 15, 16, 19

FINISH: _____
42 = SELECTIVE GOLD + 100% TIN
46 = 100% TIN

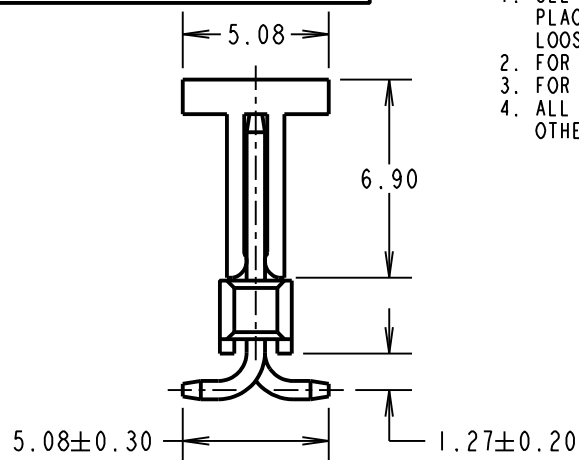

SPECIFICATION:

MATERIAL:
MOULDING = PA6T UL94V-0, BLACK
CONTACT = BRASS
FINISH (OVER NICKEL):
42 = SELECTIVE GOLD ON CONTACT AREA,
100% TIN ON TAILS
46 = 100% TIN

ELECTRICAL:
CURRENT RATING = 3A MAX
CONTACT RESISTANCE = 30mΩ MAX (TIN),
25mΩ MAX (GOLD)
INSULATION RESISTANCE = 1,000Ω MIN
DIELECTRIC STRENGTH = 750V AC/DC

MECHANICAL:
DURABILITY = 50 OPERATIONS (TIN),
300 OPERATIONS (GOLD)

ENVIRONMENTAL:
TEMPERATURE RANGE = -40°C TO +105°C

PACKING:
BAG
FOR COMPLETE SPECIFICATION, SEE COMPONENT
SPECIFICATION C001XX (LATEST ISSUE)

NOTES:

- SEE DRAWING M20-877XXXXP FOR PICK AND PLACE TUBE OPTION, M20-877XXXX FOR LOOSE OPTION.
- FOR 4 WAYS AND LESS, CAP LENGTH = 6.00mm.
- FOR REELING DETAILS SEE SHEET 4.
- ALL TOLERANCES ARE ± 0.15 mm UNLESS OTHERWISE STATED.

MGP	20	04.03.19	21824
NAME	ISS.	DATE	C/NOTE
APPROVED: MGP			
CHECKED: SB			
DRAWN: J. KEIR			
CUSTOMER REF.:			
ASSEMBLY DRG:			

HARWIN

www.harwin.com
technical@harwin.com

THIS DRAWING AND ANY INFORMATION OR DESCRIPTIVE MATTER SET OUT HEREON ARE CONFIDENTIAL AND COPYRIGHT PROPERTY OF THE HARWIN GROUP AND MUST NOT BE DISCLOSED, LOANED, COPIED OR USED FOR MANUFACTURING, TENDERING OR FOR ANY OTHER PURPOSE WITHOUT THEIR WRITTEN PERMISSION.

TOLERANCES
X = ± 1 mm
X.X = ± 0.50 mm
X.XX = ± 0.20 mm
X.XXX = ± 0.01 mm
ANGLES = $\pm 5^\circ$
UNLESS STATED

MATERIAL:
SEE TABLE

FINISH: SEE TABLE

S/AREA: mm²

TITLE: 2.54mm PITCH SIL
SMT VERTICAL PIN HEADER WITH
P/PLACE, TAPE & REEL (L/HAND)

DRAWING NUMBER:
M20-877XXXXR

SHT
3 OF 4

Customer Information Sheet

DRAWING No.: M20-877XXXXR

IF IN DOUBT - ASK

©

NOT TO SCALE

THIRD ANGLE PROJECTION

ALL DIMENSIONS IN mm

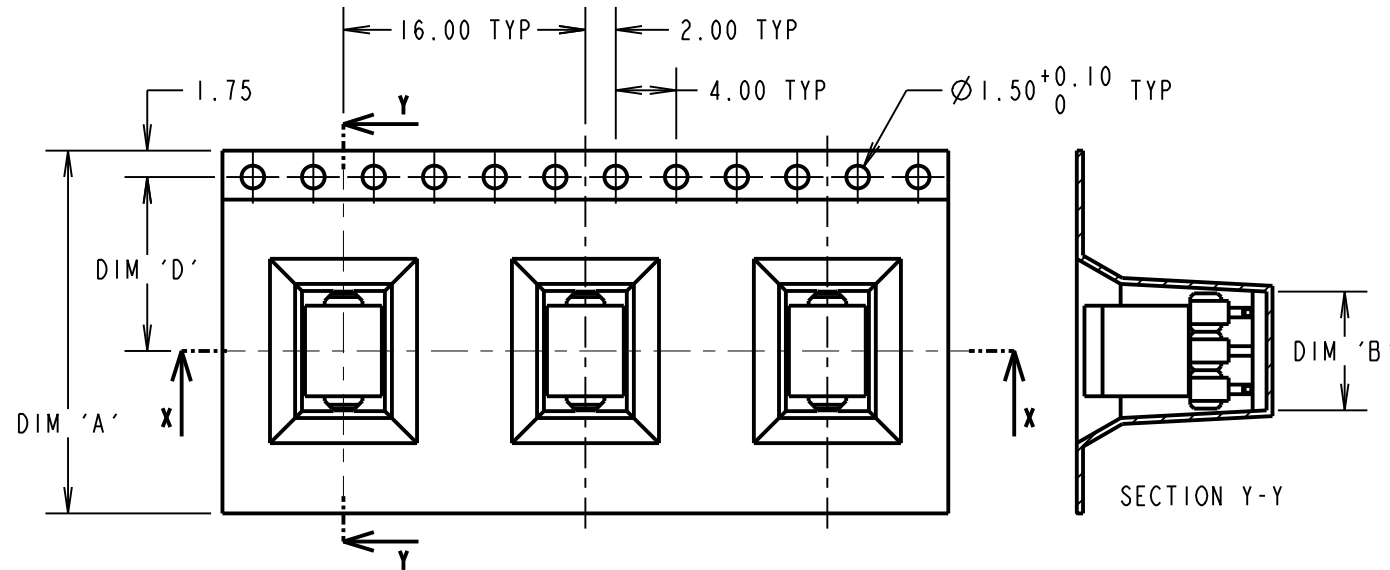

SECTION X-X

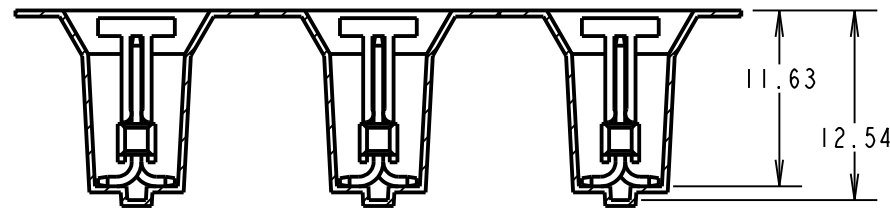

TAPE DETAILS FOR 02 & 03 CONTACTS

REEL DETAILS

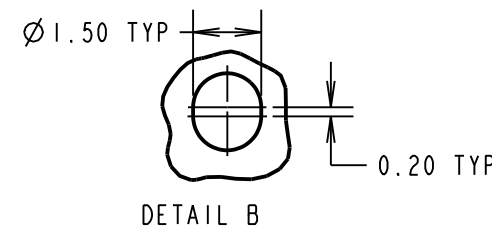
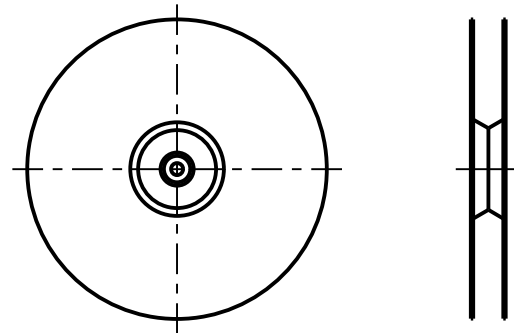

DETAIL B

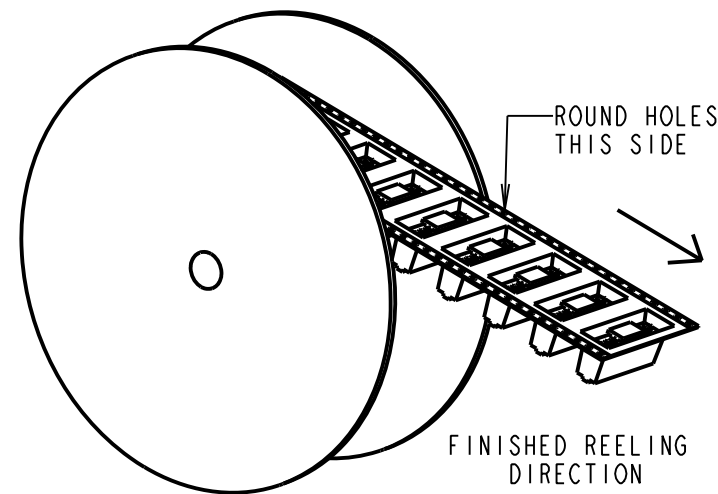

FINISHED REELING DIRECTION

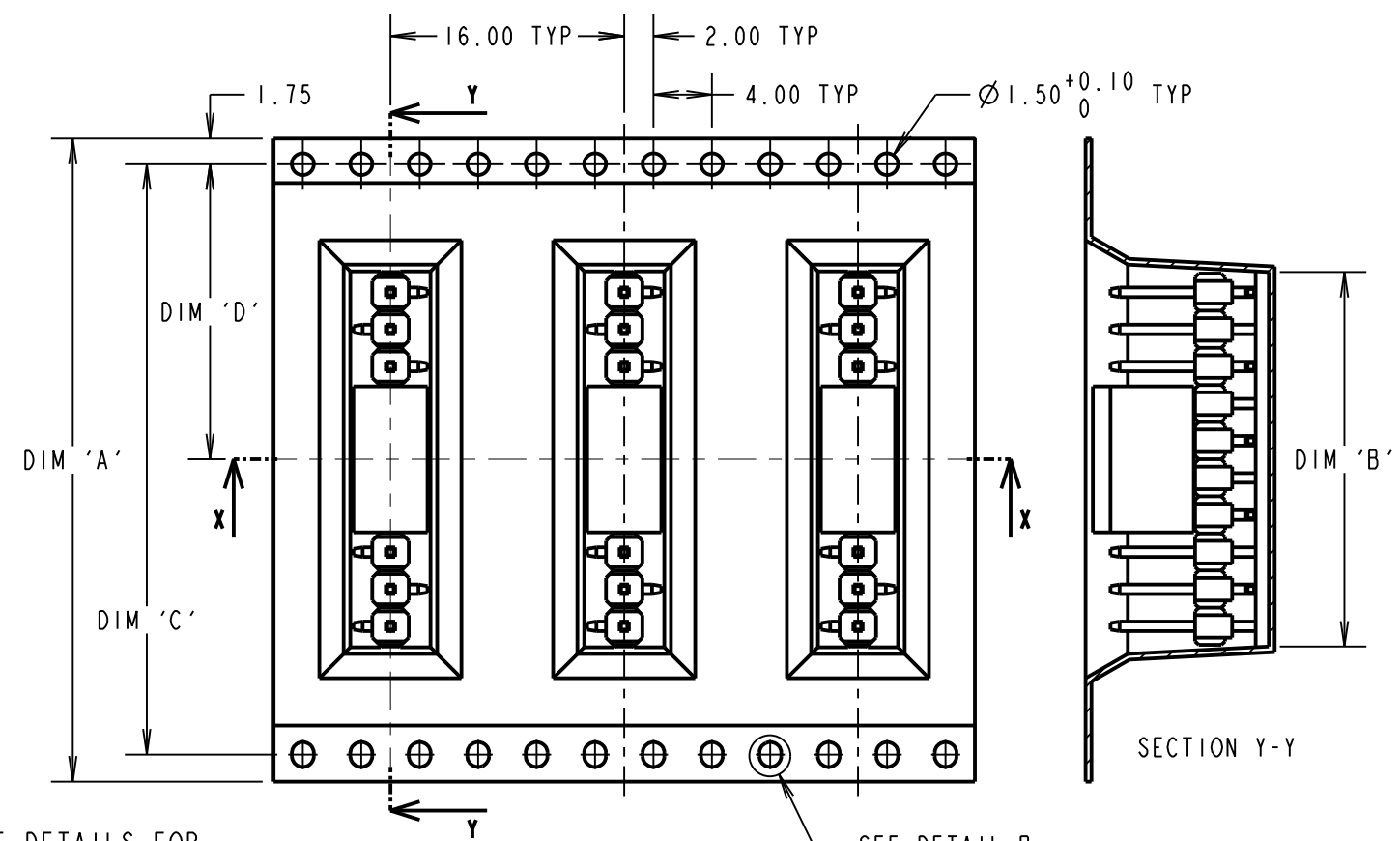

TAPE DETAILS FOR 04, 05, 06, 08, 10, 15, 16 & 19 CONTACTS

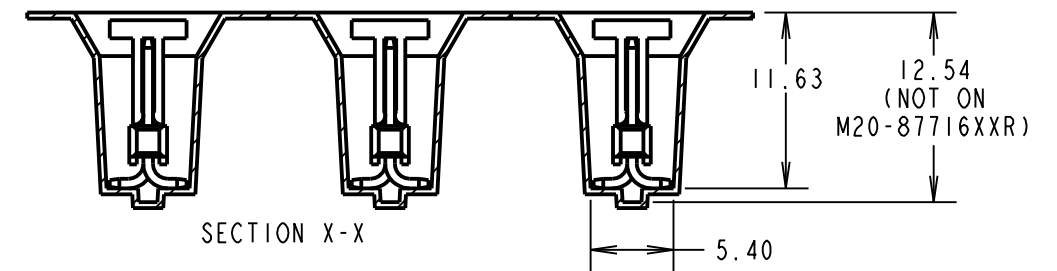

SECTION X-X

HARWIN PART No.	DIM 'A'	DIM 'B'	DIM 'C'	DIM 'D'
M20-87702XXR	24.00±0.30	5.28	-	11.50
M20-87703XXR		7.80	-	11.50
M20-87704XXR	32.00±0.30	10.50	28.40	14.20
M20-87705XXR		13.10		
M20-87706XXR		15.60		
M20-87708XXR		20.60		
M20-87710XXR	44.00±0.30	25.80	40.40	20.20±0.15
M20-87715XXR	56.00±0.30	38.33	52.40	26.20±0.15
M20-87716XXR	72.00±0.30	40.90	68.40	34.20±0.30
M20-87719XXR		48.24		

- NOTES:
- QUANTITY PER REEL = 450.
 - FOR CONNECTOR DIMENSIONS, SEE SHEET 3.
 - TAPE AND REELING IS IN GENERAL ACCORDANCE WITH ELECTRONIC INDUSTRIES ASSOCIATION EIA-481.

MGP	20	04.03.19	21824
NAME	ISS.	DATE	C/NOTE
APPROVED: MGP			
CHECKED: SB			
DRAWN: J. KEIR			
CUSTOMER REF.:			
ASSEMBLY DRG:			

HARWIN

www.harwin.com
technical@harwin.com

THIS DRAWING AND ANY INFORMATION OR DESCRIPTIVE MATTER SET OUT HEREON ARE CONFIDENTIAL AND COPYRIGHT PROPERTY OF THE HARWIN GROUP AND MUST NOT BE DISCLOSED, LOANED, COPIED OR USED FOR MANUFACTURING, TENDERING OR FOR ANY OTHER PURPOSE WITHOUT THEIR WRITTEN PERMISSION.

TOLERANCES
X. = ±1mm
X.X = ±0.50mm
X.XX = ±0.20mm
X.XXX = ±0.01mm
ANGLES = ±5°
UNLESS STATED

MATERIAL:
SEE ABOVE
FINISH: SEE ABOVE
S/AREA: mm²

TITLE: 2.54mm PITCH SIL SMT VERTICAL PIN HEADER WITH P/PLACE, TAPE & REEL (L/HAND)

DRAWING NUMBER: **M20-877XXXXR** SHT 4 OF 4