

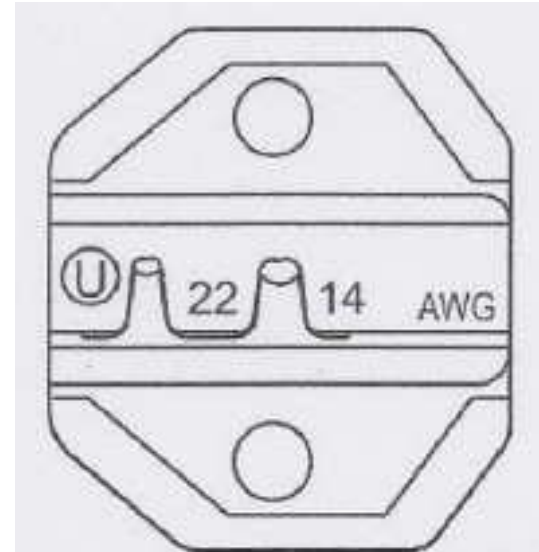

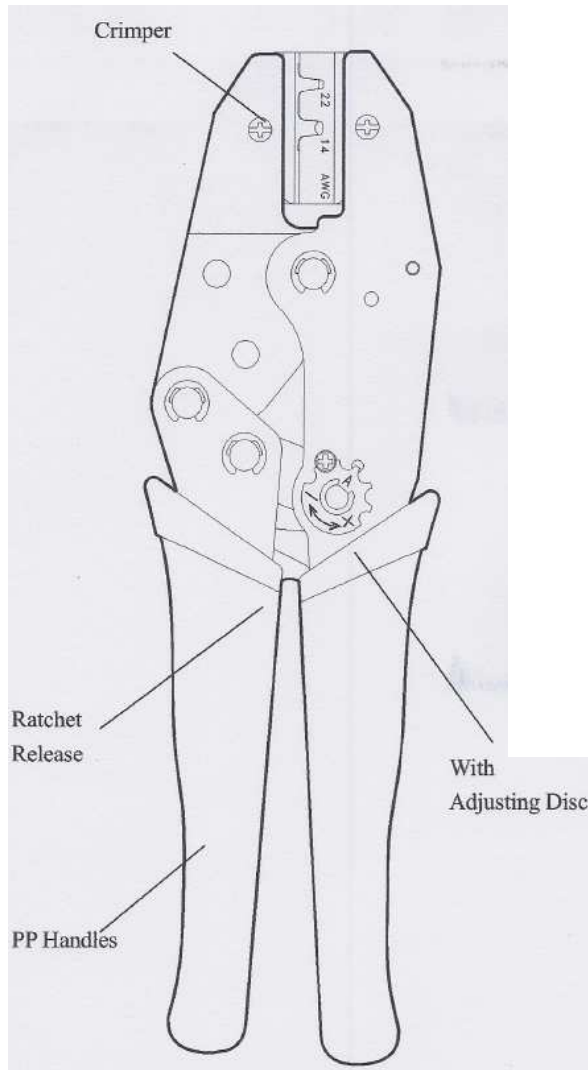

DESCRIPTION: D-SUB RATCHET CRIMP TOOL, 14-22 AWG
 MODEL NUMBER: 24-8644P
 CRIMP TOOL: N/A
 IMPEDANCE: N/A
 FREQUENCY RANGE: N/A
 MATERIAL: FRAME - MIDDLE CARBON STEEL
 CRIMPER - MADE OF OFF WAX
 RoHS COMPLIANCE: N/A
 TECHNICAL DETAIL: N/A
 LENGTH: 8.7" (220mm)
 WEIGHT: 500g

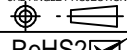

 <small>This PROPRIETARY Document is property of Cinch Connectivity Solutions. It is confidential in nature, non-transferable, and issued with the clear understanding that it is not to be copied or reused without permission and is returnable upon demand.</small> <small>INTERPRET DRAWING IN ACCORDANCE WITH ASME Y14.5-2009.</small>	<small>3RD ANGLE PROJECTION</small> 	AIM-Cambridge	
	RoHS2 <input checked="" type="checkbox"/> 2011/65/EU <small>UNLESS OTHERWISE SPECIFIED UNITS: METRIC</small> $-X \pm .2-$ $-XX \pm .07-$ ANGLES $\pm 2^\circ$	Title: D-Sub Ratchet Tool, 14-22AWG and V.35 Contacts Gauge Model No. 24-8644P	

Mouser Electronics

Authorized Distributor

Click to View Pricing, Inventory, Delivery & Lifecycle Information:

[Cinch Connectivity Solutions:](#)

[24-8644P](#)