



RabbitCore RCM3200

C-Programmable Module with Ethernet

User's Manual

019-0118 • 080528-N

RabbitCore RCM3200 User's Manual

Part Number 019-0118 • 080528–N • Printed in U.S.A.

©2002–2008 Digi International Inc. • All rights reserved.

No part of the contents of this manual may be reproduced or transmitted in any form or by any means without the express written permission of Digi International.

Permission is granted to make one or more copies as long as the copyright page contained therein is included. These copies of the manuals may not be let or sold for any reason without the express written permission of Digi International.

Digi International reserves the right to make changes and improvements to its products without providing notice.

Trademarks

Rabbit, RabbitCore, and Dynamic C are registered trademarks of Digi International Inc.

Rabbit 3000 is a trademark of Digi International Inc.

The latest revision of this manual is available on the Rabbit Web site, www.rabbit.com, for free, unregistered download.

Rabbit Semiconductor Inc.

www.rabbit.com

TABLE OF CONTENTS

Chapter 1. Introduction	1
1.1 RCM3200 Features	2
1.2 Comparing the RCM3209/RCM3229 and RCM3200/RCM3220	4
1.3 Advantages of the RCM3200	5
1.4 Development and Evaluation Tools.....	6
1.4.1 RCM3200 Development Kit	6
1.4.2 Software	7
1.4.3 Connectivity Interface Kits	7
1.4.4 Online Documentation	7
Chapter 2. Hardware Setup	9
2.1 Install Dynamic C	9
2.2 Hardware Connections.....	10
2.2.1 Step 1 — Attach Module to Prototyping Board.....	11
2.2.2 Step 2 — Connect Programming Cable.....	12
2.2.2.1 RCM3209 and RCM3229	12
2.2.2.2 RCM3200 and RCM3220	13
2.2.3 Step 3 — Connect Power	14
2.2.3.1 Overseas Development Kits	15
2.3 Starting Dynamic C	16
2.4 Run a Sample Program	16
2.4.1 Troubleshooting	16
2.5 Where Do I Go From Here?	17
2.5.1 Technical Support	17
Chapter 3. Running Sample Programs	19
3.1 Introduction.....	19
3.2 Sample Programs	20
3.2.1 Serial Communication.....	21
3.2.2 Other Sample Programs	22
Chapter 4. Hardware Reference	23
4.1 RCM3200 Digital Inputs and Outputs	24
4.1.1 Memory I/O Interface	29
4.1.2 Other Inputs and Outputs	29
4.1.3 5 V Tolerant Inputs	29
4.2 Serial Communication	30
4.2.1 Serial Ports	30
4.2.2 Ethernet Port (RCM3200 only).....	31
4.2.3 Serial Programming Port.....	32
4.3 Serial Programming Cable	33
4.3.1 Changing Between Program Mode and Run Mode	33
4.3.2 Standalone Operation of the RCM3200.....	34
4.4 Other Hardware.....	35
4.4.1 Clock Doubler	35
4.4.2 Spectrum Spreader	35

4.5 Memory	36
4.5.1 SRAM.....	36
4.5.2 Flash EPROM.....	36
4.5.3 Dynamic C BIOS Source Files.....	36
Chapter 5. Software Reference	37
5.1 More About Dynamic C	37
5.2 Dynamic C Function Calls	39
5.2.1 Digital I/O.....	39
5.2.2 SRAM Use.....	39
5.2.3 Serial Communication Drivers	40
5.2.4 TCP/IP Drivers	40
5.2.5 Prototyping Board Function Calls	40
5.2.5.1 Board Initialization	41
5.3 Upgrading Dynamic C	42
5.3.1 Extras	42
Chapter 6. Using the TCP/IP Features	43
6.1 TCP/IP Connections	43
6.2 TCP/IP Primer on IP Addresses	45
6.2.1 IP Addresses Explained.....	47
6.2.2 How IP Addresses are Used	48
6.2.3 Dynamically Assigned Internet Addresses.....	49
6.3 Placing Your Device on the Network	50
6.4 Running TCP/IP Sample Programs.....	51
6.4.1 How to Set IP Addresses in the Sample Programs.....	52
6.4.2 How to Set Up your Computer's IP Address for Direct Connect	53
6.4.3 Dynamic C Compiler Settings.....	53
6.5 Run the PINGME.C Sample Program.....	54
6.6 Running More Sample Programs With Direct Connect.....	54
6.7 Where Do I Go From Here?.....	55
Appendix A. RCM3200 Specifications	57
A.1 Electrical and Mechanical Characteristics	58
A.1.1 Headers	61
A.1.2 Physical Mounting	62
A.2 Bus Loading	63
A.3 Rabbit 3000 DC Characteristics	66
A.4 I/O Buffer Sourcing and Sinking Limit.....	67
A.5 Conformal Coating	68
A.6 Jumper Configurations	69
Appendix B. Prototyping Board	71
B.1 Introduction	72
B.1.1 Prototyping Board Features	73
B.2 Mechanical Dimensions and Layout	75
B.3 Power Supply.....	76
B.4 Using the Prototyping Board.....	77
B.4.1 Adding Other Components	78
B.4.2 Measuring Current Draw	78
B.4.3 Other Prototyping Board Modules and Options	79
B.5 Use of Rabbit 3000 Parallel Ports.....	80
Appendix C. LCD/Keypad Module	83
C.1 Specifications.....	83
C.2 Contrast Adjustments for All Boards	85

C.3 Keypad Labeling	86
C.4 Header Pinouts	87
C.4.1 I/O Address Assignments	87
C.5 Mounting LCD/Keypad Module on the Prototyping Board	88
C.6 Bezel-Mount Installation	89
C.6.1 Connect the LCD/Keypad Module to Your Prototyping Board	91
C.7 LCD/Keypad Module Function Calls	92
C.7.1 LCD/Keypad Module Initialization	92
C.7.2 LEDs	92
C.7.3 LCD Display	93
C.7.4 Keypad	108
C.8 Sample Programs	111
Appendix D. Power Supply	113
D.1 Power Supplies	113
D.1.1 Battery Backup	113
D.1.2 Battery-Backup Circuit	114
D.1.3 Reset Generator	115
D.2 Optional +5 V Output	115
Appendix E. Motor Control Option	117
E.1 Overview	117
E.2 Header J6	118
E.3 Using Parallel Port F	119
E.3.1 Parallel Port F Registers	119
E.4 PWM Outputs	122
E.5 PWM Registers	123
E.6 Quadrature Decoder	124
Index	127
Schematics	131



1. INTRODUCTION

The RCM3200 RabbitCore[®] module is designed to be the heart of embedded control systems. The RCM3200 features an integrated 10/100Base-T Ethernet port and provides for LAN and Internet-enabled systems to be built as easily as serial-communication systems.

Throughout this manual, the term RCM3200 refers to the complete series of RCM3200 RabbitCore modules unless other production models are referred to specifically.

The RCM3200 has a Rabbit[®] 3000 microprocessor operating at 44.2 MHz, data and program execution SRAM, flash memory, two clocks (main oscillator and timekeeping), and the circuitry necessary for reset and management of battery backup of the Rabbit 3000's internal real-time clock and the data SRAM. Two 34-pin headers bring out the Rabbit 3000 I/O bus lines, parallel ports, and serial ports.

The RCM3200 receives its +3.3 V power from the customer-supplied motherboard on which it is mounted. The RabbitCore RCM3200 can interface with all kinds of CMOS-compatible digital devices through the motherboard.

1.1 RCM3200 Features

- Small size: 1.85" x 2.73" x 0.86"
(47 mm x 69 mm x 22 mm)
- Microprocessor: Rabbit 3000 running at 44.2 MHz
- (RCM3200 only) 10/100Base-T Ethernet port with supporting LEDs
- 52 parallel 5 V tolerant I/O lines: 44 configurable for I/O, 4 fixed inputs, 4 fixed outputs
- Two additional digital inputs, two additional digital outputs
- External reset input
- Alternate I/O bus can be configured for 8 data lines and 6 address lines (shared with parallel I/O lines), I/O read/write
- Ten 8-bit timers (six cascadable) and one 10-bit timer with two match registers
- 512K flash memory, 512K program execution SRAM, 256K data SRAM
- Real-time clock
- Watchdog supervisor
- Provision for customer-supplied backup battery via connections on header J2
- 10-bit free-running PWM counter and four width registers
- Two-channel Input Capture can be used to time input signals from various port pins
- Two-channel Quadrature Decoder accepts inputs from external incremental encoder modules
- Six CMOS-compatible serial ports: maximum asynchronous baud rate of 5.5 Mbps. Four ports are configurable as a clocked serial port (SPI), and two ports are configurable as SDLC/HDLC serial ports.
- Supports 1.15 Mbps IrDA transceiver.

The RCM3209 and RCM3229 modules are similar in form, dimensions, and function to the RCM3200/RCM3220, and based on the RCM3900 RabbitCore modules which were first released in 2008.

There are two RCM3200 production models. Contact your Rabbit sales representative for details.

Table 1 below summarizes the main features of the RCM3200.

Table 1. RCM3200 Features

Feature	RCM3200	RCM3210*	RCM3220
Microprocessor	Rabbit 3000 running at 44.2 MHz	Rabbit 3000 running at 29.5 MHz	Rabbit 3000 running at 44.2 MHz
Flash Memory	512K	256K	512K
Program Data SRAM	256K	128K	256K
Program Execution SRAM	512K	—	512K
RJ-45 Ethernet Connector, Filter Capacitors, and LEDs	Yes		No
Serial Ports	6 shared high-speed, CMOS-compatible ports: 6 are configurable as asynchronous serial ports; 4 are configurable as clocked serial ports (SPI); 2 are configurable as SDLC/HDLC serial ports; 1 asynchronous serial port is dedicated for programming		

* The RCM3210 was discontinued in July, 2004, and is no longer offered.

The RCM3200 can be programmed locally, remotely, or via a network using appropriate interface hardware.

Appendix A, “RCM3200 Specifications,” provides detailed specifications for the RCM3200.

1.2 Comparing the RCM3209/RCM3229 and RCM3200/RCM3220

We can no longer obtain certain components for the RCM3200/RCM3220 RabbitCore modules that support the originally specified -40°C to $+70^{\circ}\text{C}$ temperature range. Instead of changing the design of the RCM3200/RCM3220 RabbitCore modules to handle available components specified for the original temperature range, we decided to develop a new product line — the RCM3209/RCM3229 — based on the RCM3900 RabbitCore modules that were released for the same reason.

The RCM3209/RCM3229 modules are similar in form, dimensions, and function to the RCM3200/RCM3220 modules. We strongly recommend that existing RCM3200/RCM3220 customers and designers of new systems consider using the new RCM3209/RCM3229 RabbitCore modules.

This section compares the two lines of RabbitCore modules.

- **Temperature Specifications** — RCM3200/RCM3220 RabbitCore modules manufactured after May, 2008, are specified to operate at 0°C to $+70^{\circ}\text{C}$. The RCM3209/RCM3229, rated for -40°C to $+85^{\circ}\text{C}$, are offered to customers requiring a larger temperature range after May, 2008.
- **Maximum Current** — The RCM3200/RCM3220 draws 255 mA vs. the 325 mA required by the RCM3209 (with Ethernet) or 190 mA (RCM3229 without Ethernet).
- **LEDs** — The **LNK/ACT** LEDs have been combined to one LED on the RCM3209, and the RCM3209 has an **FDX/COL** LED where the **ACT** LED was on the RCM3200. The RCM3229, like the RCM3220, has no LEDs and no Ethernet.
- **Ethernet chip.** A different Ethernet controller chip is used on the RCM3209. The Ethernet chip is able to detect automatically whether a crossover cable or a straight-through cable is being used in a particular setup, and will configure the signals on the Ethernet jack interface. The RCM3229, like the RCM3220, has no Ethernet interface.
- **Dynamic C** — You may run an application developed for the RCM3200/RCM3220 on the RCM3209/RCM3229 after you recompile it using Dynamic C v. 9.60 or later. The new Dynamic C release incorporates many of the modules that previously had to be purchased separately.

1.3 Advantages of the RCM3200

- Fast time to market using a fully engineered, “ready to run” microprocessor core.
- Competitive pricing when compared with the alternative of purchasing and assembling individual components.
- Easy C-language program development and debugging
- Program Download Utility and cloning board options for rapid production loading of programs.
- Generous memory size allows large programs with tens of thousands of lines of code, and substantial data storage.
- Integrated Ethernet port for network connectivity, royalty-free TCP/IP software.

1.4 Development and Evaluation Tools

1.4.1 RCM3200 Development Kit

The RCM3200 Development Kit contains the hardware you need to use your RCM3200 series RabbitCore module.

- RCM3209 module.
- Prototyping Board.
- Universal AC adapter, 12 V DC, 1 A (includes Canada/Japan/U.S., Australia/N.Z., U.K., and European style plugs).
- USB programming cable with 10-pin header.
- *Dynamic C* CD-ROM, with complete product documentation on disk.
- *Getting Started* instructions.
- Accessory parts for use on the Prototyping Board.
- *Rabbit 3000 Processor Easy Reference* poster.
- Registration card.

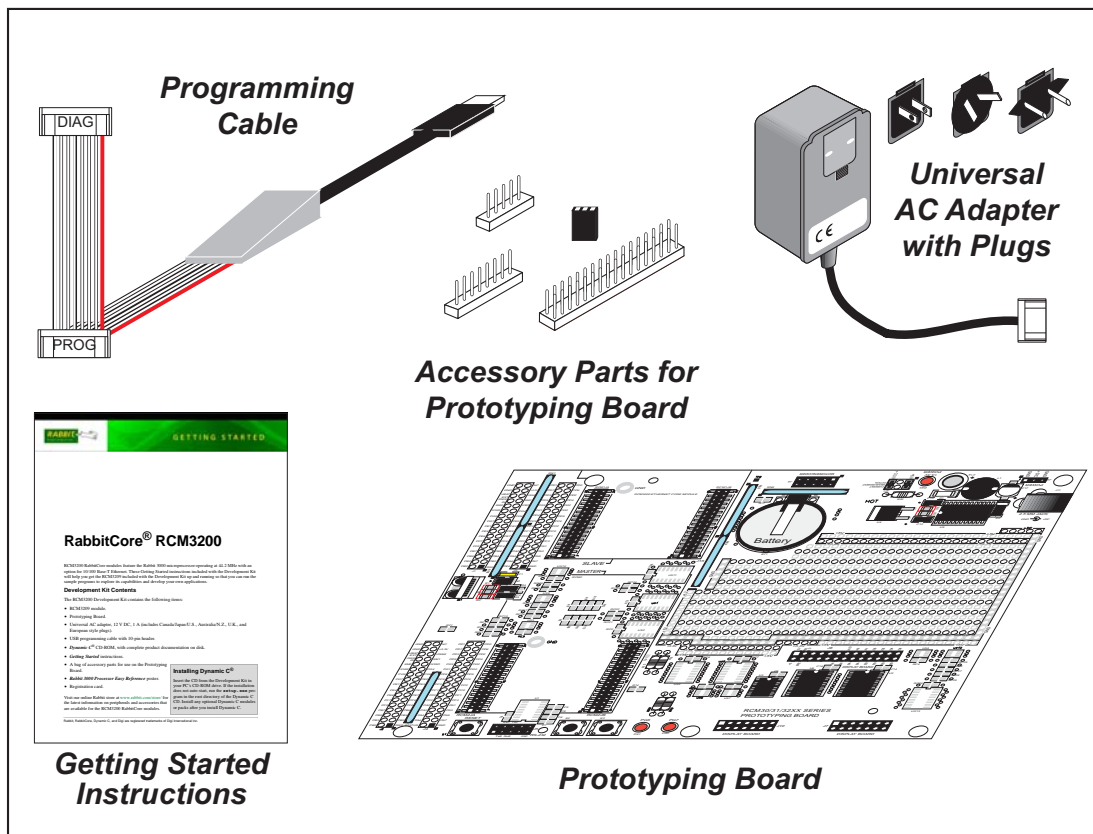

Figure 1. RCM3200 Development Kit

1.4.2 Software

The RCM3200 and the RCM3220 are programmed using version 9.21 or later of Rabbit's Dynamic C. A compatible version is included on the Development Kit CD-ROM.

Dynamic C v. 9.60, which is required for the related RCM3209 and RCM3229 RabbitCore modules, includes the popular μ C/OS-II real-time operating system, point-to-point protocol (PPP), FAT file system, RabbitWeb, and other select libraries that were previously sold as individual Dynamic C modules.

Rabbit also offers for purchase the Rabbit Embedded Security Pack featuring the Secure Sockets Layer (SSL) and a specific Advanced Encryption Standard (AES) library. In addition to the Web-based technical support included at no extra charge, a one-year telephone-based technical support subscription is also available for purchase. Visit our Web site at www.rabbit.com for further information and complete documentation, or contact your Rabbit sales representative or authorized distributor.

1.4.3 Connectivity Interface Kits

Rabbit has available a Connector Adapter Board.

- Connector Adapter Board (Part No. 151-0114)—allows you to plug the RCM3200/RCM3220 whose headers have a 2 mm pitch into header sockets with a 0.1" pitch.

Visit our Web site at www.rabbit.com or contact your Rabbit sales representative or authorized distributor for further information.

1.4.4 Online Documentation

The online documentation is installed along with Dynamic C, and an icon for the documentation menu is placed on the workstation's desktop. Double-click this icon to reach the menu. If the icon is missing, use your browser to find and load **default.htm** in the **docs** folder, found in the Dynamic C installation folder.

The latest versions of all documents are always available for free, unregistered download from our Web sites as well.

2. HARDWARE SETUP

This chapter describes how to set up and connect an RCM3200 series module and the Prototyping Board included in the Development Kit.

NOTE: This chapter (and this manual) assume that you have the RCM3200 Development Kit. If you purchased an RCM3200 series module by itself, you will have to adapt the information in this chapter and elsewhere to your test and development setup.

2.1 Install Dynamic C

To develop and debug programs for an RCM3200 series RabbitCore module (and for all other Rabbit hardware), you must install and use Dynamic C.

If you have not yet installed Dynamic C, do so now by inserting the Dynamic C CD from the Development Kit in your PC's CD-ROM drive. If autorun is enabled, the CD installation will begin automatically.

If autorun is disabled or the installation otherwise does not start, use the Windows **Start | Run** menu or Windows Disk Explorer to launch `setup.exe` from the root folder of the CD-ROM.

The installation program will guide you through the installation process. Most steps of the process are self-explanatory.

Dynamic C uses a COM (serial) port to communicate with the target development system. The installation allows you to choose the COM port that will be used. The default selection is COM1. You may select any available port for Dynamic C's use. If you are not certain which port is available, select COM1. This selection can be changed later within Dynamic C.

NOTE: The installation utility does not check the selected COM port in any way. Specifying a port in use by another device (mouse, modem, etc.) may lead to a message such as "could not open serial port" when Dynamic C is started.

Once your installation is complete, you will have up to three icons on your PC desktop. One icon is for Dynamic C, one opens the documentation menu, and the third is for the Rabbit Field Utility, a tool used to download precompiled software to a target system.

If you have purchased the optional Dynamic C Rabbit Embedded Security Pack, install it after installing Dynamic C. You must install the Rabbit Embedded Security Pack in the same directory where Dynamic C was installed.

2.2 Hardware Connections

There are three steps to connecting the Prototyping Board for use with Dynamic C and the sample programs:

1. Attach the RCM3200 series RabbitCore module to the Prototyping Board.
2. Connect the programming cable between the RCM3200 series RabbitCore module and the workstation PC.
3. Connect the power supply to the Prototyping Board.

2.2.1 Step 1 — Attach Module to Prototyping Board

Turn the RCM3200 series module so that the Ethernet jack extends off the Prototyping Board, as shown in Figure 2 below. Align the pins from the headers on the bottom side of the module into header sockets RCM2JA and RCM2JB on the Prototyping Board (these sockets were labeled J12 and J13 on earlier versions of the Prototyping Board).

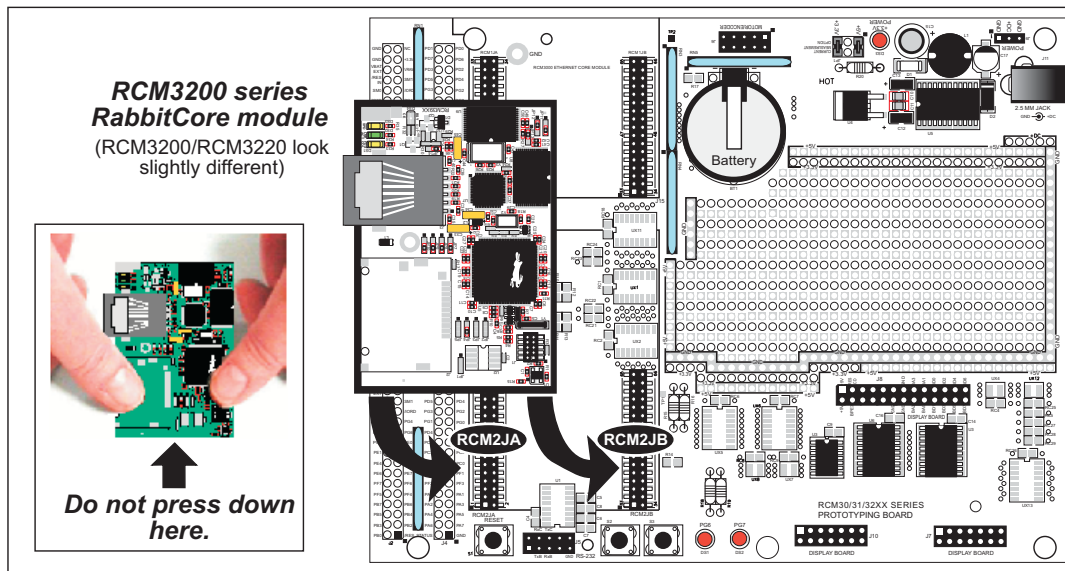

Figure 2. Install the RCM3200 Series Module on the Prototyping Board

Although you can install a single module into either the **MASTER** or the **SLAVE** position on the Prototyping Board, all the Prototyping Board features (switches, LEDs, serial port drivers, etc.) are connected to the **MASTER** position — install a single module in the **MASTER** position.

NOTE: It is important that you line up the pins from the headers on the bottom side of the RCM3200 module exactly with the corresponding pins of header sockets RCM2JA and RCM2JB on the Prototyping Board. The header pins may become bent or damaged if the pin alignment is offset, and the module will not work. Permanent electrical damage to the module may also result if a misaligned module is powered up.

Press the module's pins firmly into the Prototyping Board header sockets—press down in the area above the header pins using your thumbs or fingers over the connectors as shown in Figure 2. Do **not** press down on the middle of the RCM3200 series module to avoid flexing the module, which could damage the module or the components on the module.

Should you need to remove the RCM3200 module, grasp it with your fingers along the sides by the connectors and gently work the module up to pull the pins away from the sockets where they are installed. Do **not** remove the module by grasping it at the top and bottom.

2.2.2 Step 2 — Connect Programming Cable

The programming cable connects the RCM3200 to the PC running Dynamic C to download programs and to monitor the RCM3200 module during debugging.

2.2.2.1 RCM3209 and RCM3229

Connect the 10-pin connector of the programming cable labeled **PROG** to header J1 on the RCM3209/RCM3229 module as shown in Figure 3(a). Be sure to orient the marked (usually red) edge of the cable towards pin 1 of the connector. (Do not use the **DIAG** connector, which is used for a normal serial connection.)

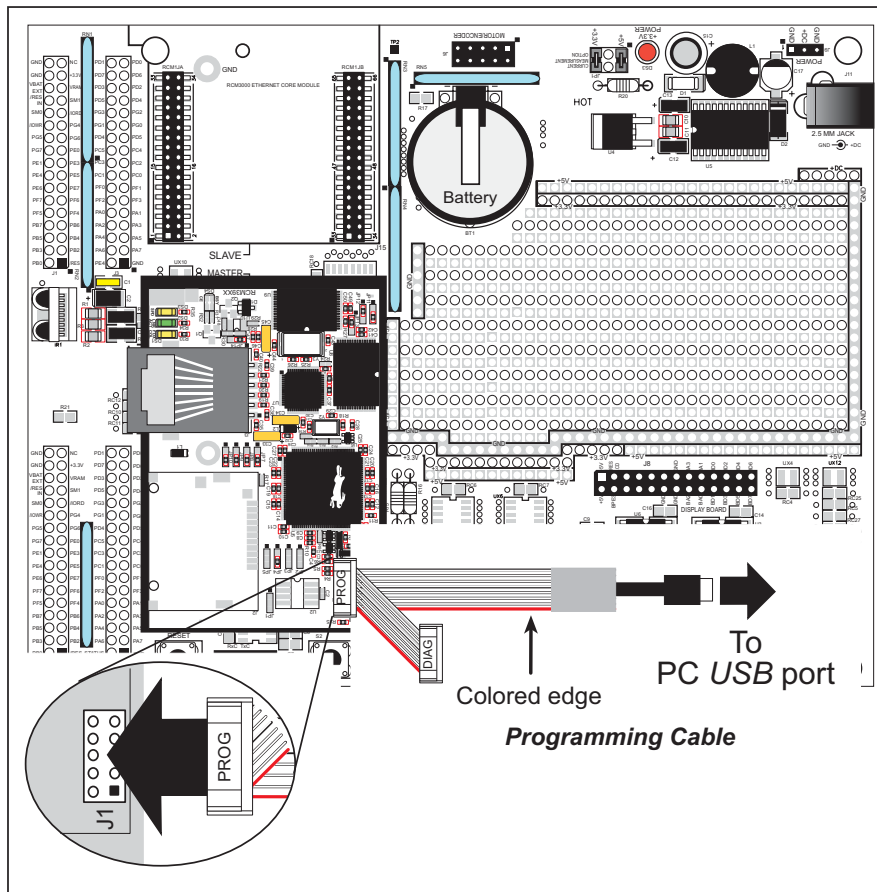

Figure 3(a). Connect Programming Cable to RCM3209/RCM3229

Connect the other end of the programming cable to an available USB port on your PC or workstation. Your PC should recognize the new USB hardware, and the LEDs in the shrink-wrapped area of the USB programming cable will flash.

2.2.2.2 RCM3200 and RCM3220

Connect the 10-pin connector of the programming cable labeled **PROG** to header J3 on the RCM3200 module as shown in Figure 3(b). Be sure to orient the marked (usually red) edge of the cable towards pin 1 of the connector. (Do not use the **DIAG** connector, which is used for a normal serial connection.)

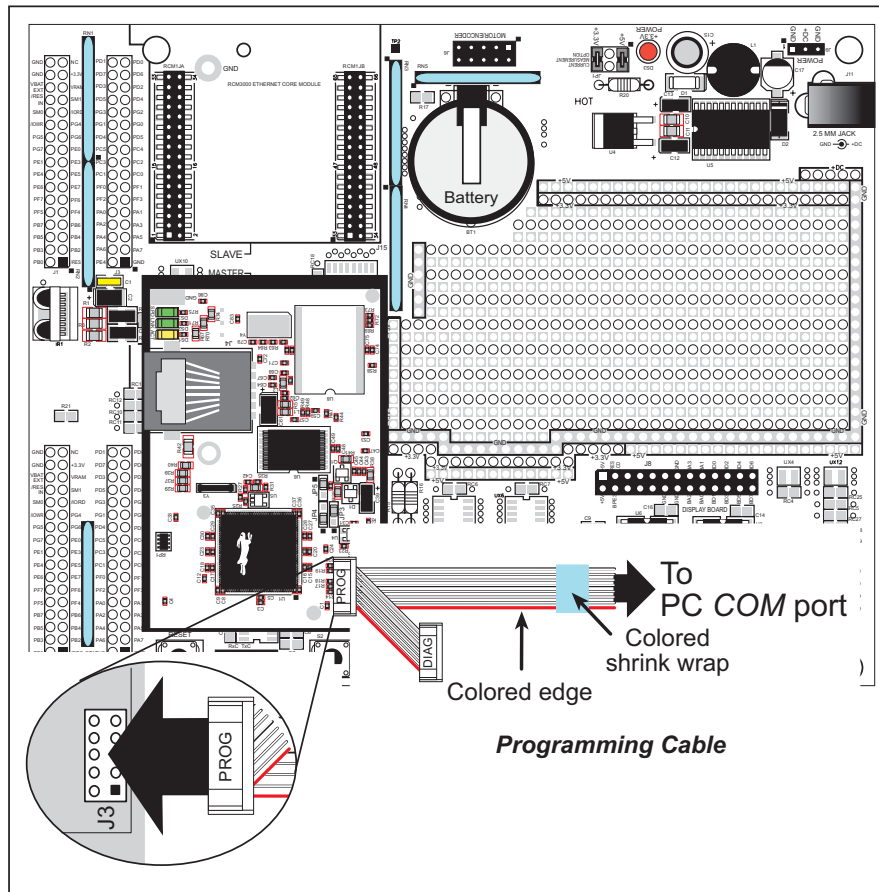

Figure 3(b). Connect Programming Cable to RCM3200

NOTE: Be sure to use the serial programming cable (part number 101-0542)—the programming cable has blue shrink wrap around the RS-232 converter section located in the middle of the cable. The USB programming cable and programming cables with red or clear shrink wrap from other Rabbit kits are not designed to work with RCM3200/RCM3220 modules.

Connect the other end of the programming cable to a COM port on your PC.

NOTE: It may be possible to use an RS-232/USB converter with the serial programming described in this section. An RS-232/USB converter (part number 20-151-0178) is available through the [Web store](#). Note that not all RS-232/USB converters work with Dynamic C.

2.2.3 Step 3 — Connect Power

When all other connections have been made, you can connect power to the Prototyping Board.

If you have the universal power supply, prepare the AC adapter for the country where it will be used by selecting the plug. The RCM3200 Development Kit presently includes Canada/Japan/U.S., Australia/N.Z., U.K., and European style plugs. Snap in the top of the plug assembly into the slot at the top of the AC adapter as shown in Figure 4, then press down on the spring-loaded clip below the plug assembly to allow the plug assembly to click into place.

Connect the 3-pin connector from the AC adapter to header J9 on the Prototyping Board as shown in Figure 4 below. A plug-type jack is available at J11 for other AC adapters.

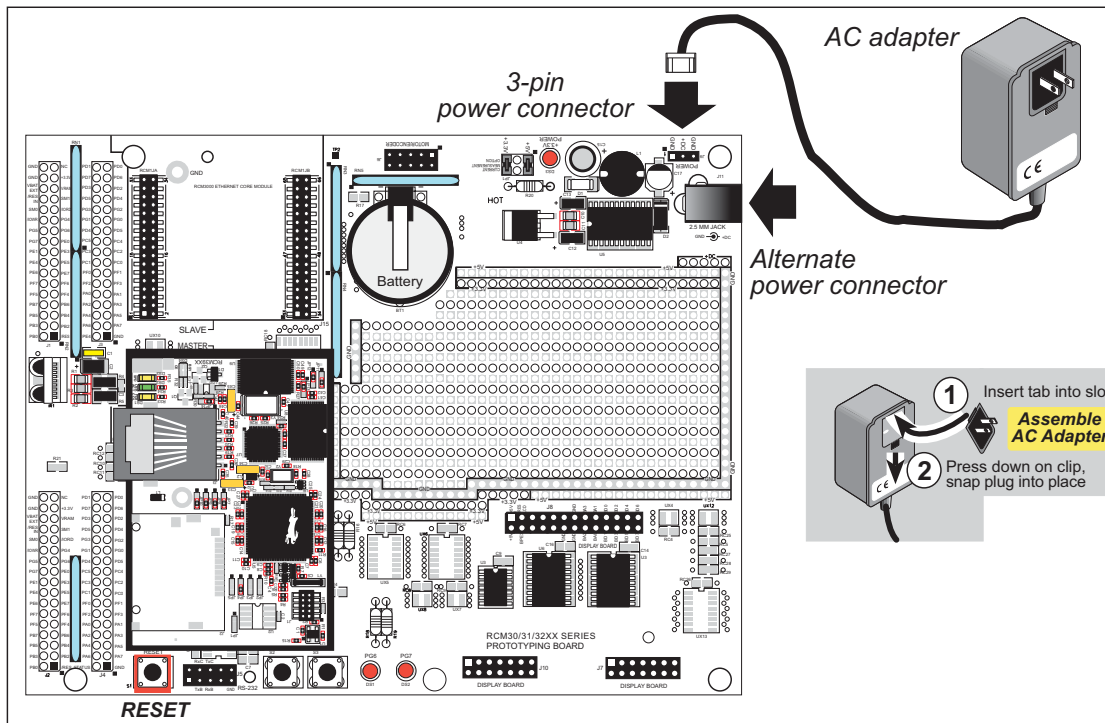

Figure 4. Power Supply Connections

Plug in the AC adapter. The red power lamp on the Prototyping Board to the left of jack J11 should light up. The RCM3200 and the Prototyping Board are now ready to be used.

NOTE: A **RESET** button is provided on the Prototyping Board to allow hardware reset without disconnecting power.

To power down the Prototyping Board, unplug the power connector from J11. You should disconnect power before making any circuit adjustments in the prototyping area, changing any connections to the board, or removing the RCM3200 from the Prototyping Board.

2.2.3.1 Overseas Development Kits

Development kits sold outside North America up to May, 2008, included a header connector that may be connected to 3-pin header J9 on the Prototyping Board. The connector may be attached either way as long as it is not offset to one side. The red and black wires from the connector can then be connected to the positive and negative connections on your power supply. The power supply should deliver 8 V–24 V DC at 8 W.

2.3 Starting Dynamic C

NOTE: Dynamic C v. 9.60 or a later version is required if you are using an RCM3209 or an RCM3229 RabbitCore module.

Once the RCM3200 is connected as described in the preceding pages, start Dynamic C by double-clicking on the Dynamic C icon on your desktop or in your **Start** menu. Select **Code and BIOS in Flash, Run in RAM** on the “Compiler” tab in the Dynamic C **Options > Project Options** menu. Click **OK**.

If you are using a USB port to connect your computer to the RCM3200 module, choose **Options > Project Options** and select “Use USB to Serial Converter” under the **Communications** tab. Click **OK**.

2.4 Run a Sample Program

Use the **File** menu to open the sample program **PONG.C**, which is in the Dynamic C **SAMPLES** folder. Press function key **F9** to compile and run the program. The **STDIO** window will open on your PC and will display a small square bouncing around in a box.

This program shows that the CPU is working. The sample program described in Section 6.5, “Run the PINGME.C Sample Program,” tests the TCP/IP portion of the board.

2.4.1 Troubleshooting

If Dynamic C cannot find the target system (error message "**No Rabbit Processor Detected.** "):

- Check that the RCM3200 is powered correctly — the red power lamp on the Prototyping Board should be lit when the RCM3200 is mounted on the Prototyping Board and the AC adapter is plugged in.
- Check both ends of the programming cable to ensure that they are firmly plugged into the PC and the **PROG** connector, not the **DIAG** connector, is plugged in to the programming port on the RCM3200 with the marked (colored) edge of the programming cable towards pin 1 of the programming header.
- Ensure that the RCM3200 module is firmly and correctly installed in its connectors on the Prototyping Board.
- Dynamic C uses the COM port or USB port specified during installation. Select a different COM port within Dynamic C. From the **Options** menu, select **Project Options**, then select **Communications**. Select another COM port from the list, then click **OK**. Press **<Ctrl-Y>** to force Dynamic C to recompile the BIOS. If Dynamic C still reports it is unable to locate the target system, repeat the above steps until you locate the COM port used by the programming cable.
- If you get an error message when you plugged the programming cable into a USB port, you will have to install USB drivers. Drivers for Windows XP are available in the Dynamic C **Drivers\Rabbit USB Programming Cable\WinXP_2K** folder — double-click **DPInst.exe** to install the USB drivers. Drivers for other operating systems are available online at www.ftdichip.com/Drivers/VCP.htm.

If Dynamic C appears to compile the BIOS successfully, but you then receive a communication error message when you compile and load the sample program, it is possible that your PC cannot handle the higher program-loading baud rate. Try changing the maximum download rate to a slower baud rate as follows.

- Locate the **Serial Options** dialog in the Dynamic C **Options > Project Options > Communications** menu. Select a slower Max download baud rate.

If a program compiles and loads, but then loses target communication before you can begin debugging, it is possible that your PC cannot handle the default debugging baud rate. Try lowering the debugging baud rate as follows.

- Locate the **Serial Options** dialog in the Dynamic C **Options > Project Options > Communications** menu. Choose a lower debug baud rate.

2.5 Where Do I Go From Here?

If the sample program ran fine, you are now ready to go on to other sample programs and to develop your own applications. The source code for the sample programs is provided to allow you to modify them for your own use. The *RCM3200 User's Manual* also provides complete hardware reference information and describes the software function calls for the RCM3200 and the RCM3220, the Prototyping Board, and the optional LCD/keypad module. The *RCM3209/RCM3229 User's Manual* also provides complete hardware reference information and describes the software function calls for the RCM3209 and the RCM3229, the Prototyping Board, and the optional LCD/keypad module.

For advanced development topics, refer to the *Dynamic C User's Manual* and the *Dynamic C TCP/IP User's Manual*, also in the online documentation set.

2.5.1 Technical Support

NOTE: If you purchased your RCM3200 through a distributor or through a Rabbit partner, contact the distributor or partner first for technical support.

If there are any problems at this point:

- Use the Dynamic C **Help** menu to get further assistance with Dynamic C.
- Check the Rabbit Technical Bulletin Board and forums at www.rabbit.com/support/bb/ and at www.rabbit.com/forums/.
- Use the Technical Support e-mail form at www.rabbit.com/support/.

3. RUNNING SAMPLE PROGRAMS

To develop and debug programs for the RCM3200 (and for all other Rabbit hardware), you must install and use Dynamic C.

3.1 Introduction

To help familiarize you with the RCM3200 modules, Dynamic C includes several sample programs. Loading, executing and studying these programs will give you a solid hands-on overview of the RCM3200's capabilities, as well as a quick start using Dynamic C as an application development tool.

NOTE: The sample programs assume that you have at least an elementary grasp of the C programming language. If you do not, see the introductory pages of the *Dynamic C User's Manual* for a suggested reading list.

Complete information on Dynamic C is provided in the *Dynamic C User's Manual*.

In order to run the sample programs discussed in this chapter and elsewhere in this manual,

1. Your RCM3200 module must be plugged in to the Prototyping Board as described in Chapter 2, "Hardware Setup."
2. Dynamic C must be installed and running on your PC.
3. The RCM3200 module must be connected to your PC through the serial programming cable.
4. Power must be applied to the RCM3200 through the Prototyping Board.

Refer to Chapter 2, "Hardware Setup," if you need further information on these steps.

If you are using an RCM3200 or RCM3220, remember to allow the compiler to run the application in the program execution SRAM by selecting **Code and BIOS in Flash, Run in RAM** from the Dynamic C **Options > Project Options > Compiler** menu.

To run a sample program, open it with the **File** menu, then press function key **F9** to compile and run the program.

Complete information on Dynamic C is provided in the *Dynamic C User's Manual*.

3.2 Sample Programs

Of the many sample programs included with Dynamic C, several are specific to the RCM3200. Sample programs illustrating the general operation of the RCM3200, and serial communication are provided in the `SAMPLES\RCM3200` folder. Each sample program has comments that describe the purpose and function of the program. Follow the instructions at the beginning of the sample program.

- **CONTROLLED.C**—uses the **STDIO** window to demonstrate digital outputs by toggling LEDs DS1 and DS2 on the Prototyping Board on and off.

Parallel Port G bit 6 = LED DS1

Parallel Port G bit 7 = LED DS2

Once you have compiled and run this program, you will be prompted via the Dynamic C **STDIO** window to select LED DS1 or DS2. Use your PC keyboard to make your selection.

Once you have selected the LED, you will be prompted to select to turn the LED either ON or OFF. A logic low will light up the LED you selected.

- **FLASHLED1.C**—demonstrates the use of costatements to flash LEDs DS1 and DS2 on the Prototyping Board at different rates. Once you have compiled and run this program, LEDs DS1 and DS2 will flash on/off at different rates.
- **FLASHLED2.C**—demonstrates the use of cofunctions and costatements to flash LEDs DS1 and DS2 on the Prototyping Board at different rates. Once you have compiled and run this program, LEDs DS1 and DS2 will flash on/off at different rates.
- **TOGGLESWITCH.C**—demonstrates the use of costatements to detect switches using the press-and-release method of debouncing. LEDs DS1 and DS2 on the Prototyping Board are turned on and off when you press switches S2 and S3.
- **IR_DEMO.C**—Demonstrates sending Modbus ASCII packets between two Prototyping Board assemblies via the IrDA transceivers with the IrDA transceivers facing each other. Note that this sample program will only work with the RCM30/31/32XX Prototyping Board.

First, compile and run this program on one Prototyping Board assembly, then remove the programming cable and press the **RESET** button on the Prototyping Board so that the first RabbitCore module is operating in the **Run** mode. Then connect the programming cable to the second Prototyping Board assembly with the RCM3200 and compile and run the same sample program. With the programming cable still connected to the second Prototyping Board assembly, press switch S2 on the second Prototyping Board to transmit a packet. Once the first Prototyping Board assembly receives a test packet, it will send back a response packet that will be displayed in the Dynamic C **STDIO** window. The test packets and response packets have different codes.

Once you have loaded and executed these five programs and have an understanding of how Dynamic C and the RCM3200 modules interact, you can move on and try the other sample programs, or begin building your own.

3.2.1 Serial Communication

The following sample programs can be found in the `SAMPLES\RCM3200\SERIAL` folder.

- **FLOWCONTROL.C**—This program demonstrates hardware flow control by configuring Serial Port C (PC3/PC2) for CTS/RTS with serial data coming from TxB at 115,200 bps. One character at a time is received and is displayed in the **STDIO** window.

To set up the Prototyping Board, you will need to tie TxB and RxB together on the RS-232 header at J5, and you will also tie TxC and RxC together using the jumpers supplied in the Development Kit as shown in the diagram.

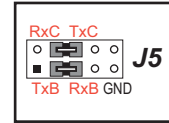

A repeating triangular pattern should print out in the **STDIO** window.

The program will periodically switch flow control on or off to demonstrate the effect of no flow control.

- **PARITY.C**—This program demonstrates the use of parity modes by repeatedly sending byte values 0–127 from Serial Port B to Serial Port C. The program will switch between generating parity or not on Serial Port B. Serial Port C will always be checking parity, so parity errors should occur during every other sequence.

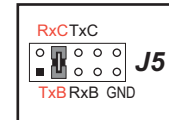

To set up the Prototyping Board, you will need to tie TxB and RxC together on the RS-232 header at J5 using the jumpers supplied in the Development Kit as shown in the diagram.

The Dynamic C **STDIO** window will display the error sequence.

- **SIMPLE3WIRE.C**—This program demonstrates basic RS-232 serial communication. Lower case characters are sent by TxC, and are received by RxB. The characters are converted to upper case and are sent out by TxB, are received by RxC, and are displayed in the Dynamic C **STDIO** window.

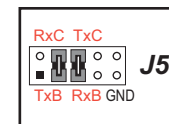

To set up the Prototyping Board, you will need to tie TxB and RxC together on the RS-232 header at J5, and you will also tie RxB and TxC together using the jumpers supplied in the Development Kit as shown in the diagram.

- **SIMPLE5WIRE.C**—This program demonstrates 5-wire RS-232 serial communication with flow control on Serial Port C and data flow on Serial Port B.

To set up the Prototyping Board, you will need to tie TxB and RxB together on the RS-232 header at J5, and you will also tie TxC and RxC together using the jumpers supplied in the Development Kit as shown in the diagram.

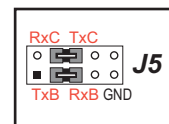

Once you have compiled and run this program, you can test flow control by disconnecting TxC from RxC while the program is running. Characters will no longer appear in the **STDIO** window, and will display again once TxC is connected back to RxC.

- **SWITCHCHAR.C**—This program demonstrates transmitting and then receiving an ASCII string on Serial Ports B and C. It also displays the serial data received from both ports in the **STDIO** window.

To set up the Prototyping Board, you will need to tie TxB and RxC together on the RS-232 header at J5, and you will also tie RxB and TxC together using the jumpers supplied in the Development Kit as shown in the diagram.

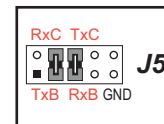

Once you have compiled and run this program, press and release S2 and S3 on the Prototyping Board. The data sent between the serial ports will be displayed in the **STDIO** window.

Two sample programs, **SIMPLE485MASTER.C** and **SIMPLE485SLAVE.C**, are available to illustrate RS-485 master/slave communication. To run these sample programs, you will need a second Rabbit-based system with RS-485, and you will also have to add an RS-485 transceiver such as the SP483E and bias resistors to the RCM30/31/32XX Prototyping Board.

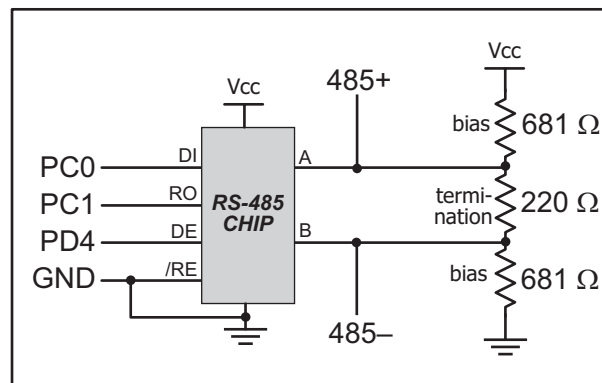

The diagram shows the connections. You will have to connect PC0 and PC1 (Serial Port D) on the RCM30/31/32XX Prototyping Board to the RS-485 transceiver, and you will connect PD4 to the RS-485 transceiver to enable or disable the RS-485 transmitter.

The RS-485 connections between the slave and master devices are as follows.

- RS485+ to RS485+
- RS485- to RS485-
- GND to GND
- **SIMPLE485MASTER.C**—This program demonstrates a simple RS-485 transmission of lower case letters to a slave RCM3200. The slave will send back converted upper case letters back to the master RCM3200 and display them in the **STDIO** window. Use **SIMPLE485SLAVE.C** to program the slave RCM3200.
- **SIMPLE485SLAVE.C**—This program demonstrates a simple RS-485 transmission of lower case letters to a master RCM3200. The slave will send back converted upper case letters back to the master RCM3200 and display them in the **STDIO** window. Use **SIMPLE485MASTER.C** to program the master RCM3200.

3.2.2 Other Sample Programs

Section 6.5 describes the TCP/IP sample programs, and Appendix C.8 provides sample programs for the optional LCD/keypad module that can be installed on the Prototyping Board.

4. HARDWARE REFERENCE

Chapter 4 describes the hardware components and principal hardware subsystems of the RCM3200. Appendix A, “RCM3200 Specifications,” provides complete physical and electrical specifications.

Figure 5 shows these Rabbit-based subsystems designed into the RCM3200.

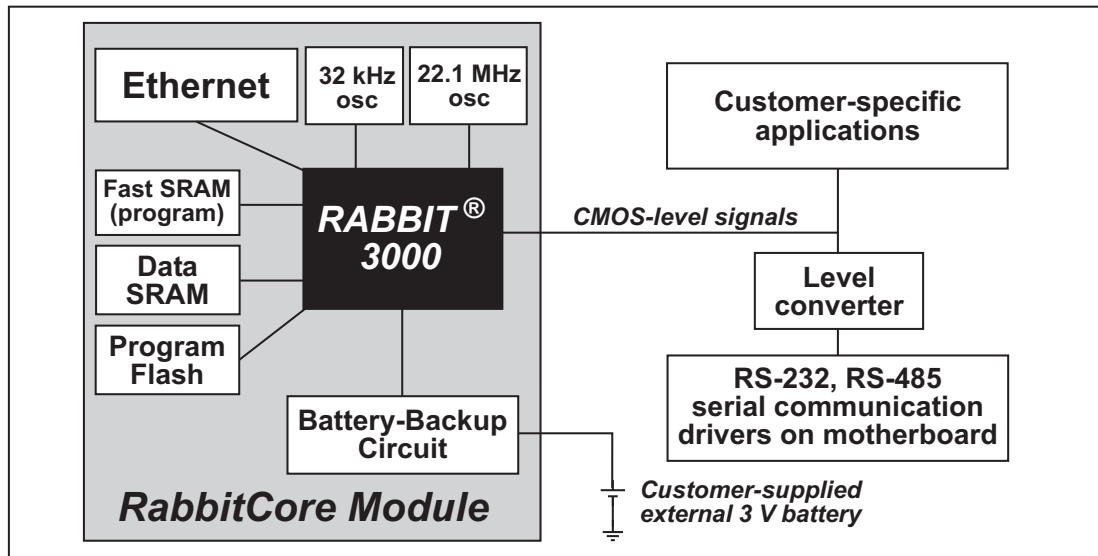

Figure 5. RCM3200 Subsystems

4.1 RCM3200 Digital Inputs and Outputs

The RCM3200 has 52 parallel I/O lines grouped in seven 8-bit ports available on headers J1 and J2. The 44 bidirectional I/O lines are located on pins PA0–PA7, PB0, PB2–PB7, PD2–PD7, PE0–PE1, PE3–PE7, PF0–PF7, and PG0–PG7.

Figure 6 shows the RCM3200 pinouts for headers J1 and J2.

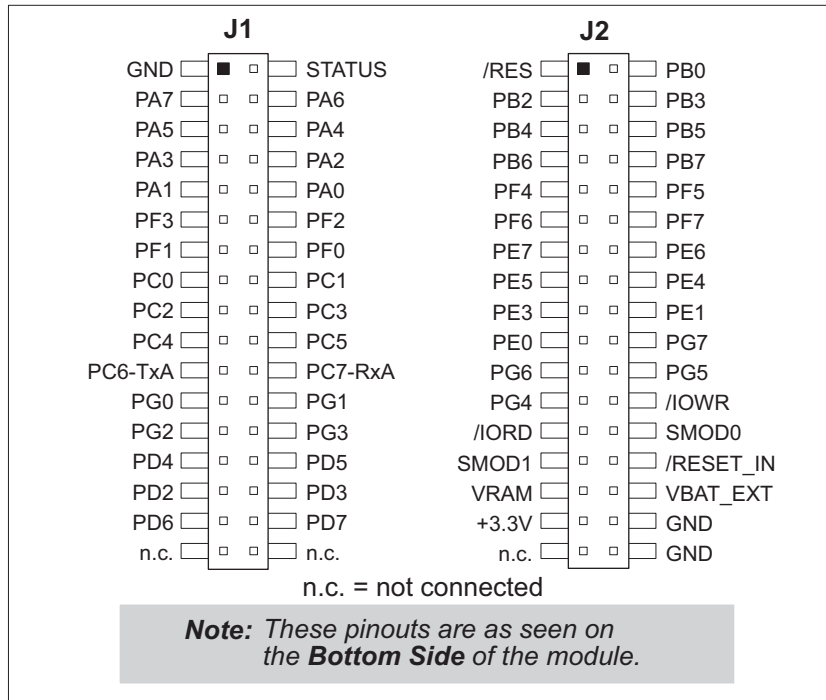

Figure 6. RCM3200 Pinouts

The pinouts for the RCM3000, RCM3100, and RCM3200 are compatible. Visit the [Web site](#) for further information.

Headers J1 and J2 are standard 2×34 headers with a nominal 2 mm pitch. An RJ-45 Ethernet jack is also included with the RCM3200 series.

The signals labeled PD2, PD3, PD6, and PD7 on header J1 (pins 29–32) and the pins that are not connected (pins 33–34 on header J1 and pin 33 on header J2) are reserved for future use.

Figure 7 shows the use of the Rabbit 3000 microprocessor ports in the RCM3200 modules.

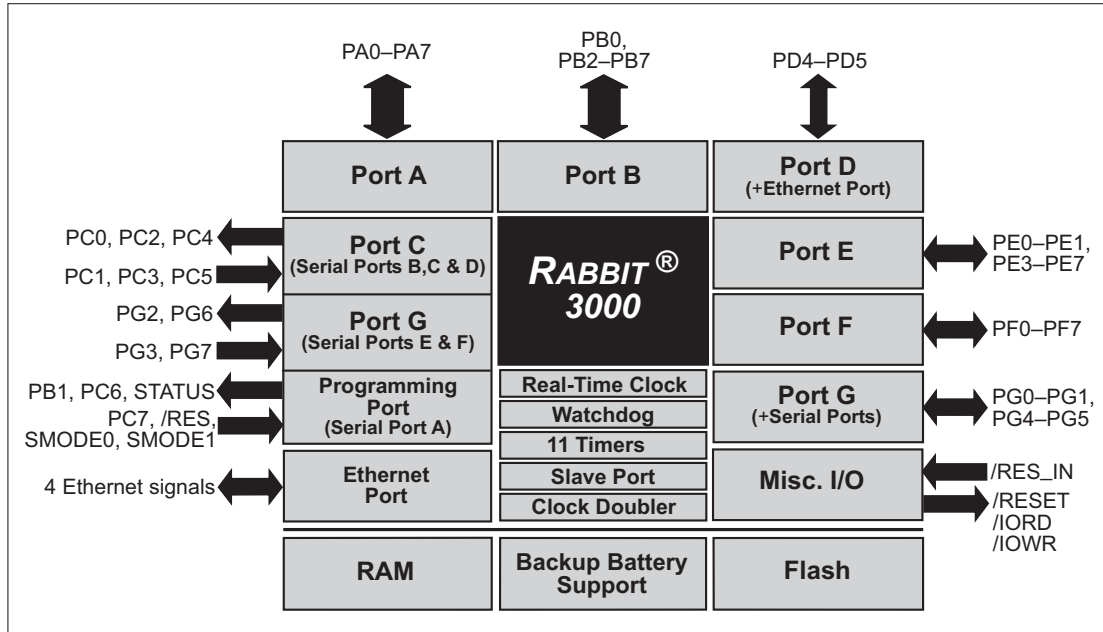

Figure 7. Use of Rabbit 3000 Ports

The ports on the Rabbit 3000 microprocessor used in the RCM3200 are configurable, and so the factory defaults can be reconfigured. Table 2 lists the Rabbit 3000 factory defaults and the alternate configurations.

Table 2. RCM3200 Pinout Configurations

Pin	Pin Name	Default Use	Alternate Use	Notes
1	GND			
2	STATUS	Output (Status)	Output	
3–10	PA[7:0]	Parallel I/O	External data bus (ID0–ID7) Slave port data bus (SD0–SD7)	
11	PF3	Input/Output	QD2A	
12	PF2	Input/Output	QD2B	
13	PF1	Input/Output	QD1A CLKC	
14	PF0	Input/Output	QD1B CLKD	
15	PC0	Output	TXD	Serial Port D
16	PC1	Input	RXD	
17	PC2	Output	TXC	Serial Port C
18	PC3	Input	RXC	
19	PC4	Output	TXB	Serial Port B
20	PC5	Input	RXB	
21	PC6	Output	TXA	Serial Port A (programming port)
22	PC7	Input	RXA	
23	PG0	Input/Output	TCLKF	Serial Clock F output
24	PG1	Input/Output	RCLKF	Serial Clock F input
25	PG2	Input/Output	TXF	Serial Port F
26	PG3	Input/Output	RXF	
27	PD4	Input/Output	ATXB	
28	PD5	Input/Output	ARXB	
29	PD2	Input/Output	TPOUT– *	Ethernet transmit port
30	PD3	Input/Output	TPOUT+ *	
31	PD6	Input/Output	TPIN– *	Ethernet receive port
32	PD7	Input/Output	TPIN+ *	
33	LNK_OUT	Output		Max. current draw 1 mA (see Note 1)
34	ACT_OUT	Output		

* Pins 29–32 are reserved for future use.

Table 2. RCM3200 Pinout Configurations (continued)

Pin	Pin Name	Default Use	Alternate Use	Notes	
Header J2	1	/RES	Reset output	Reset input	Reset output from Reset Generator
	2	PB0	Input/Output	CLKB	
	3	PB2	Input/Output	IA0 /SWR	External Address 0 Slave port write
	4	PB3	Input/Output	IA1 /SRD	External Address 1 Slave port read
	5	PB4	Input/Output	IA2 SA0	External Address 2 Slave port Address 0
	6	PB5	Input/Output	IA3 SA1	External Address 3 Slave port Address 1
	7	PB6	Input/Output	IA4	External Address 4
	8	PB7	Input/Output	IA5 /SLAVEATTN	External Address 5 Slave Attention
	9	PF4	Input/Output	AQD1B PWM0	
	10	PF5	Input/Output	AQD1A PWM1	
	11	PF6	Input/Output	AQD2B PWM2	
	12	PF7	Input/Output	AQD2A PWM3	
	13	PE7	Input/Output	I7 /SCS	
	14	PE6	Input/Output	I6	
	15	PE5	Input/Output	I5 INT1B	
	16	PE4	Input/Output	I4 INT0B	
	17	PE3	Input/Output	I3	
	18	PE1	Input/Output	I1 INT1A	I/O Strobe 1 Interrupt 1A
	19	PE0	Input/Output	I0 INT0A	I/O Strobe 0 Interrupt 0A

Table 2. RCM3200 Pinout Configurations (continued)

Pin	Pin Name	Default Use	Alternate Use	Notes	
Header J2	20	PG7	Input/Output	RXE	Serial Port E
	21	PG6	Input/Output	TXE	
	22	PG5	Input/Output	RCLKE	Serial Clock E input
	23	PG4	Input/Output	TCLKE	Serial Clock E output
	24	/IOWR	Output		External write strobe
	25	/IORD	Output		External read strobe
	26–27	SMODE0, SMODE1	(0,0)—start executing at address zero (0,1)—cold boot from slave port (1,0)—cold boot from clocked Serial Port A SMODE0 =1, SMODE1 = 1 Cold boot from asynchronous Serial Port A at 2400 bps (programming cable connected)		Also connected to programming cable
	28	/RESET_IN	Input		Input to Reset Generator
	29	VRAM	Output		See Notes below table
	30	VBAT_EXT	3 V battery Input		Minimum battery voltage 2.85 V
	31	+3.3V	Input		3.15–3.45 V DC
	32	GND			
	33	n.c.			Reserved for future use
	34	GND			

Notes

1. When using pins 33–34 on header J1 to drive LEDs, you must use an external buffer to drive these external LEDs. These pins are not connected on the RCM3220, which does not have the LEDs installed.
2. The VRAM voltage is temperature-dependent. If the VRAM voltage drops below about 1.2 V to 1.5 V, the contents of the battery-backed SRAM may be lost. If VRAM drops below 1.0 V, the 32 kHz oscillator could stop running. Pay careful attention to this voltage if you draw any current from this pin.

Locations R45, R46, R53, R57, and R74 allow the population of 0 Ω resistors (jumpers) that will be used to enable future options. These locations are currently unused.

4.1.1 Memory I/O Interface

The Rabbit 3000 address lines (A0–A19) and all the data lines (D0–D7) are routed internally to the onboard flash memory and SRAM chips. I/O write (/IOWR) and I/O read (/IORD) are available for interfacing to external devices.

Parallel Port A can also be used as an external I/O data bus to isolate external I/O from the main data bus. Parallel Port B pins PB2–PB7 can also be used as an auxiliary address bus.

When using the external I/O bus, you must add the following line at the beginning of your program.

```
#define PORTA_AUX_IO    // required to enable external I/O bus
```

The STATUS output has three different programmable functions:

3. It can be driven low on the first op code fetch cycle.
4. It can be driven low during an interrupt acknowledge cycle.
5. It can also serve as a general-purpose output.

4.1.2 Other Inputs and Outputs

Two status mode pins, SMODE0 and SMODE1, are available as inputs. The logic state of these two pins determines the startup procedure after a reset.

/RESET_IN is an external input used to reset the Rabbit 3000 microprocessor and the RCM3200 memory. /RES is an output from the reset circuitry that can be used to reset other peripheral devices.

4.1.3 5 V Tolerant Inputs

The RCM3200 operates over a voltage from 3.15 V to 3.45 V, but most RCM3200 input pins, except /RESET_IN, VRAM, VBAT_EXT, and the power-supply pins, are 5 V tolerant. When a 5 V signal is applied to 5 V tolerant pins, they present a high impedance even if the Rabbit power is off. The 5 V tolerant feature allows 5 V devices that have a suitable switching threshold to be connected directly to the RCM3200. This includes HCT family parts operated at 5 V that have an input threshold between 0.8 and 2 V.

NOTE: CMOS devices operated at 5 V that have a threshold at 2.5 V are not suitable for direct connection because the Rabbit 3000 outputs do not rise above VDD, and is often specified as 3.3 V. Although a CMOS input with a 2.5 V threshold may switch at 3.3 V, it will consume excessive current and switch slowly.

In order to translate between 5 V and 3.3 V, HCT family parts powered from 5 V can be used, and are often the best solution. There is also the “LVT” family of parts that operate from 2.0 V to 3.3 V, but that have 5 V tolerant inputs and are available from many suppliers. True level-translating parts are available with separate 3.3 V and 5 V supply pins, but these parts are not usually needed, and have design traps involving power sequencing.

4.2 Serial Communication

The RCM3200 board does not have an RS-232 or an RS-485 transceiver directly on the board. However, an RS-232 or RS-485 interface may be incorporated on the board the RCM3200 is mounted on. For example, the Prototyping Board has a standard RS-232 transceiver chip.

4.2.1 Serial Ports

There are six serial ports designated as Serial Ports A, B, C, D, E, and F. All six serial ports can operate in an asynchronous mode up to the baud rate of the system clock divided by 8. An asynchronous port can handle 7 or 8 data bits. A 9th bit address scheme, where an additional bit is sent to mark the first byte of a message, is also supported. Serial Ports A, B, C, and D can also be operated in the clocked serial mode. In this mode, a clock line synchronously clocks the data in or out. Either of the two communicating devices can supply the clock. When the Rabbit 3000 provides the clock, the baud rate can be up to 80% of the system clock frequency divided by 128, or 276,250 bps for a 44.2 MHz clock speed.

Serial Ports E and F can also be configured as SDLC/HDLC serial ports. The IrDA protocol is also supported in SDLC format by these two ports.

Serial Port A is available only on the programming port.

4.2.2 Ethernet Port (RCM3200 only)

Figure 8 shows the pinout for the RJ-45 Ethernet port (J4). Note that some Ethernet connectors are numbered in reverse to the order used here.

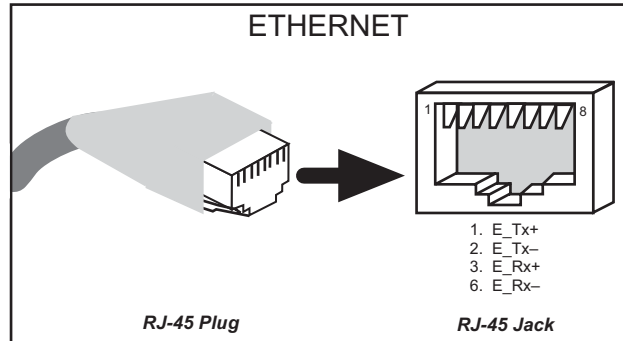

Figure 8. RJ-45 Ethernet Port Pinout

Three LEDs are placed next to the RJ-45 Ethernet jack, one to indicate an Ethernet link (**LNK**), one to indicate Ethernet activity (**ACT**), and one to indicate when the RCM3200 is connected to a functioning 100Base-T network (**SPD**).

The transformer/connector assembly ground is connected to the RCM3200 printed circuit board digital ground via a ferrite bead, R42, as shown in Figure 9.

The RJ-45 connector is shielded to minimize EMI effects to/from the Ethernet signals.

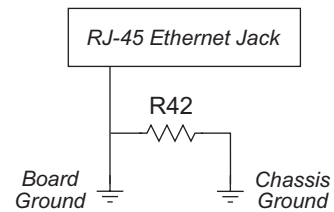

Figure 9. Isolation Resistor R42

4.2.3 Serial Programming Port

The RCM3200 serial programming port is accessed using header J3 or over an Ethernet connection via the RabbitLink EG2110. The programming port uses the Rabbit 3000's Serial Port A for communication. Dynamic C uses the programming port to download and debug programs.

The programming port is also used for the following operations.

- Cold-boot the Rabbit 3000 on the RCM3200 after a reset.
- Remotely download and debug a program over an Ethernet connection using the RabbitLink EG2110.
- Fast copy designated portions of flash memory from one Rabbit-based board (the master) to another (the slave) using the Rabbit Cloning Board.

In addition to Serial Port A, the Rabbit 3000 startup-mode (SMODE0, SMODE1), status, and reset pins are available on the programming port.

The two startup mode pins determine what happens after a reset—the Rabbit 3000 is either cold-booted or the program begins executing at address 0x0000.

The status pin is used by Dynamic C to determine whether a Rabbit microprocessor is present. The status output has three different programmable functions:

1. It can be driven low on the first op code fetch cycle.
2. It can be driven low during an interrupt acknowledge cycle.
3. It can also serve as a general-purpose CMOS output.

The /RESET_IN pin is an external input that is used to reset the Rabbit 3000 and the RCM3200/RCM3220 onboard peripheral circuits. The serial programming port can be used to force a hard reset on the RCM3200/RCM3220 by asserting the /RESET_IN signal.

Alternate Uses of the Serial Programming Port

All three clocked Serial Port A signals are available as

- a synchronous serial port
- an asynchronous serial port, with the clock line usable as a general CMOS I/O pin

The programming port may also be used as a serial port once the application is running. The SMODE pins may then be used as inputs and the status pin may be used as an output.

Refer to the *Rabbit 3000 Microprocessor User's Manual* for more information.

4.3 Serial Programming Cable

The programming cable is used to connect the serial programming port of the RCM3200 to a PC serial COM port. The programming cable converts the RS-232 voltage levels used by the PC serial port to the CMOS voltage levels used by the Rabbit 3000.

When the **PROG** connector on the programming cable is connected to the RCM3200 serial programming port at header J3, programs can be downloaded and debugged over the serial interface.

The **DIAG** connector of the programming cable may be used on header J3 of the RCM3200 with the RCM3200 operating in the Run Mode. This allows the programming port to be used as a regular serial port.

4.3.1 Changing Between Program Mode and Run Mode

The RCM3200 is automatically in Program Mode when the **PROG** connector on the programming cable is attached, and is automatically in Run Mode when no programming cable is attached. When the Rabbit 3000 is reset, the operating mode is determined by the state of the SMODE pins. When the programming cable's **PROG** connector is attached, the SMODE pins are pulled high, placing the Rabbit 3000 in the Program Mode. When the programming cable's **PROG** connector is not attached, the SMODE pins are pulled low, causing the Rabbit 3000 to operate in the Run Mode.

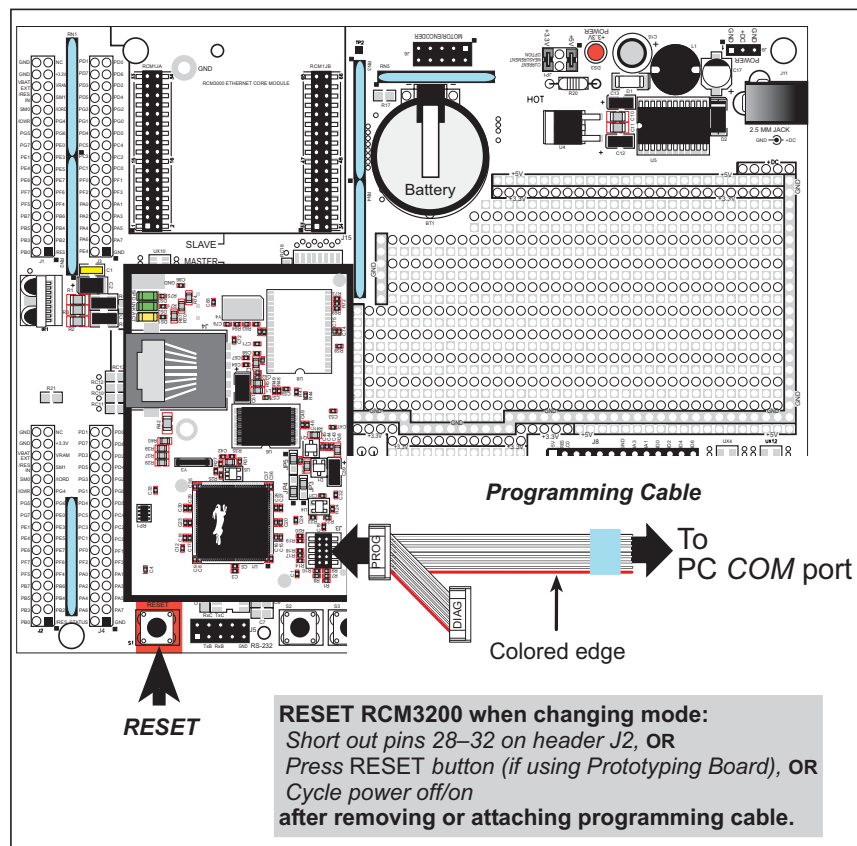

Figure 10. Switching Between Program Mode and Run Mode

A program “runs” in either mode, but can only be downloaded and debugged when the RCM3200 is in the Program Mode.

Refer to the *Rabbit 3000 Microprocessor User’s Manual* for more information on the programming port.

4.3.2 Standalone Operation of the RCM3200

The RCM3200 must be programmed via the Prototyping Board or via a similar arrangement on a customer-supplied board. Once the RCM3200 has been programmed successfully, remove the serial programming cable from the programming connector and reset the RCM3200. The RCM3200 may be reset by cycling the power off/on or by pressing the **RESET** button on the Prototyping Board. The RCM3200 module may now be removed from the Prototyping Board for end-use installation.

CAUTION: Disconnect power to the Prototyping Board or other boards when removing or installing your RCM3200 module to protect against inadvertent shorts across the pins or damage to the RCM3200 if the pins are not plugged in correctly. Do not reapply power until you have verified that the RCM3200 module is plugged in correctly.

4.4 Other Hardware

4.4.1 Clock Doubler

The RCM3200 takes advantage of the Rabbit 3000 microprocessor's internal clock doubler. A built-in clock doubler allows half-frequency crystals to be used to reduce radiated emissions. The 44.2 MHz frequency specified for the RCM3200 and the RCM3220 is generated using a 22.12 MHz resonator.

The clock doubler may be disabled if 44.2 MHz clock speeds are not required. Disabling the Rabbit 3000 microprocessor's internal clock doubler will reduce power consumption and further reduce radiated emissions. The clock doubler is disabled with a simple configuration macro as shown below.

1. Select the “Defines” tab from the Dynamic C **Options > Project Options** menu.
2. Add the line `CLOCK_DOUBLED=0` to always disable the clock doubler.

The clock doubler is enabled by default, and usually no entry is needed. If you need to specify that the clock doubler is always enabled, add the line `CLOCK_DOUBLED=1` to always enable the clock doubler.

3. Click **OK** to save the macro. The clock doubler will now remain off whenever you are in the project file where you defined the macro.

4.4.2 Spectrum Spreader

The Rabbit 3000 features a spectrum spreader, which helps to mitigate EMI problems. By default, the spectrum spreader is on automatically, but it may also be turned off or set to a stronger setting. The means for doing so is through a simple configuration macro as shown below.

1. Select the “Defines” tab from the Dynamic C **Options > Project Options** menu.
2. Normal spreading is the default, and usually no entry is needed. If you need to specify normal spreading, add the line

```
ENABLE_SPREADER=1
```

For strong spreading, add the line

```
ENABLE_SPREADER=2
```

To disable the spectrum spreader, add the line

```
ENABLE_SPREADER=0
```

NOTE: The strong spectrum-spreading setting is unnecessary for the RCM3200.

3. Click **OK** to save the macro. The spectrum spreader will now be set to the state specified by the macro value whenever you are in the project file where you defined the macro.

NOTE: Refer to the *Rabbit 3000 Microprocessor User's Manual* for more information on the spectrum-spreading setting and the maximum clock speed.

4.5 Memory

4.5.1 SRAM

The RCM3200 and the RCM3220 have 512K of program execution SRAM installed at U8. The RCM3200 and RCM3220 data SRAM installed at U6 is 256K, and the RCM3210 has 128K data SRAM installed at U6..

4.5.2 Flash EPROM

The RCM3200 is also designed to accept 256K to 512K of flash EPROM at U7.

NOTE: Rabbit recommends that any customer applications should not be constrained by the sector size of the flash EPROM since it may be necessary to change the sector size in the future.

Writing to arbitrary flash memory addresses at run time is also discouraged. Instead, define a “user block” area to store persistent data. The functions `writeUserBlock()` and `readUserBlock()` are provided for this. Refer to the *Rabbit 3000 Microprocessor Designer’s Handbook* and the *Dynamic C Function Reference Manual* for additional information.

A Flash Memory Bank Select jumper configuration option based on 0 Ω surface-mounted resistors exists at header JP4 on the RCM3200 RabbitCore modules. This option, used in conjunction with some configuration macros, allows Dynamic C to compile two different co-resident programs for the upper and lower halves of a 256K flash in such a way that both programs start at logical address 0000. This option is not relevant to the RCM3200 RabbitCore modules, which use 512K flash memories.

4.5.3 Dynamic C BIOS Source Files

The Dynamic C BIOS source files handle different standard RAM and flash EPROM sizes automatically.

5. SOFTWARE REFERENCE

Dynamic C is an integrated development system for writing embedded software. It runs on an IBM-compatible PC and is designed for use with Rabbit controllers and other controllers based on the Rabbit microprocessor. Chapter 4 provides the libraries and function calls related to the RCM3200.

5.1 More About Dynamic C

Dynamic C has been in use worldwide since 1989. It is specially designed for programming embedded systems, and features quick compile and interactive debugging in the real environment. A complete reference guide to Dynamic C is contained in the *Dynamic C User's Manual*.

You have a choice of doing your software development in the flash memory or in the data SRAM included on the RCM3200. The flash memory and SRAM options are selected with the **Options > Project Options > Compiler** menu.

The advantage of working in RAM is to save wear on the flash memory, which is limited to about 100,000 write cycles. The disadvantage is that the code and data might not both fit in RAM.

NOTE: An application should be run from the program execution SRAM after the programming cable is disconnected. Your final code must always be stored in flash memory for reliable operation. For RCM3200 modules running at 44.2 MHz, which have a fast program execution SRAM that is not battery-backed, you should select **Code and BIOS in Flash, Run in RAM** from the Dynamic C **Options > Project Options > Compiler** menu to store the code in flash and copy it to the fast program execution SRAM at run-time to take advantage of the faster clock speed. This option optimizes the performance of RCM3200 modules running at 44.2 MHz.

NOTE: Do not depend on the flash memory sector size or type. Due to the volatility of the flash memory market, the RCM3200 and Dynamic C were designed to accommodate flash devices with various sector sizes.

Developing software with Dynamic C is simple. Users can write, compile, and test C and assembly code without leaving the Dynamic C development environment. Debugging occurs while the application runs on the target. Alternatively, users can compile a program to an image file for later loading. Dynamic C runs on PCs under Windows 2000 and later—see Rabbit's Technical Note TN257, *Running Dynamic C® With Windows Vista®*,

for additional information if you are using a Dynamic C release prior to v. 9.60 under Windows Vista. Programs can be downloaded at baud rates of up to 460,800 bps after the program compiles.

Dynamic C has a number of standard features.

- Full-feature source and/or assembly-level debugger, no in-circuit emulator required.
- Royalty-free TCP/IP stack with source code and most common protocols.
- Hundreds of functions in source-code libraries and sample programs:
 - ▶ Exceptionally fast support for floating-point arithmetic and transcendental functions.
 - ▶ RS-232 and RS-485 serial communication.
 - ▶ Analog and digital I/O drivers.
 - ▶ I²C, SPI, GPS, file system.
 - ▶ LCD display and keypad drivers.
- Powerful language extensions for cooperative or preemptive multitasking
- Loader utility program to load binary images into Rabbit targets in the absence of Dynamic C.
- Provision for customers to create their own source code libraries and augment on-line help by creating “function description” block comments using a special format for library functions.
- Standard debugging features:
 - ▶ Breakpoints—Set breakpoints that can disable interrupts.
 - ▶ Single-stepping—Step into or over functions at a source or machine code level, μ C/OS-II aware.
 - ▶ Code disassembly—The disassembly window displays addresses, opcodes, mnemonics, and machine cycle times. Switch between debugging at machine-code level and source-code level by simply opening or closing the disassembly window.
 - ▶ Watch expressions—Watch expressions are compiled when defined, so complex expressions including function calls may be placed into watch expressions. Watch expressions can be updated with or without stopping program execution.
 - ▶ Register window—All processor registers and flags are displayed. The contents of general registers may be modified in the window by the user.
 - ▶ Stack window—shows the contents of the top of the stack.
 - ▶ Hex memory dump—displays the contents of memory at any address.
 - ▶ **STDIO** window—`printf` outputs to this window and keyboard input on the host PC can be detected for debugging purposes. `printf` output may also be sent to a serial port or file.

5.2 Dynamic C Function Calls

5.2.1 Digital I/O

The RCM3200 was designed to interface with other systems, and so there are no drivers written specifically for the I/O. The general Dynamic C read and write functions allow you to customize the parallel I/O to meet your specific needs. For example, use

```
WrPortI(PEDDR, &PEDDRShadow, 0x00);
```

to set all the Port E bits as inputs, or use

```
WrPortI(PEDDR, &PEDDRShadow, 0xFF);
```

to set all the Port E bits as outputs.

When using the external I/O bus on the Rabbit 3000 chip, add the line

```
#define PORTA_AUX_IO // required to enable external I/O bus
```

to the beginning of any programs using the external I/O bus.

The sample programs in the Dynamic C **SAMPLES/RCM3200** directory provide further examples.

5.2.2 SRAM Use

The RCM3200 has a battery-backed data SRAM and a program-execution SRAM. Dynamic C provides the **protected** keyword to identify variables that are to be placed into the battery-backed SRAM. The compiler generates code that creates a backup copy of a protected variable before the variable is modified. If the system resets while the protected variable is being modified, the variable's value can be restored when the system restarts.

The sample code below shows how a protected variable is defined and how its value can be restored.

```
protected nf_device nandFlash;
int main() {
    ...
    _sysIsSoftReset(); // restore any protected variables
```

The **bbram** keyword may also be used instead if there is a need to store a variable in battery-backed SRAM without affecting the performance of the application program. Data integrity is *not* assured when a reset or power failure occurs during the update process.

Additional information on **bbram** and **protected** variables is available in the *Dynamic C User's Manual*.

5.2.3 Serial Communication Drivers

Library files included with Dynamic C provide a full range of serial communications support. The `RS232.LIB` library provides a set of circular-buffer-based serial functions. The `PACKET.LIB` library provides packet-based serial functions where packets can be delimited by the 9th bit, by transmission gaps, or with user-defined special characters. Both libraries provide blocking functions, which do not return until they are finished transmitting or receiving, and nonblocking functions, which must be called repeatedly until they are finished. For more information, see the *Dynamic C Function Reference Manual* and Technical Note 213, *Rabbit 2000 Serial Port Software*.

5.2.4 TCP/IP Drivers

The TCP/IP drivers are located in the `TCPIP` directory.

Complete information on these libraries and the TCP/IP functions is provided in the *Dynamic C TCP/IP User's Manual*.

5.2.5 Prototyping Board Function Calls

The functions described in this section are for use with the Prototyping Board features. The source code is in the `RCM32xx.LIB` library in the Dynamic C `SAMPLES\RCM3200` folder if you need to modify it for your own board design.

Other generic functions applicable to all devices based on Rabbit microprocessors are described in the *Dynamic C Function Reference Manual*.

5.2.5.1 Board Initialization

```
void brdInit (void);
```

Call this function at the beginning of your program. This function initializes Parallel Ports A through G for use with the RCM3200 Prototyping Board.

Summary of Initialization

1. I/O port pins are configured for Prototyping Board operation.
2. Unused configurable I/O are set as high outputs.
3. Only one RabbitCore module is plugged in, and is in the **MASTER** position on the Prototyping Board.
3. The LCD/keypad module is disabled.
4. RS-485 is not enabled.
5. RS-232 is not enabled.
6. The IrDA transceiver is disabled.
7. LEDs are off.

RETURN VALUE

None.

5.3 Upgrading Dynamic C

Dynamic C patches that focus on bug fixes are available from time to time. Check the Web site www.rabbit.com/support/ for the latest patches, workarounds, and bug fixes.

The default installation of a patch or bug fix is to install the file in a directory (folder) different from that of the original Dynamic C installation. Rabbit recommends using a different directory so that you can verify the operation of the patch without overwriting the existing Dynamic C installation. If you have made any changes to the BIOS or to libraries, or if you have programs in the old directory (folder), make these same changes to the BIOS or libraries in the new directory containing the patch. Do *not* simply copy over an entire file since you may overwrite a bug fix; of course, you may copy over any programs you have written.

5.3.1 Extras

Dynamic C installations are designed for use with the board they are included with, and are included at no charge as part of our low-cost kits.

Starting with Dynamic C version 9.60, Dynamic C includes the popular μ C/OS-II real-time operating system, point-to-point protocol (PPP), FAT file system, RabbitWeb, and other select libraries. Rabbit also offers for purchase the Rabbit Embedded Security Pack featuring the Secure Sockets Layer (SSL) and a specific Advanced Encryption Standard (AES) library.

In addition to the Web-based technical support included at no extra charge, a one-year telephone-based technical support subscription is also available for purchase.

Visit our Web site at www.rabbit.com for further information and complete documentation.

6. USING THE TCP/IP FEATURES

6.1 TCP/IP Connections

Programming and development can be done with the RCM3200 RabbitCore modules without connecting the Ethernet port to a network. However, if you will be running the sample programs that use the Ethernet capability or will be doing Ethernet-enabled development, you should connect the RCM3200 module's Ethernet port at this time.

Before proceeding you will need to have the following items.

- If you don't have Ethernet access, you will need at least a 10Base-T Ethernet card (available from your favorite computer supplier) installed in a PC.
- Two RJ-45 straight through Ethernet cables and a hub, or an RJ-45 crossover Ethernet cable.

The Ethernet cables and a 10Base-T Ethernet hub are available from Rabbit in a TCP/IP tool kit. More information is available at www.rabbit.com.

NOTE: Although 10Base-T is the minimum required, 10/100Base-T or 100Base-T is recommended to allow you to work with the full speed capabilities of the RCM3200.

1. Connect the AC adapter and the programming cable as shown in Section 2.2.2, "Step 2 — Connect Programming Cable."

2. Ethernet Connections

There are four options for connecting the RCM3200 module to a network for development and runtime purposes. The first two options permit total freedom of action in selecting network addresses and use of the "network," as no action can interfere with other users. We recommend one of these options for initial development.

- **No LAN** — The simplest alternative for desktop development. Connect the RCM3200's Ethernet port directly to the PC's network interface card using an RJ-45 *crossover cable*. A crossover cable is a special cable that flips some connections between the two connectors and permits direct connection of two client systems. A standard RJ-45 network cable will not work for this purpose.
- **Micro-LAN** — Another simple alternative for desktop development. Use a small Ethernet 10Base-T hub and connect both the PC's network interface card and the RCM3200's Ethernet port to it, using standard network cables.

The following options require more care in address selection and testing actions, as conflicts with other users, servers and systems can occur:

- **LAN** — Connect the RCM3200's Ethernet port to an existing LAN, preferably one to which the development PC is already connected. You will need to obtain IP addressing information from your network administrator.
- **WAN** — The RCM3200 is capable of direct connection to the Internet and other Wide Area Networks, but exceptional care should be used with IP address settings and all network-related programming and development. We recommend that development and debugging be done on a local network before connecting a RabbitCore system to the Internet.

TIP: Checking and debugging the initial setup on a micro-LAN is recommended before connecting the system to a LAN or WAN.

The PC running Dynamic C through the serial port on the RCM3200 does not need to be the PC with the Ethernet card.

3. Apply Power

Plug in the AC adapter. The RCM3200 module is now ready to be used.

6.2 TCP/IP Primer on IP Addresses

Obtaining IP addresses to interact over an existing, operating, network can involve a number of complications, and must usually be done with cooperation from your ISP and/or network systems administrator. For this reason, it is suggested that the user begin instead by using a direct connection between a PC and the RCM3200 board using an Ethernet crossover cable or a simple arrangement with a hub. (A crossover cable should not be confused with regular straight through cables.)

In order to set up this direct connection, the user will have to use a PC without networking, or disconnect a PC from the corporate network, or install a second Ethernet adapter and set up a separate private network attached to the second Ethernet adapter. Disconnecting your PC from the corporate network may be easy or nearly impossible, depending on how it is set up. If your PC boots from the network or is dependent on the network for some or all of its disks, then it probably should not be disconnected. If a second Ethernet adapter is used, be aware that Windows TCP/IP will send messages to one adapter or the other, depending on the IP address and the binding order in Microsoft products. Thus you should have different ranges of IP addresses on your private network from those used on the corporate network. If both networks service the same IP address, then Windows may send a packet intended for your private network to the corporate network. A similar situation will take place if you use a dial-up line to send a packet to the Internet. Windows may try to send it via the local Ethernet network if it is also valid for that network.

The following IP addresses are set aside for local networks and are not allowed on the Internet: 10.0.0.0 to 10.255.255.255, 172.16.0.0 to 172.31.255.255, and 192.168.0.0 to 192.168.255.255.

The RCM3200 board uses a 10/100Base-T type of Ethernet connection, which is the most common scheme. The RJ-45 connectors are similar to U.S. style telephone connectors, are except larger and have 8 contacts.

An alternative to the direct connection using a crossover cable is a direct connection using a hub. The hub relays packets received on any port to all of the ports on the hub. Hubs are low in cost and are readily available. The RCM3200 board uses 10 Mbps or 100 Mbps Ethernet, so the hub or Ethernet adapter must be either a 10 Mbps unit or a 10/100 unit that adapts to either 10 or 100 Mbps.

In a corporate setting where the Internet is brought in via a high-speed line, there are typically machines between the outside Internet and the internal network. These machines include a combination of proxy servers and firewalls that filter and multiplex Internet traffic. In the configuration below, the RCM3200 board could be given a fixed address so any of the computers on the local network would be able to contact it. It may be possible to configure the firewall or proxy server to allow hosts on the Internet to directly contact the controller, but it would probably be easier to place the controller directly on the external network outside of the firewall. This avoids some of the configuration complications by sacrificing some security.

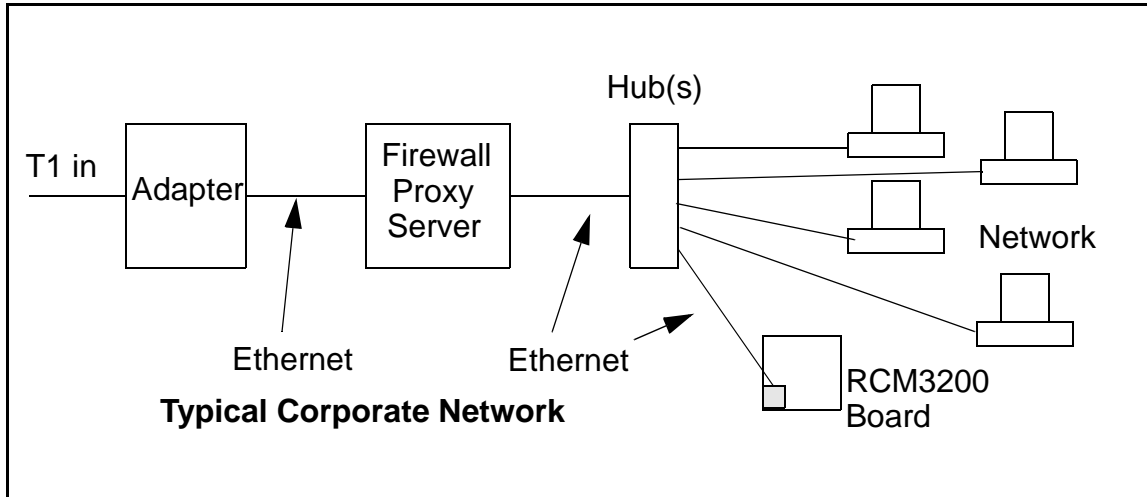

If your system administrator can give you an Ethernet cable along with its IP address, the netmask and the gateway address, then you may be able to run the sample programs without having to setup a direct connection between your computer and the RCM3200 board. You will also need the IP address of the nameserver, the name or IP address of your mail server, and your domain name for some of the sample programs.

6.2.1 IP Addresses Explained

IP (Internet Protocol) addresses are expressed as 4 decimal numbers separated by periods, for example:

216.103.126.155

10.1.1.6

Each decimal number must be between 0 and 255. The total IP address is a 32-bit number consisting of the 4 bytes expressed as shown above. A local network uses a group of adjacent IP addresses. There are always 2^N IP addresses in a local network. The netmask (also called subnet mask) determines how many IP addresses belong to the local network. The netmask is also a 32-bit address expressed in the same form as the IP address. An example netmask is:

255.255.255.0

This netmask has 8 zero bits in the least significant portion, and this means that 2^8 addresses are a part of the local network. Applied to the IP address above (216.103.126.155), this netmask would indicate that the following IP addresses belong to the local network:

216.103.126.0

216.103.126.1

216.103.126.2

etc.

216.103.126.254

216.103.126.255

The lowest and highest address are reserved for special purposes. The lowest address (216.102.126.0) is used to identify the local network. The highest address (216.102.126.255) is used as a broadcast address. Usually one other address is used for the address of the gateway out of the network. This leaves $256 - 3 = 253$ available IP addresses for the example given.

6.2.2 How IP Addresses are Used

The actual hardware connection via an Ethernet uses Ethernet adapter addresses (also called MAC addresses). These are 48-bit addresses and are unique for every Ethernet adapter manufactured. In order to send a packet to another computer, given the IP address of the other computer, it is first determined if the packet needs to be sent directly to the other computer or to the gateway. In either case, there is an IP address on the local network to which the packet must be sent. A table is maintained to allow the protocol driver to determine the MAC address corresponding to a particular IP address. If the table is empty, the MAC address is determined by sending an Ethernet broadcast packet to all devices on the local network asking the device with the desired IP address to answer with its MAC address. In this way, the table entry can be filled in. If no device answers, then the device is nonexistent or inoperative, and the packet cannot be sent.

IP addresses are arbitrary and can be allocated as desired provided that they don't conflict with other IP addresses. However, if they are to be used with the Internet, then they must be numbers that are assigned to your connection by proper authorities, generally by delegation via your service provider.

Each RCM3200 RabbitCore module has its own unique MAC address, which consists of the prefix 0090C2 followed by the code that appears on the label affixed to the RCM3200 module. For example, a MAC address might be 0090C2C002C0.

TIP: You can always verify the MAC address on your board by running the sample program `DISPLAY_MAC.C` from the `SAMPLES\TCPIP` folder.

6.2.3 Dynamically Assigned Internet Addresses

In many instances, there are no fixed IP addresses. This is the case when, for example, you are assigned an IP address dynamically by your dial-up Internet service provider (ISP) or when you have a device that provides your IP addresses using the Dynamic Host Configuration Protocol (DHCP). The RCM3200 RabbitCore modules can use such IP addresses to send and receive packets on the Internet, but you must take into account that this IP address may only be valid for the duration of the call or for a period of time, and could be a private IP address that is not directly accessible to others on the Internet. These private address can be used to perform some Internet tasks such as sending e-mail or browsing the Web, but usually cannot be used to participate in conversations that originate elsewhere on the Internet. If you want to find out this dynamically assigned IP address, under Windows XP you can run the `ipconfig` program while you are connected and look at the interface used to connect to the Internet.

Many networks use private IP addresses that are assigned using DHCP. When your computer comes up, and periodically after that, it requests its networking information from a DHCP server. The DHCP server may try to give you the same address each time, but a fixed IP address is usually not guaranteed.

If you are not concerned about accessing the RCM3200 from the Internet, you can place the RCM3200 on the internal network using a private address assigned either statically or through DHCP.

6.3 Placing Your Device on the Network

In many corporate settings, users are isolated from the Internet by a firewall and/or a proxy server. These devices attempt to secure the company from unauthorized network traffic, and usually work by disallowing traffic that did not originate from inside the network. If you want users on the Internet to communicate with your RCM3200, you have several options. You can either place the RCM3200 directly on the Internet with a real Internet address or place it behind the firewall. If you place the RCM3200 behind the firewall, you need to configure the firewall to translate and forward packets from the Internet to the RCM3200.

6.4 Running TCP/IP Sample Programs

We have provided a number of sample programs demonstrating various uses of TCP/IP for networking embedded systems. These programs require you to connect your PC and the RCM3200 board together on the same network. This network can be a local private network (preferred for initial experimentation and debugging), or a connection via the Internet.

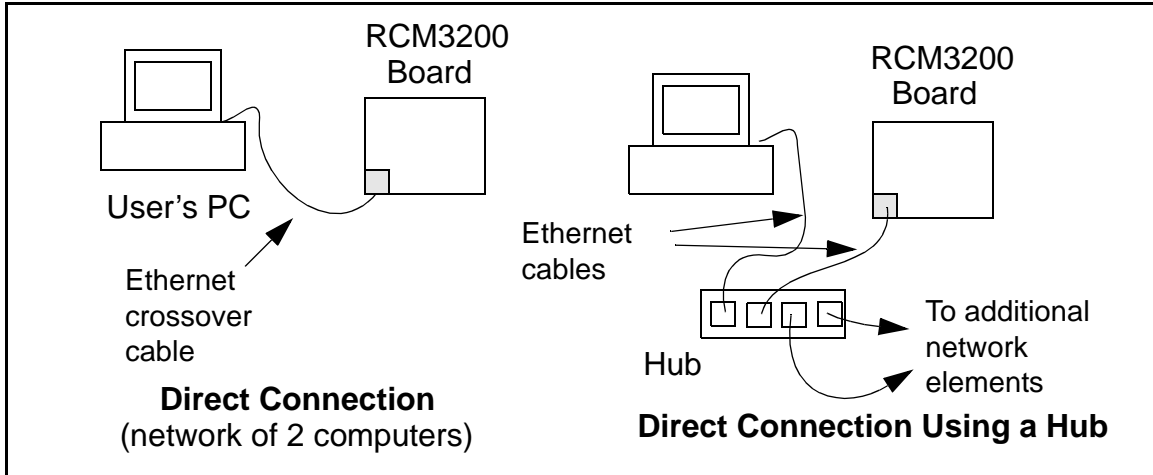

6.4.1 How to Set IP Addresses in the Sample Programs

With the introduction of Dynamic C 7.30 we have taken steps to make it easier to run many of our sample programs. Instead of the `MY_IP_ADDRESS` and other macros, you will see a `TCPCONFIG` macro. This macro tells Dynamic C to select your configuration from a list of default configurations. You will have three choices when you encounter a sample program with the `TCPCONFIG` macro.

1. You can replace the `TCPCONFIG` macro with individual `MY_IP_ADDRESS`, `MY_NETMASK`, `MY_GATEWAY`, and `MY_NAMESERVER` macros in each program.
2. You can leave `TCPCONFIG` at the usual default of 1, which will set the IP configurations to `10.10.6.100`, the netmask to `255.255.255.0`, and the nameserver and gateway to `10.10.6.1`. If you would like to change the default values, for example, to use an IP address of `10.1.1.2` for the RCM3200 board, and `10.1.1.1` for your PC, you can edit the values in the section that directly follows the “General Configuration” comment in the `TCP_CONFIG.LIB` library. You will find this library in the `LIB/TCPIP` directory.
3. You can create a `CUSTOM_CONFIG.LIB` library and use a `TCPCONFIG` value greater than 100. Instructions for doing this are at the beginning of the `TCP_CONFIG.LIB` file.

There are some other “standard” configurations for `TCPCONFIG` that let you select different features such as DHCP. Their values are documented at the top of the `TCP_CONFIG.LIB` library. More information is available in the *Dynamic C TCP/IP User’s Manual*.

IP Addresses Before Dynamic C 7.30

Most of the sample programs such as shown in the example below use macros to define the IP address assigned to the board and the IP address of the gateway, if there is a gateway.

```
#define MY_IP_ADDRESS "10.10.6.170"  
#define MY_NETMASK "255.255.255.0"  
#define MY_GATEWAY "10.10.6.1"  
#define MY_NAMESERVER "10.10.6.1"
```

In order to do a direct connection, the following IP addresses can be used for the RCM3200:

```
#define MY_IP_ADDRESS "10.1.1.2"  
#define MY_NETMASK "255.255.255.0"  
// #define MY_GATEWAY "10.10.6.1"  
// #define MY_NAMESERVER "10.10.6.1"
```

In this case, the gateway and nameserver are not used, and are commented out. The IP address of the board is defined to be `10.1.1.2`. The IP address of your PC can be defined as `10.1.1.1`.

6.4.2 How to Set Up your Computer's IP Address for Direct Connect

When your computer is connected directly to the RCM3200 board via an Ethernet connection, you need to assign an IP address to your computer. To assign the PC the address **10.10.6.101** with the netmask **255.255.255.0**, do the following.

Click on **Start > Settings > Control Panel** to bring up the Control Panel, and then double-click the Network icon. Depending on which version of Windows you are using, look for the **TCP/IP Protocol/Network > Dial-Up Connections/Network** line or tab. Double-click on this line or select **Properties** or **Local Area Connection > Properties** to bring up the TCP/IP properties dialog box. You can edit the IP address and the subnet mask directly. (Disable “obtain an IP address automatically.”) You may want to write down the existing values in case you have to restore them later. It is not necessary to edit the gateway address since the gateway is not used with direct connect.

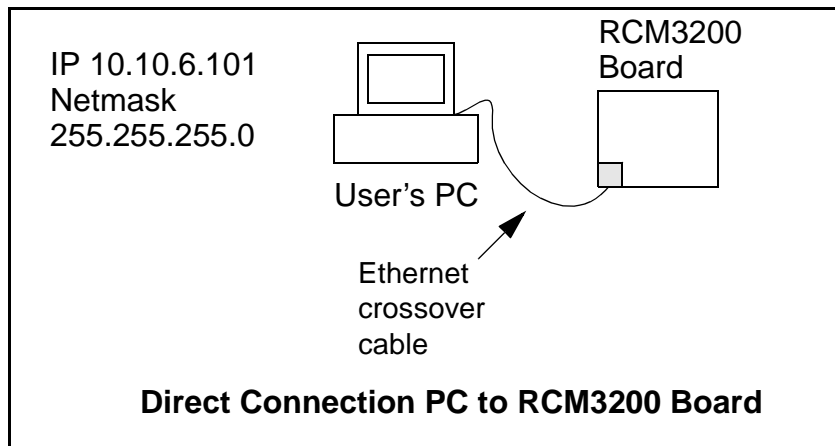

6.4.3 Dynamic C Compiler Settings

If you are using an RCM3200 or RCM3220, remember to allow the compiler to run the application in the program execution SRAM by selecting **Code and BIOS in Flash, Run in RAM** from the **Dynamic C Options > Project Options > Compiler** menu.

6.5 Run the `PINGME.C` Sample Program

Connect the crossover cable from your computer's Ethernet port to the RCM3200 board's RJ-45 Ethernet connector. Open this sample program from the `SAMPLES\TCPIP\ICMP` folder, compile the program, and start it running under Dynamic C. When the program starts running, the green **LNK** light on the RCM3200 board should be on to indicate an Ethernet connection is made. (Note: If the **LNK** light does not light, you may not have a crossover cable, or if you are using a hub perhaps the power is off on the hub.)

The next step is to ping the board from your PC. This can be done by bringing up the MS-DOS window and running the pingme program:

```
ping 10.10.6.100
```

or by **Start > Run**

and typing the entry

```
ping 10.10.6.100
```

Notice that the red **ACT** light flashes on the RCM3200 board while the ping is taking place, and indicates the transfer of data. The ping routine will ping the board four times and write a summary message on the screen describing the operation.

6.6 Running More Sample Programs With Direct Connect

The sample programs discussed here are in the Dynamic C `SAMPLES\RCM3200\TCPIP` folder.

- **BROWSELED.C**—This program demonstrates a basic controller running a Web page. Two “LEDs” are created on the Web page, and two buttons on the Prototyping Board then toggle them. Users can change the status of the lights from the Web browser. The LEDs on the Prototyping Board match the ones on the Web page. As long as you have not modified the `TCPCONFIG 1` macro in the sample program, enter the following server address in your Web browser to bring up the Web page served by the sample program.

```
http://10.10.6.100.
```

Otherwise use the TCP/IP settings you entered in the `TCP_CONFIG.LIB` library.

- **ECHOCLIENT.C**—This program demonstrates a basic client that will send a packet and wait for the connected server to echo it back. After every number of sends and receives, transfer times are shown in the **STDIO** window.

Use **ECHO_SERVER.C** to program a server controller.

- **ECHOSERVER.C**—This program demonstrates a basic server that will echo back any data sent from a connected client.

Use **ECHO_CLIENT.C** to program a client controller.

- **ENET_AD.C**—This program demonstrates Ethernet communication between two single-board computers. The program sends an A/D voltage value to the second single-board computer via Ethernet for display.

Use **ENET_MENU.C** to program the other single-board computer.

- **ENET_MENU.C**—This program demonstrates how to implement a menu system using a highlight bar on a graphic LCD display and to communicate it to another single-board computer via Ethernet.

Use **ENET_AD.C** to program the other single-board computer with analog inputs and outputs.

- **MBOXDEMO.C**—Implements a Web server that allows e-mail messages to be entered and then shown on the LCD/keypad module.
- **SMTP.C**—This program allows you to send an E-mail when a switch on the Prototyping Board is pressed. Follow the instructions included with the sample program.
- **PINGLED.C**—This program demonstrates ICMP by pinging a remote host. It will flash LEDs DS1 and DS2 on the Prototyping Board when a ping is sent and received.

6.7 Where Do I Go From Here?

NOTE: If you purchased your RCM3200 through a distributor or through a Rabbit partner, contact the distributor or partner first for technical support.

If there are any problems at this point:

- Use the Dynamic C **Help** menu to get further assistance with Dynamic C.
- Check the Rabbit Technical Bulletin Board and forums at www.rabbit.com/support/bb/ and at www.rabbit.com/forums/.
- Use the Technical Support e-mail form at www.rabbit.com/support/.

If the sample programs ran fine, you are now ready to go on.

Additional sample programs are described in the *Dynamic C TCP/IP User's Manual*.

Please refer to the *Dynamic C TCP/IP User's Manual* to develop your own applications. *An Introduction to TCP/IP* provides background information on TCP/IP, and is available on the CD and on our [Web site](#).



APPENDIX A. RCM3200 SPECIFICATIONS

Appendix A provides the specifications for the RCM3200, and describes the conformal coating.

A.1 Electrical and Mechanical Characteristics

Figure A-1 shows the mechanical dimensions for the RCM3200.

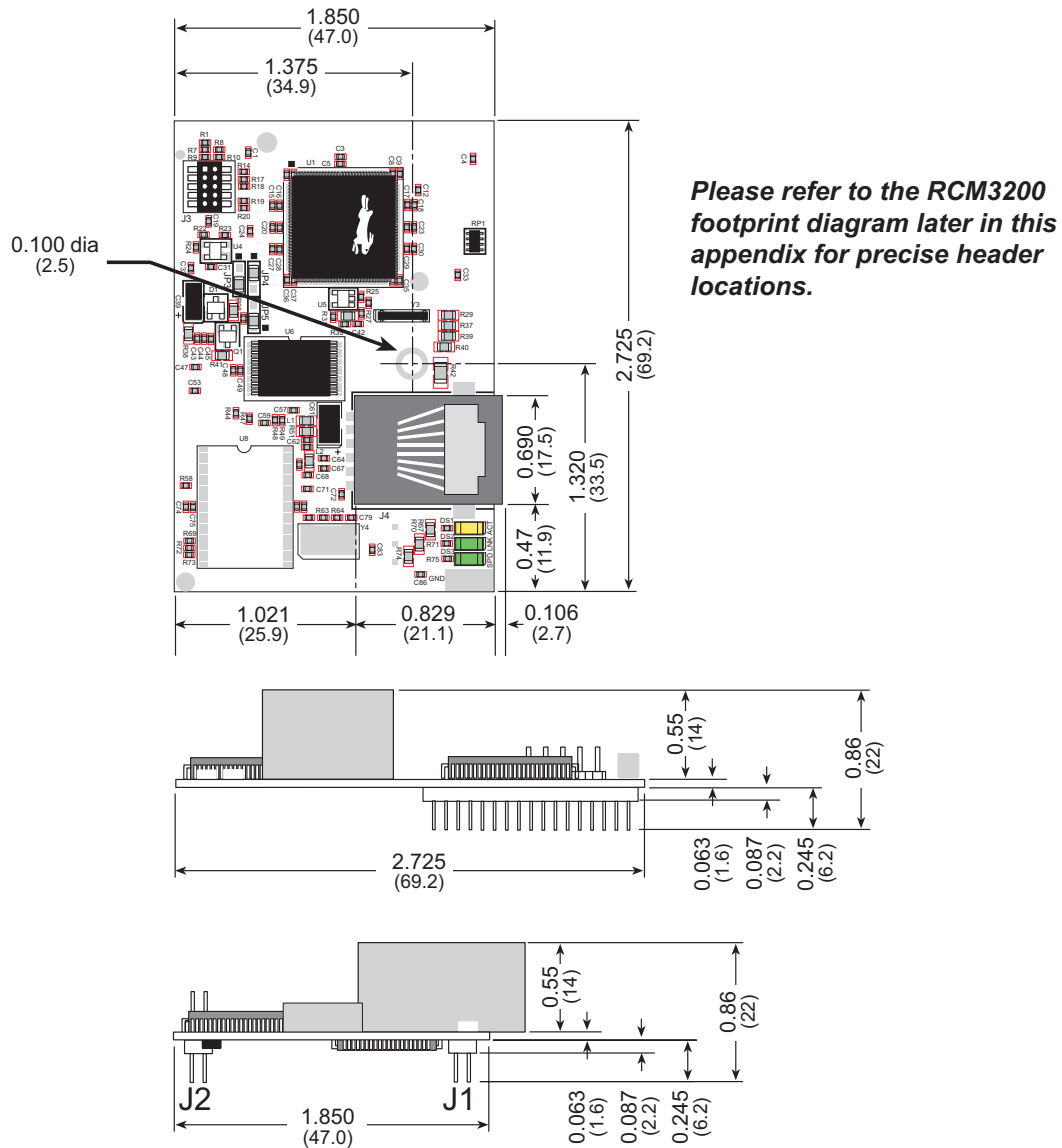

Figure A-1. RCM3200 Dimensions

NOTE: All measurements are in inches followed by millimeters enclosed in parentheses.
All dimensions have a manufacturing tolerance of ± 0.01 " (0.25 mm).

It is recommended that you allow for an “exclusion zone” of 0.04" (1 mm) around the RCM3200 in all directions (except above the RJ-45 plug) when the RCM3200 is incorporated into an assembly that includes other printed circuit boards. This “exclusion zone” that you keep free of other components and boards will allow for sufficient air flow, and will help to minimize any electrical or electromagnetic interference between adjacent boards. An “exclusion zone” of 0.08" (2 mm) is recommended below the RCM3200 when the RCM3200 is plugged into another assembly using the shortest connectors for headers J1 and J2. Figure A-2 shows this “exclusion zone.”

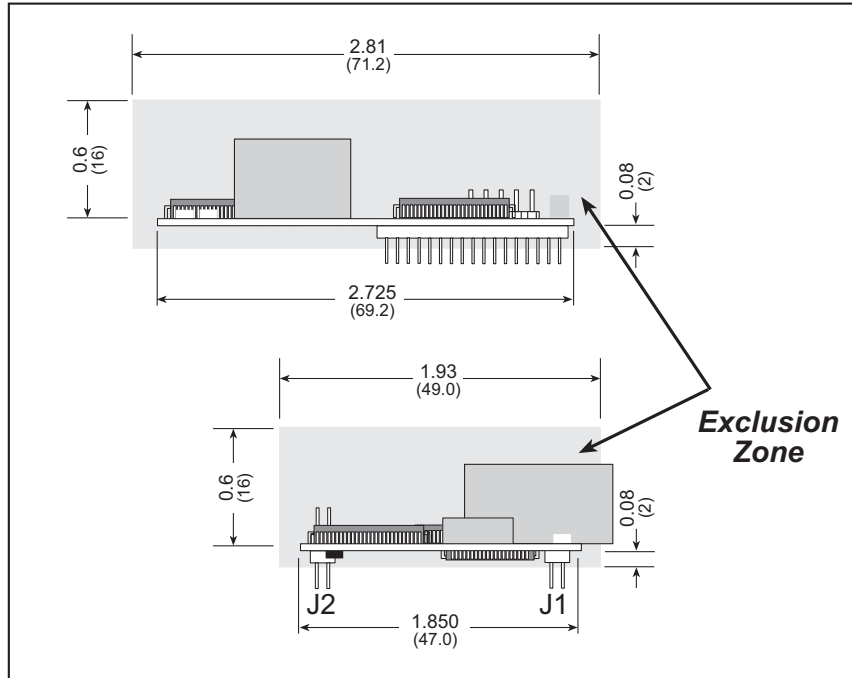

Figure A-2. RCM3200 “Exclusion Zone”

Table A-1 lists the electrical, mechanical, and environmental specifications for the RCM3200.

Table A-1. RabbitCore RCM3200 Specifications

Feature	RCM3200	RCM3210*	RCM3220
Microprocessor	Rabbit 3000® at 44.2 MHz	Rabbit 3000® at 29.5 MHz	Rabbit 3000® at 44.2 MHz
EMI Reduction	Spectrum spreader for reduced EMI (radiated emissions)		
Ethernet Port	10/100Base-T, RJ-45, 3 LEDs		—
Flash Memory	512K	256K	512K
Data SRAM	256K	128K	256K
Program Execution SRAM	512K	—	512K
Backup Battery	Connection for user-supplied backup battery (to support RTC and data SRAM)		
General-Purpose I/O	52 parallel digital I/O lines: <ul style="list-style-type: none"> • 44 configurable I/O • 4 fixed inputs • 4 fixed outputs 		
Additional Inputs	Startup mode (2), reset in		
Additional Outputs	Status, reset out		
External I/O Bus	Can be configured for 8 data lines and 6 address lines (shared with parallel I/O lines), plus I/O read/write		
Serial Ports	6 shared high-speed, CMOS-compatible ports: <ul style="list-style-type: none"> • all 6 configurable as asynchronous (with IrDA), 4 as clocked serial (SPI), and 2 as SDLC/HDLC (with IrDA) • 1 asynchronous serial port dedicated for programming • support for MIR/SIR IrDA transceiver 		
Serial Rate	Maximum asynchronous baud rate = CLK/8		
Slave Interface	A slave port allows the RCM3200 to be used as an intelligent peripheral device slaved to a master processor, which may either be another Rabbit 3000 or any other type of processor		
Real-Time Clock	Yes		
Timers	Ten 8-bit timers (6 cascadable), one 10-bit timer with 2 match registers		
Watchdog/Supervisor	Yes		
Pulse-Width Modulators	10-bit free-running counter and four pulse-width registers		
Input Capture	2- channel input capture can be used to time input signals from various port pins		
Quadrature Decoder	2-channel quadrature decoder accepts inputs from external incremental encoder modules		

Table A-1. RabbitCore RCM3200 Specifications (continued)

Feature	RCM3200	RCM3210*	RCM3220
Power	3.15 V to 3.45 V DC 255 mA @ 3.3 V		
Operating Temperature	-40°C to +70°C (boards manufactured up to May, 2008) 0°C to +70°C (boards manufactured after May, 2008)		
Humidity	5% to 95%, noncondensing		
Connectors	Two 2 × 17, 2 mm pitch		
Board Size	1.850" × 2.725" × 0.86" (47 mm × 69 mm × 22 mm)		

* The RCM3210 was discontinued in July, 2004, and is no longer offered.

A.1.1 Headers

The RCM3200 uses headers at J1 and J2 for physical connection to other boards. J1 and J2 are 2 × 17 SMT headers with a 2 mm pin spacing. J3, the programming port, is a 2 × 5 header with a 1.27 mm pin spacing.

Figure A-3 shows the layout of another board for the RCM3200 to be plugged into. These values are relative to the mounting hole.

A.1.2 Physical Mounting

A 9/32" (7 mm) standoff with a 2-56 screw is recommended to attach the RCM3200 to a user board at the hole position shown in Figure A-3. Either use plastic hardware, or use insulating washers to keep any metal hardware from shorting out signals on the RCM3200.

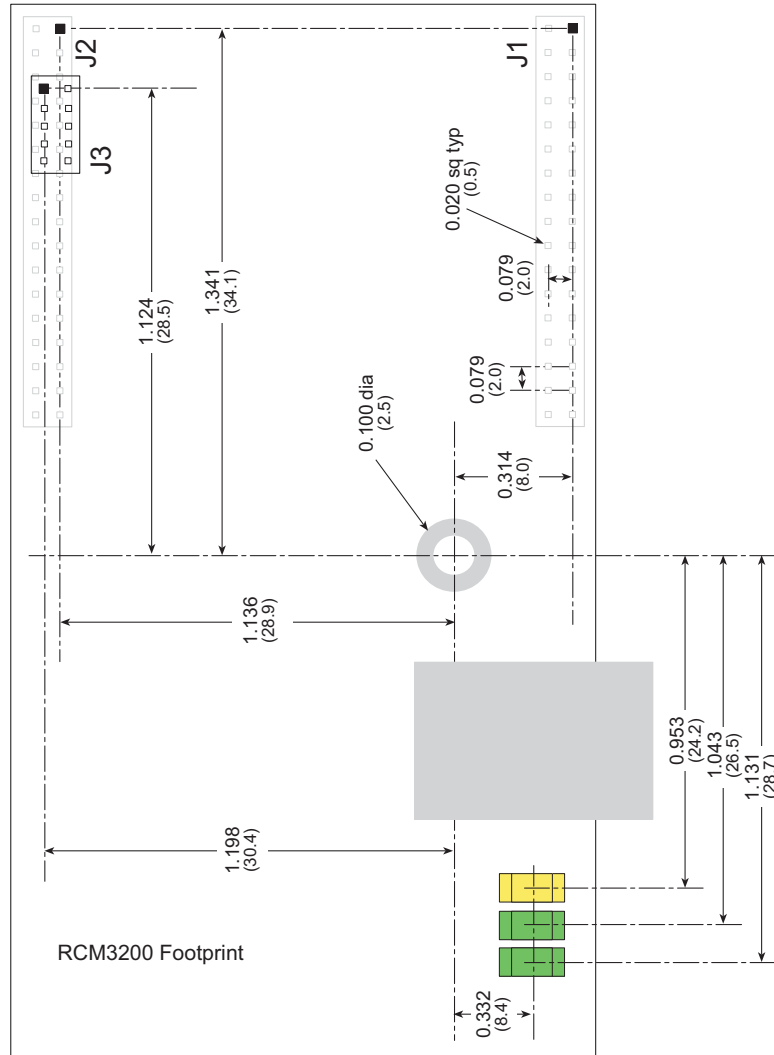

Figure A-3. User Board Footprint for RCM3200

A.2 Bus Loading

You must pay careful attention to bus loading when designing an interface to the RCM3200. This section provides bus loading information for external devices.

Table A-2 lists the capacitance for the various RCM3200 I/O ports.

Table A-2. Capacitance of Rabbit 3000 I/O Ports

I/O Ports	Input Capacitance (pF)	Output Capacitance (pF)
Parallel Ports A to G	12	14

Table A-3 lists the external capacitive bus loading for the various RCM3200 output ports. Be sure to add the loads for the devices you are using in your custom system and verify that they do not exceed the values in Table A-3.

Table A-3. External Capacitive Bus Loading -40°C to +70°C

Output Port	Clock Speed (MHz)	Maximum External Capacitive Loading (pF)
All I/O lines with clock doubler enabled	44.2	100

Figure A-4 shows a typical timing diagram for the Rabbit 3000 microprocessor external I/O read and write cycles.

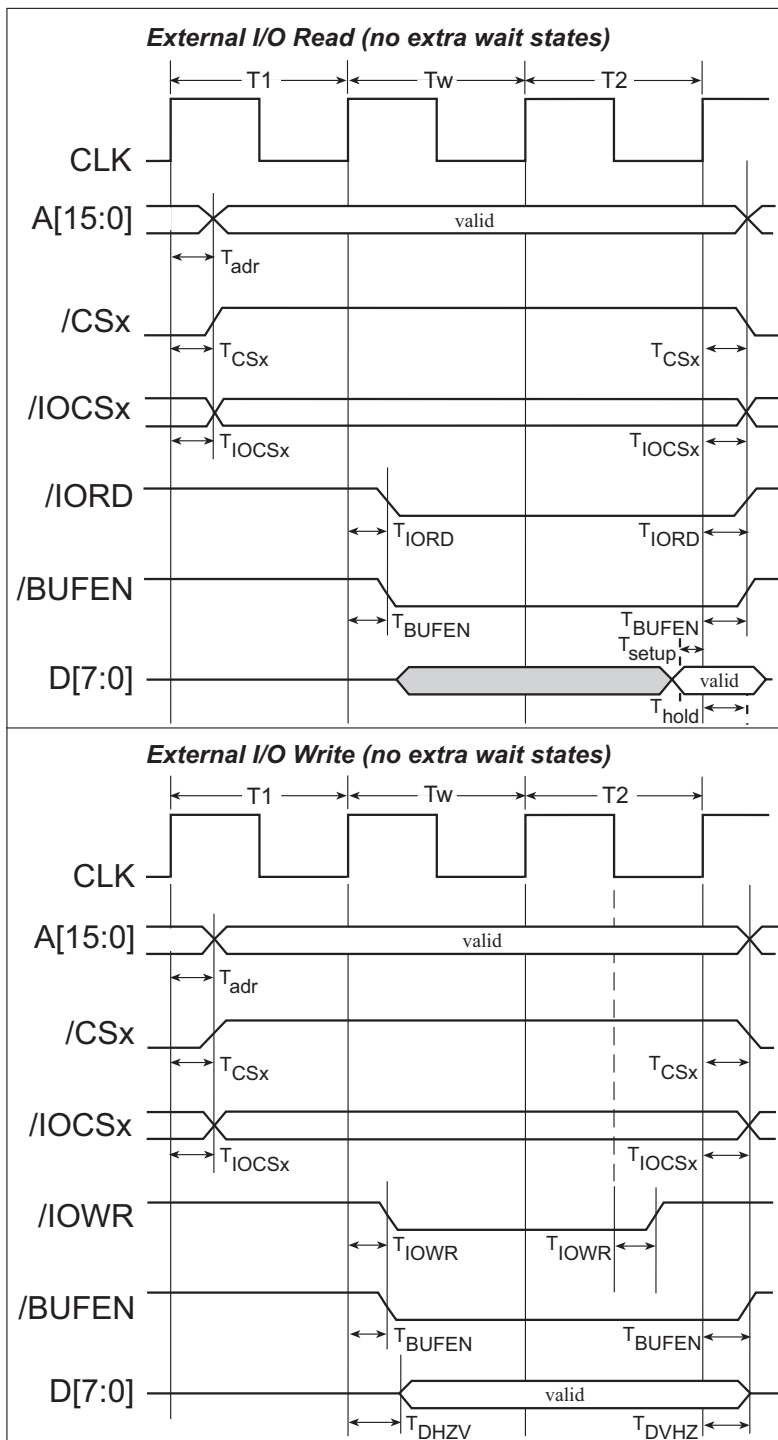

Figure A-4. I/O Read and Write Cycles—No Extra Wait States

NOTE: /IOCSx can be programmed to be active low (default) or active high.

Table A-4 lists the delays in gross memory access time for $V_{DD} = 3.3$ V.

Table A-4. Data and Clock Delays $V_{DD} \pm 10\%$, Temp, -40°C – $+85^{\circ}\text{C}$ (maximum)

VDD	Clock to Address Output Delay (ns)			Data Setup Time Delay (ns)	Spectrum Spreader Delay (ns)	
	30 pF	60 pF	90 pF		Normal dbl/no dbl	Strong dbl/no dbl
3.3	6	8	11	1	3/4.5	4.5/9

The measurements are taken at the 50% points under the following conditions.

- $T = -40^{\circ}\text{C}$ to 85°C , $V = V_{DD} \pm 10\%$
- Internal clock to nonloaded CLK pin delay ≤ 1 ns @ $85^{\circ}\text{C}/3.0$ V

The clock to address output delays are similar, and apply to the following delays.

- T_{adr} , the clock to address delay
- T_{CS_x} , the clock to memory chip select delay
- T_{IOCS_x} , the clock to I/O chip select delay
- T_{IORD} , the clock to I/O read strobe delay
- T_{IOWR} , the clock to I/O write strobe delay
- T_{BUFEN} , the clock to I/O buffer enable delay

The data setup time delays are similar for both T_{setup} and T_{hold} .

When the spectrum spreader is enabled with the clock doubler, every other clock cycle is shortened (sometimes lengthened) by a maximum amount given in the table above. The shortening takes place by shortening the high part of the clock. If the doubler is not enabled, then every clock is shortened during the low part of the clock period. The maximum shortening for a pair of clocks combined is shown in the table.

Technical Note TN227, *Interfacing External I/O with Rabbit 2000/3000 Designs*, contains suggestions for interfacing I/O devices to the Rabbit 3000 microprocessors.

A.3 Rabbit 3000 DC Characteristics

Table A-5 outlines the DC characteristics for the Rabbit at 3.3 V over the recommended operating temperature range from $T_a = -55^{\circ}\text{C}$ to $+125^{\circ}\text{C}$, $V_{DD} = 3.0\text{ V}$ to 3.6 V .

Table A-5. 3.3 Volt DC Characteristics

Symbol	Parameter	Test Conditions	Min	Typ	Max	Units
I_{IH}	Input Leakage High	$V_{IN} = V_{DD}$, $V_{DD} = 3.3\text{ V}$			1	μA
I_{IL}	Input Leakage Low (no pull-up)	$V_{IN} = V_{SS}$, $V_{DD} = 3.3\text{ V}$	-1			μA
I_{OZ}	Output Leakage (no pull-up)	$V_{IN} = V_{DD}$ or V_{SS} , $V_{DD} = 3.3\text{ V}$	-1		1	μA
V_{IL}	CMOS Input Low Voltage				$0.3 \times V_{DD}$	V
V_{IH}	CMOS Input High Voltage		$0.7 \times V_{DD}$			V
V_T	CMOS Switching Threshold	$V_{DD} = 3.3\text{ V}$, 25°C		1.65		V
V_{OL}	Low-Level Output Voltage	$I_{OL} = \text{See (sinking)}$ $V_{DD} = 3.0\text{ V}$			0.4	V
V_{OH}	High-Level Output Voltage	$I_{OH} = \text{See (sourcing)}$ $V_{DD} = 3.0\text{ V}$	$0.7 \times V_{DD}$			V

A.4 I/O Buffer Sourcing and Sinking Limit

Unless otherwise specified, the Rabbit I/O buffers are capable of sourcing and sinking 6.8 mA of current per pin at full AC switching speed. Full AC switching assumes a 29.4 MHz CPU clock and capacitive loading on address and data lines of less than 70 pF per pin. The absolute maximum operating voltage on all I/O is 5.5 V.

Table A-6 shows the AC and DC output drive limits of the parallel I/O buffers when the Rabbit 3000 is used in the RCM3200.

Table A-6. I/O Buffer Sourcing and Sinking Capability

Pin Name	Output Drive (Full AC Switching) Sourcing/Sinking Limits (mA)	
	Sourcing	Sinking
All data, address, and I/O lines with clock doubler enabled	6.8	6.8

Under certain conditions, you can exceed the limits outlined in Table A-6. See the *Rabbit 3000 Microprocessor User's Manual* for additional information.

A.5 Conformal Coating

The areas around the 32 kHz real-time clock crystal oscillator has had the Dow Corning silicone-based 1-2620 conformal coating applied. The conformally coated area is shown in Figure A-5. The conformal coating protects these high-impedance circuits from the effects of moisture and contaminants over time.

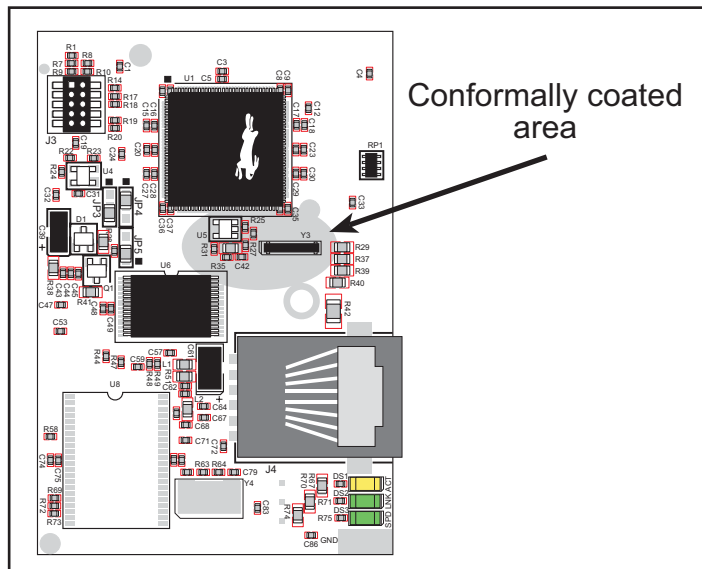

Figure A-5. RCM3200 Areas Receiving Conformal Coating

Any components in the conformally coated area may be replaced using standard soldering procedures for surface-mounted components. A new conformal coating should then be applied to offer continuing protection against the effects of moisture and contaminants.

NOTE: For more information on conformal coatings, refer to Technical Note 303, *Conformal Coatings*.

A.6 Jumper Configurations

Figure A-6 shows the header locations used to configure the various RCM3200 options via jumpers.

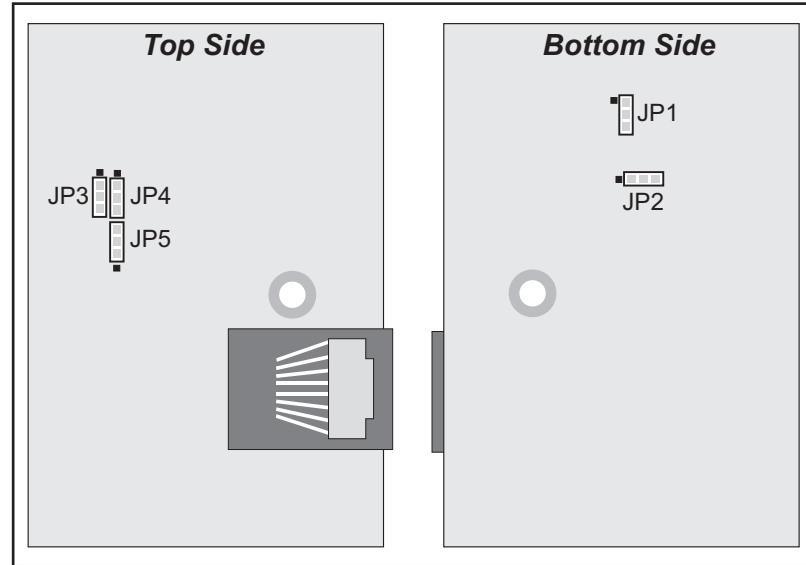

Figure A-6. Location of RCM3200 Configurable Positions

Table A-7 lists the configuration options.

Table A-7. RCM3200 Jumper Configurations

Header	Description	Pins Connected		Factory Default
JP1	External I/O data bus	1-2	Buffer disabled	
		2-3	Buffer enabled	×
JP2	Program Execution SRAM Size	1-2	128K/256K	
		2-3	512K	×
JP3	Flash Memory Size	1-2	128K/256K	
		2-3	512K	×
JP4	Flash Memory Bank Select	1-2	Normal Mode	×
		2-3	Bank Mode	
JP5	Data SRAM Size	1-2	256K	×
		2-3	512K	

NOTE: The jumper connections are made using 0 Ω surface-mounted resistors.



APPENDIX B. PROTOTYPING BOARD

Appendix B describes the features and accessories of the Prototyping Board, and explains the use of the Prototyping Board to demonstrate the RCM3200 and to build prototypes of your own circuits.

B.1 Introduction

The Prototyping Board included in the Development Kit makes it easy to connect an RCM3200 module to a power supply and a PC workstation for development. It also provides some basic I/O peripherals (switches and LEDs), as well as a prototyping area for more advanced hardware development.

For the most basic level of evaluation and development, the Prototyping Board can be used without modification.

As you progress to more sophisticated experimentation and hardware development, modifications and additions can be made to the board without modifying or damaging the RCM3200 module itself.

The Prototyping Board is shown below in Figure B-1, with its main features identified.

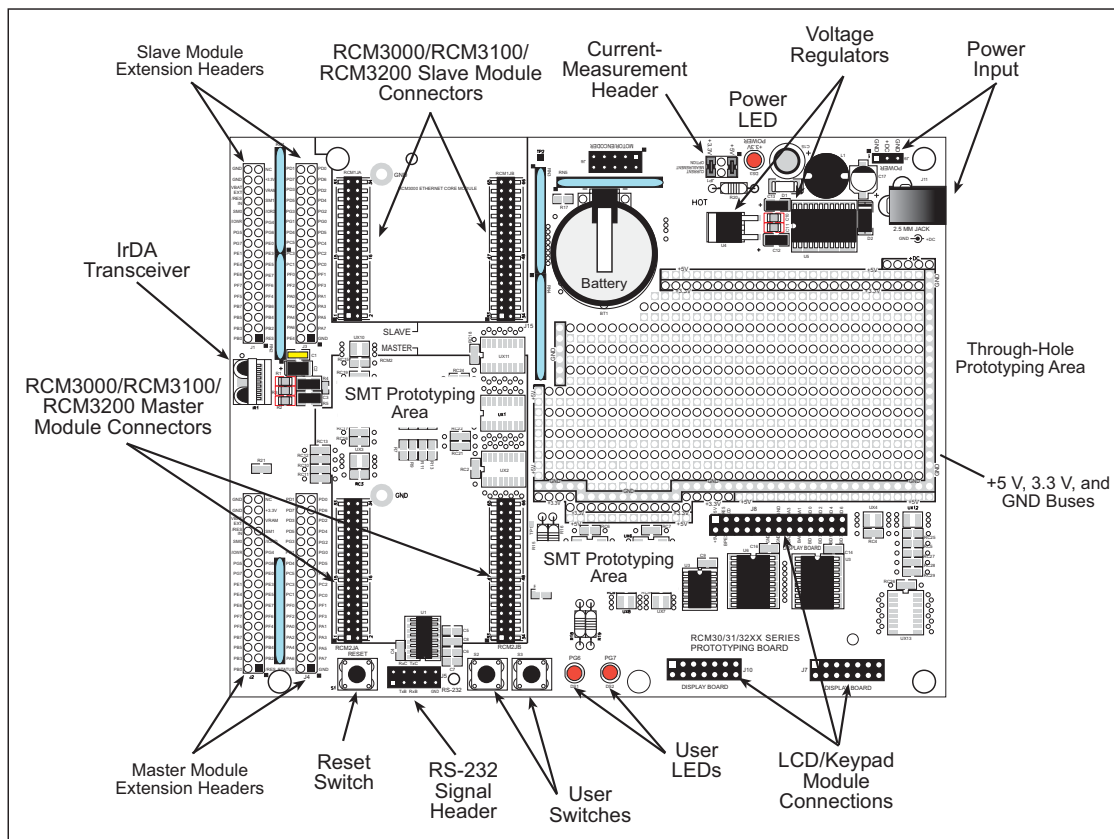

Figure B-1. Prototyping Board

B.1.1 Prototyping Board Features

- **Power Connection**—A power-supply jack and a 3-pin header are provided for connection to the power supply. Note that the 3-pin header is symmetrical, with both outer pins connected to ground and the center pin connected to the raw V+ input. The cable of the AC adapter provided with the North American version of the Development Kit ends in a plug that connects to the power-supply jack. The header plug leading to bare leads provided for overseas customers can be connected to the 3-pin header in either orientation.

Users providing their own power supply should ensure that it delivers 8–24 V DC at 8 W. The voltage regulators will get warm while in use.

- **Regulated Power Supply**—The raw DC voltage provided at the POWER IN jack is routed to a 5 V switching voltage regulator, then to a separate 3.3 V linear regulator. The regulators provide stable power to the RCM3200 module and the Prototyping Board.
- **Power LED**—The power LED lights whenever power is connected to the Prototyping Board.
- **Reset Switch**—A momentary-contact, normally open switch is connected directly to the RCM3200's /RESET_IN pin. Pressing the switch forces a hardware reset of the system.
- **I/O Switches and LEDs**—Two momentary-contact, normally open switches are connected to the PG0 and PG1 pins of the master RCM3200 module and may be read as inputs by sample applications.

Two LEDs are connected to the PG6 and PG7 pins of the master module, and may be driven as output indicators by sample applications.

- **Prototyping Area**—A generous prototyping area has been provided for the installation of through-hole components. +3.3 V, +5 V, and Ground buses run around the edge of this area. Several areas for surface-mount devices are also available. (Note that there are SMT device pads on both top and bottom of the Prototyping Board.) Each SMT pad is connected to a hole designed to accept a 30 AWG solid wire.
- **Master Module Connectors**—A set of connectors is pre-wired to permit installation of the first RCM3000, RCM3100, or RCM3200 module that serves as the primary or “master module.”
- **Slave Module Connectors**—A second set of connectors is pre-wired to permit installation of a second, slave RCM3200, RCM3100, or RCM3000 module. This capability is reserved for future use, although the schematics in this manual contain all of the details an experienced developer will need to implement a master-slave system.
- **Module Extension Headers**—The complete pin sets of both the **MASTER** and **SLAVE** RabbitCore modules are duplicated at these two sets of headers. Developers can solder wires directly into the appropriate holes, or, for more flexible development, 26-pin header strips can be soldered into place. See Figure B-4 for the header pinouts.

- **RS-232**—Two 3-wire or one 5-wire RS-232 serial port are available on the Prototyping Board. Refer to the Prototyping Board schematic (090-0137) for additional details.

A 10-pin 0.1-inch spacing header strip is installed at J5 to permit connection of a ribbon cable leading to a standard DE-9 serial connector.

- **Current Measurement Option**—Jumpers across pins 1–2 and 5–6 on header JP1 can be removed and replaced with an ammeter across the pins to measure the current drawn from the +5 V or the +3.3 V supplies, respectively.
- **Motor Encoder**—A motor/encoder header is provided at header J6 for future use.
- **LCD/Keypad Module**—Rabbit's LCD/keypad module may be plugged in directly to headers J7, J8, and J10.

B.2 Mechanical Dimensions and Layout

Figure B-2 shows the mechanical dimensions and layout for the Prototyping Board.

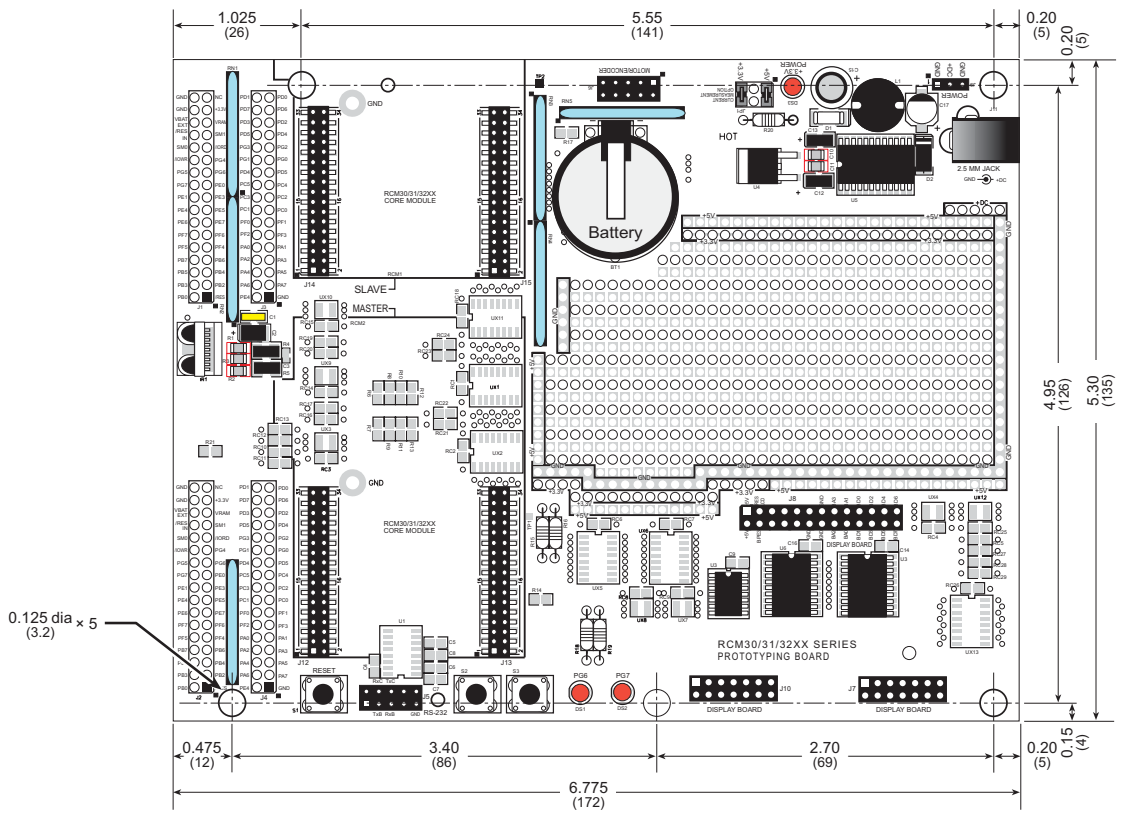

Figure B-2. RCM30/31/32XX Prototyping Board Dimensions

NOTE: All measurements are in inches followed by millimeters enclosed in parentheses. All dimensions have a manufacturing tolerance of ± 0.01 " (0.25 mm).

Table B-1 lists the electrical, mechanical, and environmental specifications for the Prototyping Board.

Table B-1. Prototyping Board Specifications

Parameter	Specification
Board Size	5.30" × 6.775" × 1.00" (135 mm × 172 mm × 25 mm)
Operating Temperature	-20°C to +60°C
Humidity	5% to 95%, noncondensing
Input Voltage	8 V to 24 V DC
Maximum Current Draw (including user-added circuits)	800 mA max. for +3.3 V supply, 1 A total +3.3 V and +5 V combined
Prototyping Area	2.0" × 3.5" (50 mm × 90 mm) throughhole, 0.1" spacing, additional space for SMT components
Standoffs/Spacers	5, accept 4-40 × 3/8 screws

B.3 Power Supply

The RCM3200 requires a regulated 3.3 V ± 0.15 V DC power source to operate. Depending on the amount of current required by the application, different regulators can be used to supply this voltage.

The Prototyping Board has an onboard +5 V switching power regulator from which a +3.3 V linear regulator draws its supply. Thus both +5 V and +3.3 V are available on the Prototyping Board.

The Prototyping Board itself is protected against reverse polarity by a Shottky diode at D2 as shown in Figure B-3.

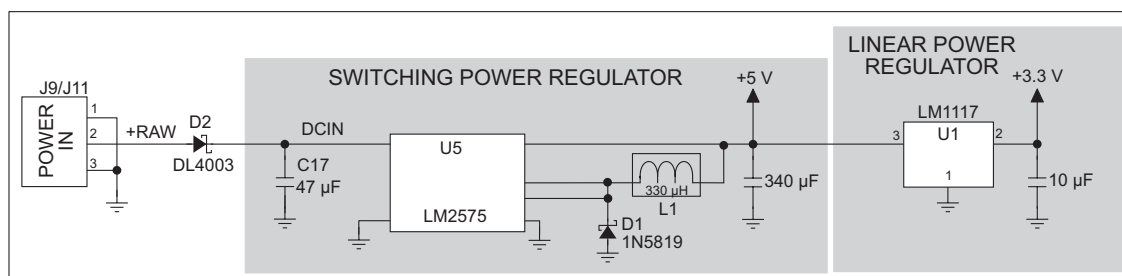

Figure B-3. Prototyping Board Power Supply

B.4 Using the Prototyping Board

The Prototyping Board is actually both a demonstration board and a prototyping board. As a demonstration board, it can be used to demonstrate the functionality of the RCM3200 right out of the box without any modifications to either board. There are no jumpers or dip switches to configure or misconfigure on the Prototyping Board so that the initial setup is very straightforward.

The Prototyping Board comes with the basic components necessary to demonstrate the operation of the RCM3200. Two LEDs (DS1 and DS2) are connected to PG6 and PG7, and two switches (S2 and S3) are connected to PG1 and PG0 to demonstrate the interface to the Rabbit 3000 microprocessor. Reset switch S1 is the hardware reset for the RCM3200.

The Prototyping Board provides the user with RCM3200 connection points brought out conveniently to labeled points at headers J2 and J4 on the Prototyping Board. Small to medium circuits can be prototyped using point-to-point wiring with 20 to 30 AWG wire between the prototyping area and the holes at locations J2 and J4. The holes are spaced at 0.1" (2.5 mm), and 40-pin headers or sockets may be installed at J2 and J4. The pinouts for locations J2 and J4, which correspond to headers J1 and J2, are shown in Figure B-4.

J2			J4		
GND	□ □	n.c.	PD1	□ □	PD0
GND	□ □	+3.3V	PD7	□ □	PD6
VBAT_EXT	□ □	VRAM	PD3	□ □	PD2
/RESET_IN	□ □	SMODE1	PD5	□ □	PD4
SMODE0	□ □	/IORD	PG3	□ □	PG2
/IOWR	□ □	PG4	PG1	□ □	PG0
PG5	□ □	PG6	PC7	□ □	PC6
PG7	□ □	PE0	PC5	□ □	PC4
PE1	□ □	PE3	PC3	□ □	PC2
PE4	□ □	PE5	PC1	□ □	PC0
PE6	□ □	PE7	PF0	□ □	PF1
PF7	□ □	PF6	PF2	□ □	PF3
PF5	□ □	PF4	PA0	□ □	PA1
PB7	□ □	PB6	PA2	□ □	PA3
PB5	□ □	PB4	PA4	□ □	PA5
PB3	□ □	PB2	PA6	□ □	PA7
PB0	□ ■	/RES	STATUS	□ ■	GND

n.c. = not connected

**Figure B-4. Prototyping Board Pinout
(Top View)**

The small holes are also provided for surface-mounted components that may be installed around the prototyping area.

There is a 2.0" × 3.5" through-hole prototyping space available on the Prototyping Board. +3.3 V, +5 V, and GND traces run along the edge of the Prototyping Board for easy access.

B.4.1 Adding Other Components

There are pads that can be used for surface-mount prototyping involving SOIC devices. There is provision for seven 16-pin devices (six on one side, one on the other side). There are 10 sets of pads that can be used for 3- to 6-pin SOT23 packages. There are also pads that can be used for SMT resistors and capacitors in an 0805 SMT package. Each component has every one of its pin pads connected to a hole in which a 30 AWG wire can be soldered (standard wire wrap wire can be soldered in for point-to-point wiring on the Prototyping Board). Because the traces are very thin, carefully determine which set of holes is connected to which surface-mount pad.

B.4.2 Measuring Current Draw

The Prototyping Board has a current-measurement feature available on header JP1. Normally, a jumper connects pins 1–2 and pins 5–6 on header JP1, which provide jumper connections for the +5 V and the +3.3 V regulated voltages respectively. You may remove a jumper and place an ammeter across the pins instead, as shown in the example in Figure B-5, to measure the current being drawn.

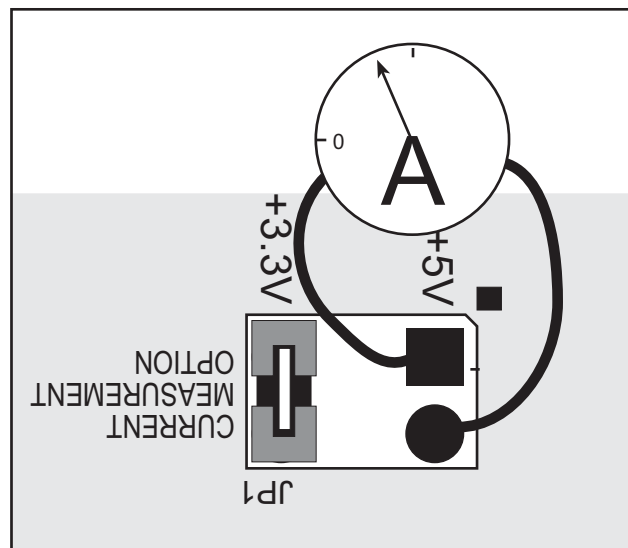

Figure B-5. Prototyping Board Current-Measurement Option

B.4.3 Other Prototyping Board Modules and Options

With the RCM3200 plugged into the **MASTER** slots, it has full access to the RS-232 transceiver, and can act as the “master” relative to another RabbitCore RCM3000, RCM3100, or RCM3200 plugged into the **SLAVE** slots, which acts as the “slave.”

An optional LCD/keypad module is available that can be mounted on the Prototyping Board. Refer to Appendix C, “LCD/Keypad Module,” for complete information.

The RCM3200 has a 2-channel quadrature decoder and a 10-bit free-running PWM counter with four pulse-width registers. These features allow the RCM3200 to be used in a motor control application, although Rabbit does not offer the drivers or a compatible stepper motor control board at this time.

The Prototyping Board has a header at J6 to which a customer-developed motor encoder may be connected. Figure B-6 shows the motor encoder pinout at header J6.

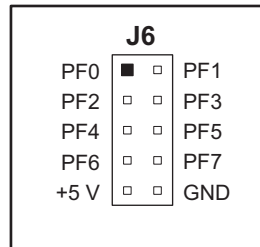

Figure B-6. Prototyping Board Motor Encoder Connector Pinout

Refer to Appendix E, “Motor Control Option,” for complete information on using the Rabbit 3000’s Parallel Port F in conjunction with this application.

B.5 Use of Rabbit 3000 Parallel Ports

Table B-2 lists the Rabbit 3000 parallel ports and their use for the RCM30/31/32XX Prototyping Board.

**Table B-2. RCM30/31/32XX Prototyping Board
Use of Rabbit 3000 Parallel Ports**

Port	I/O	Use	Initial State
PA0–PA7	Output	Configurable external I/O bus	High when not driven by I/O bus
PB0–PB1	Input	Not used	Pulled up on RCM3200
PB2–PB5	Input	Configurable external I/O bus	High when not driven by I/O bus
PB6–PB7	Output	Not used	Pulled up on RCM3200
PC0	Output	Not used	High (disabled)
PC1	Input	Not used	Pulled up on RCM3200
PC2	Output	TXC	High (disabled)
PC3	Input	RXC	Pulled up on RCM3200
PC4	Output	TXB	High (disabled)
PC5	Input	RXB	Pulled up on RCM3200
PC6	Output	TXA Programming Port	High (disabled)
PC7	Input	RXA Programming Port	Pulled up on RCM3200
PD0	Output	Ethernet RSTDRV	High
PD1	Input	Not used	Pulled up on RCM3200
PD2–PD4	Output	Not used	High
PD5	Input	Not used	Pulled up on Prototyping Board
PD6–PD7	Output	Not used	High
PE0–PE1	Output	Not used	High
PE2	Output	Ethernet chip select	High
PE3	Output	LCD device select	Low (disabled)
PE4	Output	IrDA speed select	Low (disabled)
PE5	Output	Not used	High
PE6	Output	External I/O strobe	High (disabled)
PE7	Output	Not used	High (disabled)

**Table B-2. RCM30/31/32XX Prototyping Board
Use of Rabbit 3000 Parallel Ports (continued)**

Port	I/O	Use		Initial State
PF0–PF7	Input	Reserved for future use		Pulled up on Prototyping Board
PG0	Input	Switch S3 (normally open)		High
PG1	Input	Switch S2 (normally open)		High
PG2	Output	TXF IrDA	Serial Port F	Pulled down
PG3	Input	RXF IrDA		Driven by IrDA driver
PG4	Input	IrDA MD1		Pulled up on Prototyping Board
PG5	Input	IrDA MD0		Pulled down on Prototyping Board
PG6	Output	LED DS1		High (disabled)
PG7	Output	LED DS2		High (disabled)

APPENDIX C. LCD/KEYPAD MODULE

An optional LCD/keypad is available for the Prototyping Board. Appendix C describes the LCD/keypad and provides the software function calls to make full use of the LCD/keypad.

C.1 Specifications

Two optional LCD/keypad modules—with or without a panel-mounted bezel—are available for use with the Prototyping Board. They are shown in Figure C-1.

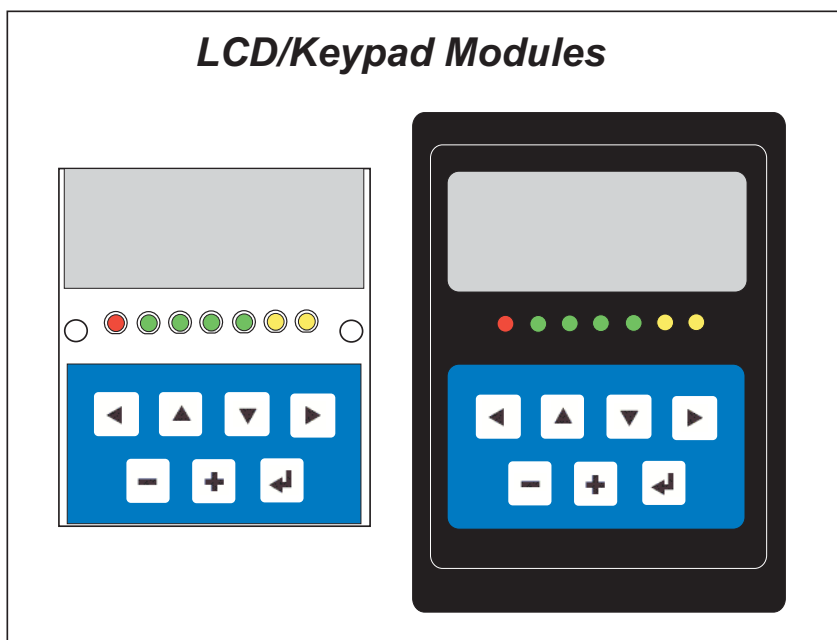

Figure C-1. LCD/Keypad Modules Models

Only the version without the bezel can mount directly on the Prototyping Board; if you have the version with a bezel, you will have to remove the bezel to be able to mount the LCD/keypad module on the Prototyping Board. Either version of the LCD/keypad module can be installed at a remote location up to 60 cm (24") away. Contact your Rabbit sales representative or your authorized distributor for further assistance in purchasing an LCD/keypad module.

Mounting hardware and a 60 cm (24") extension cable are also available for the LCD/keypad module through your sales representative or authorized distributor.

Table C-1 lists the electrical, mechanical, and environmental specifications for the LCD/keypad module.

Table C-1. LCD/Keypad Specifications

Parameter	Specification
Board Size	2.60" × 3.00" × 0.75" (66 mm × 76 mm × 19 mm)
Bezel Size	4.50" × 3.60" × 0.30" (114 mm × 91 mm × 7.6 mm)
Temperature	Operating Range: 0°C to +50°C Storage Range: -40°C to +85°C
Humidity	5% to 95%, noncondensing
Power Consumption	1.5 W maximum*
Connections	Connects to high-rise header sockets on the Prototyping Board
LCD Panel Size	122 × 32 graphic display
Keypad	7-key keypad
LEDs	Seven user-programmable LEDs

* The backlight adds approximately 650 mW to the power consumption.

The LCD/keypad module has 0.1" IDC headers at J1, J2, and J3 for physical connection to other boards or ribbon cables. Figure C-2 shows the LCD/keypad module footprint. These values are relative to one of the mounting holes.

NOTE: All measurements are in inches followed by millimeters enclosed in parentheses. All dimensions have a manufacturing tolerance of ±0.01" (0.25 mm).

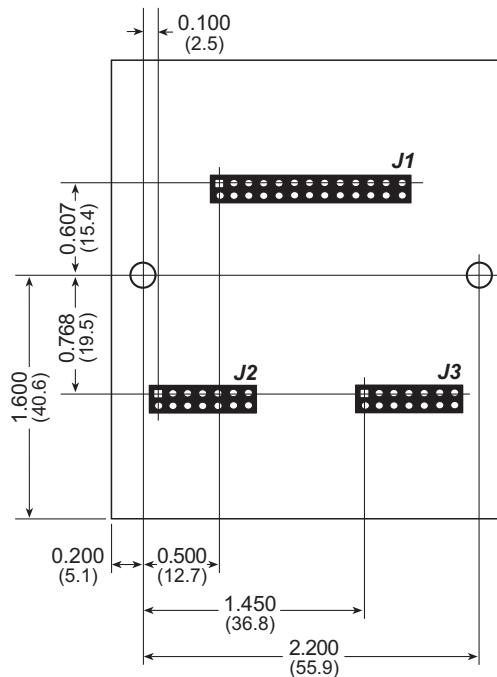

Figure C-2. User Board Footprint for LCD/Keypad Module

C.2 Contrast Adjustments for All Boards

Starting in 2005, LCD/keypad modules were factory-configured to optimize their contrast based on the voltage of the system they would be used in. Be sure to select a KDU5V LCD/keypad module for use with the RCM3000/3100/3200 Prototyping Board — these modules operate at 5 V. You may adjust the contrast using the potentiometer at R2 as shown in Figure C-3. LCD/keypad modules configured for 3.3 V should not be used with the 5 V RCM3000/3100/3200 Prototyping Board because the higher voltage will reduce the backlight service life dramatically.

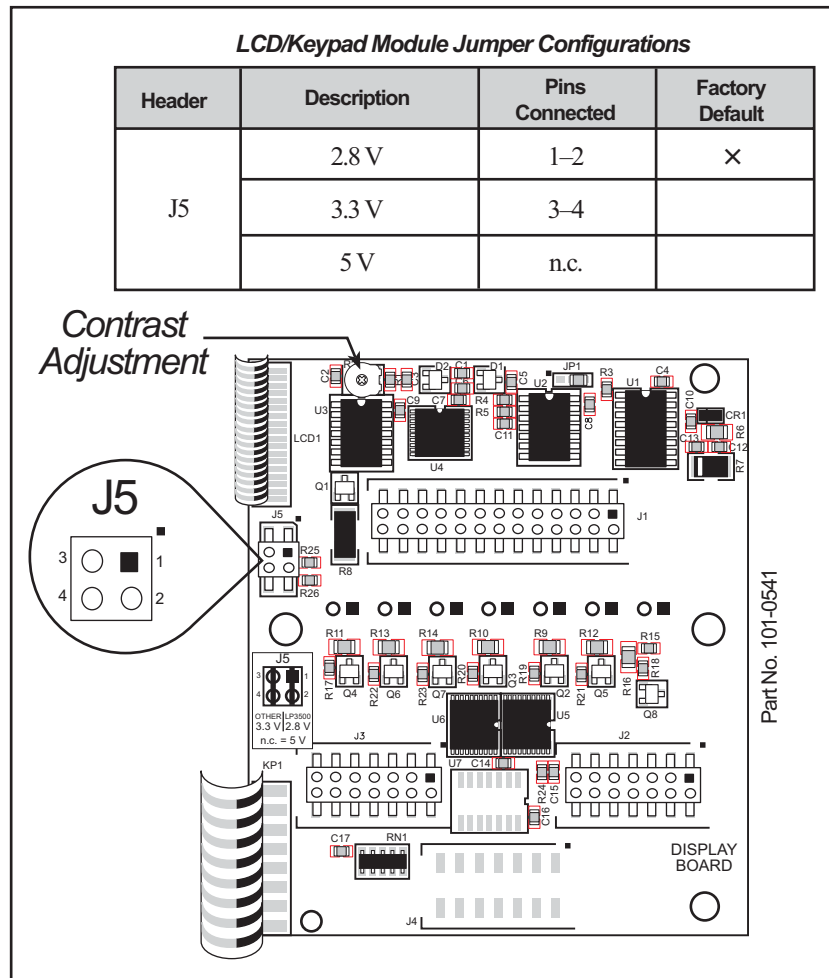

Figure C-3. LCD/Keypad Module Voltage Settings

You can set the contrast on the LCD display of pre-2005 LCD/keypad modules by adjusting the potentiometer at R2 or by setting the voltage for 5 V by removing the jumper across pins 1–2 on header J5 as shown in Figure C-3. Only one of these two options is available on these LCD/keypad modules.

NOTE: Older LCD/keypad modules that do not have a header at J5 or a contrast adjustment potentiometer at R2 are limited to operate only at 5 V, and will work with the Prototyping Board. The older LCD/keypad modules are no longer being sold.

C.3 Keypad Labeling

The keypad may be labeled according to your needs. A template is provided in Figure C-4 to allow you to design your own keypad label insert.

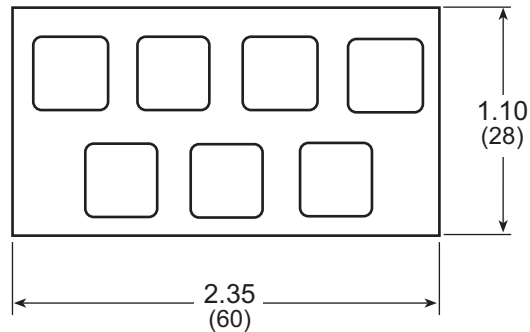

Figure C-4. Keypad Template

To replace the keypad legend, remove the old legend and insert your new legend prepared according to the template in Figure C-4. The keypad legend is located under the blue keypad matte, and is accessible from the left only as shown in Figure C-5.

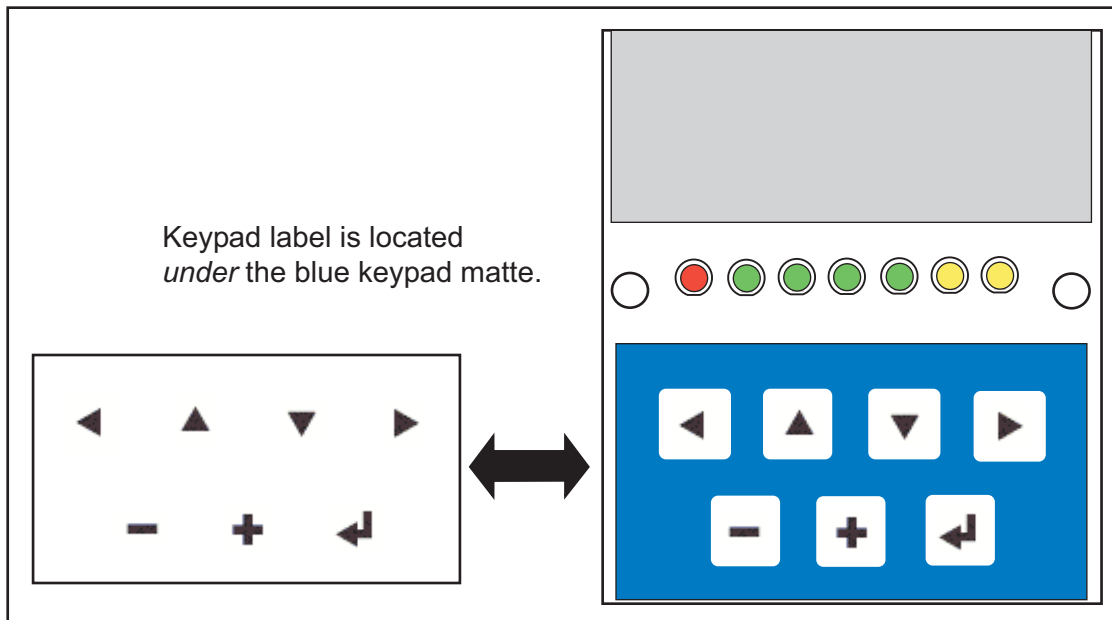

Figure C-5. Removing and Inserting Keypad Label

C.4 Header Pinouts

Figure C-6 shows the pinouts for the LCD/keypad module.

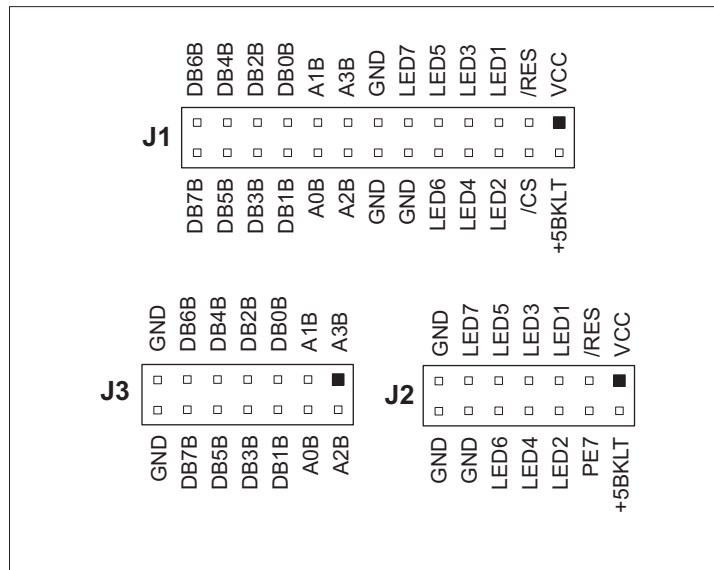

Figure C-6. LCD/Keypad Module Pinouts

C.4.1 I/O Address Assignments

The LCD and keypad on the LCD/keypad module are addressed by the /CS strobe as explained in Table C-2.

Table C-2. LCD/Keypad Module Address Assignment

Address	Function
0xC000	Device select base address (/CS)
0xCxx0–0xCxx7	LCD control
0xCxx8	LED enable
0xCxx9	Not used
0xCxxA	7-key keypad
0xCxxB (bits 0–6)	7-LED driver
0xCxxB (bit 7)	LCD backlight on/off
0xCxxC–ExxF	Not used

C.5 Mounting LCD/Keypad Module on the Prototyping Board

Install the LCD/keypad module on header sockets J7, J8, and J10 of the Prototyping Board as shown in Figure C-7. Be careful to align the pins over the headers, and do not bend them as you press down to mate the LCD/keypad module with the Prototyping Board.

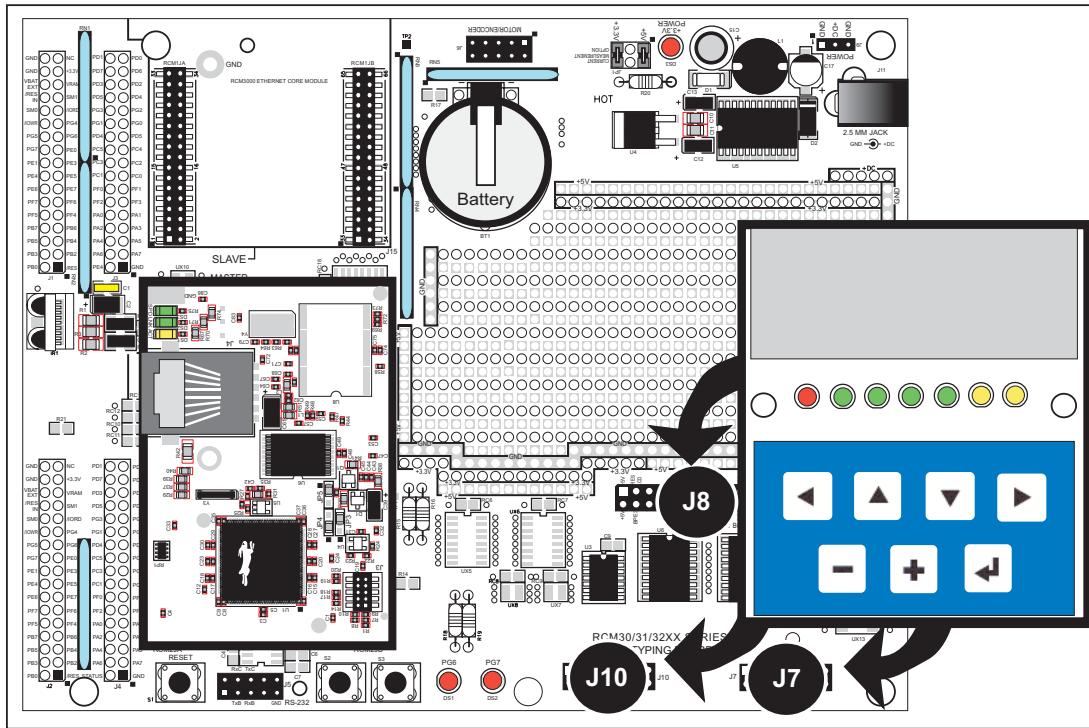

Figure C-7. Install LCD/Keypad Module on Prototyping Board

C.6 Bezel-Mount Installation

This section describes and illustrates how to bezel-mount the LCD/keypad module. Follow these steps for bezel-mount installation.

1. Cut mounting holes in the mounting panel in accordance with the recommended dimensions in Figure C-8, then use the bezel faceplate to mount the LCD/keypad module onto the panel.

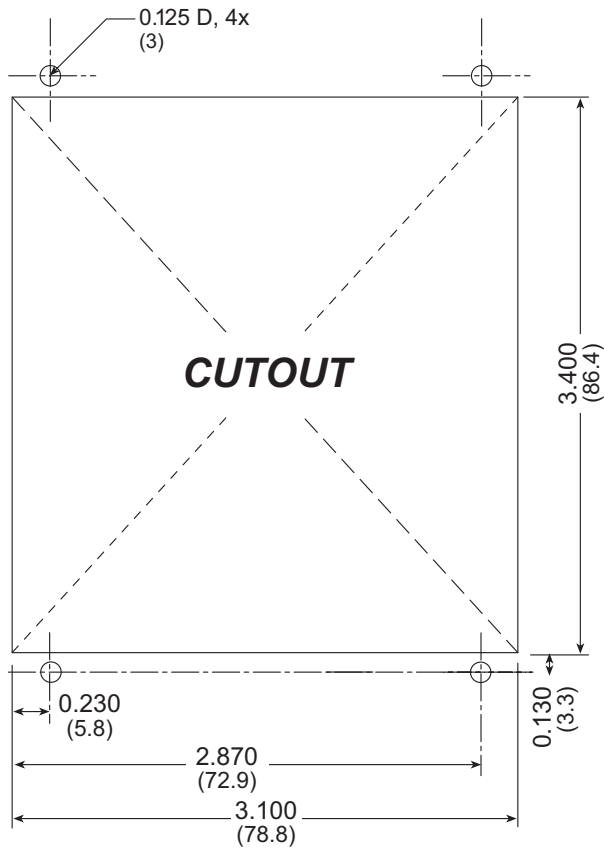

Figure C-8. Recommended Cutout Dimensions

2. Carefully “drop in” the LCD/keypad module with the bezel and gasket attached.

3. Fasten the unit with the four 4-40 screws and washers included with the LCD/keypad module. If your panel is thick, use a 4-40 screw that is approximately 3/16" (5 mm) longer than the thickness of the panel.

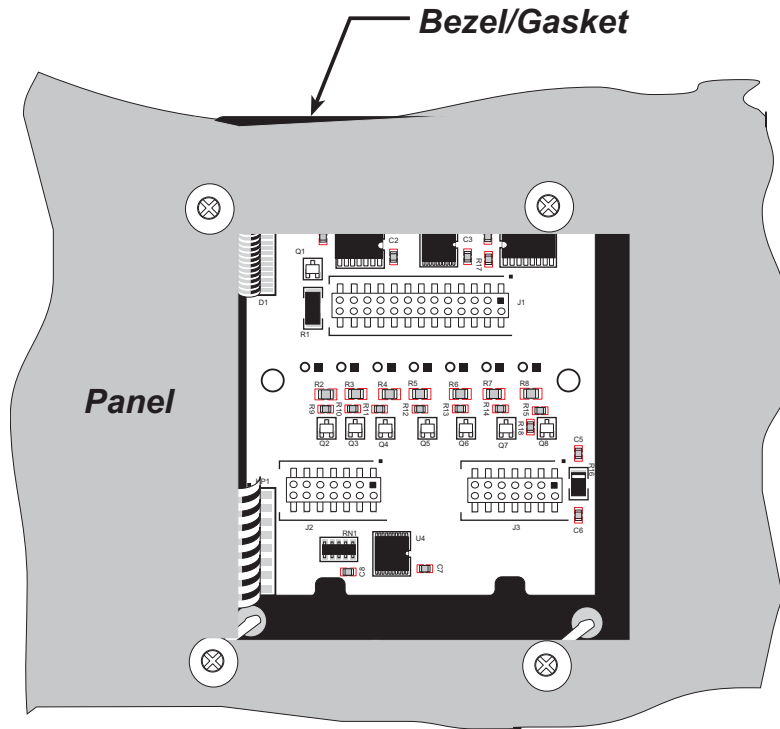

Figure C-9. LCD/Keypad Module Mounted in Panel (rear view)

Carefully tighten the screws until the gasket is compressed and the plastic bezel faceplate is touching the panel.

Do not tighten each screw fully before moving on to the next screw. Apply only one or two turns to each screw in sequence until all are tightened manually as far as they can be so that the gasket is compressed and the plastic bezel faceplate is touching the panel.

C.6.1 Connect the LCD/Keypad Module to Your Prototyping Board

The LCD/keypad module can be located as far as 2 ft. (60 cm) away from the RCM30/31/32XX Prototyping Board, and is connected via a ribbon cable as shown in Figure C-10.

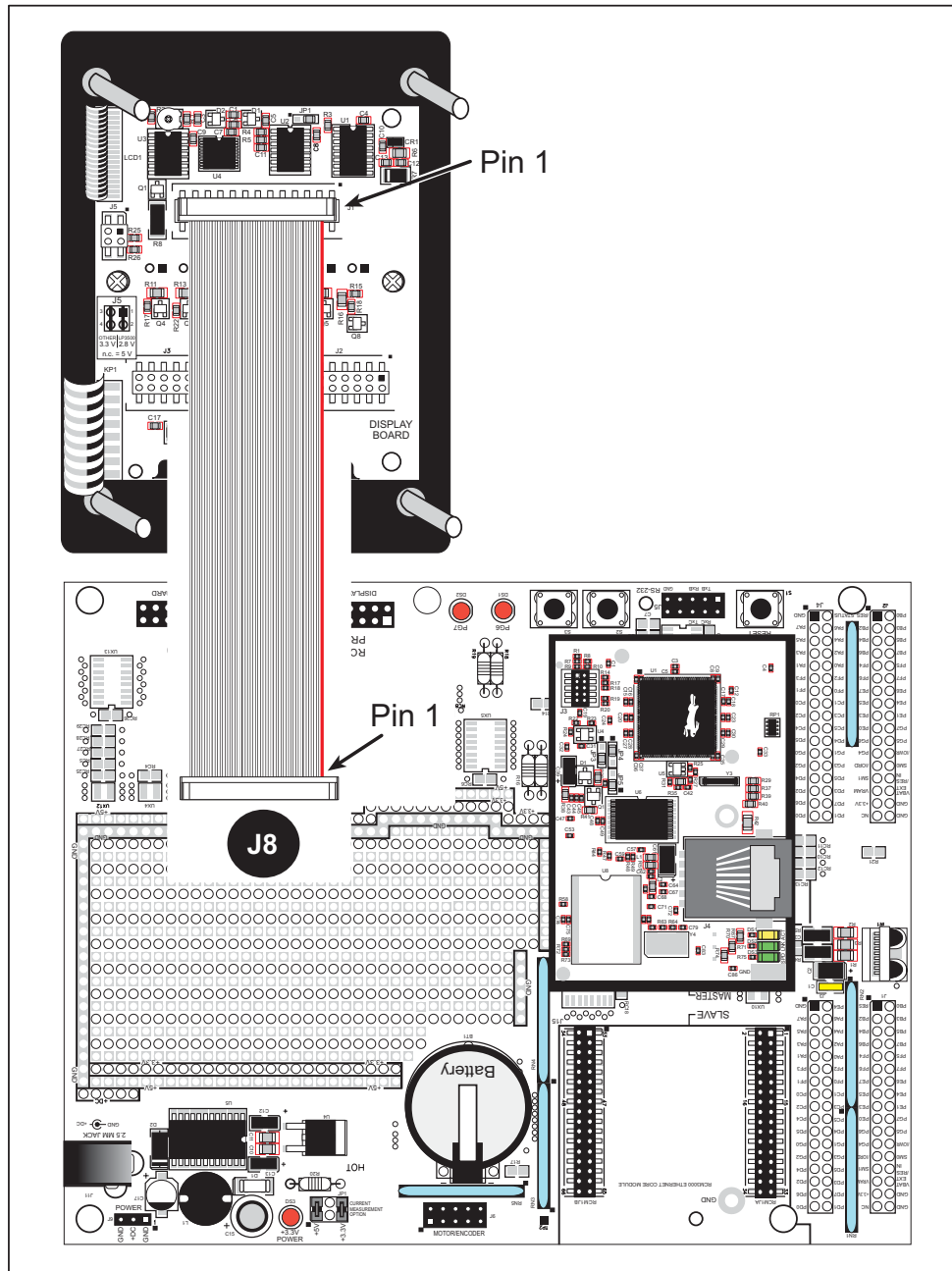

Figure C-10. Connecting LCD/Keypad Module to RCM30/31/32XX Prototyping Board

Note the locations and connections relative to pin 1 on both the Prototyping Board and the LCD/keypad module.

Rabbit offers 2 ft. (60 cm) extension cables. Contact your authorized Rabbit distributor or a sales representative for more information.

C.7 LCD/Keypad Module Function Calls

When mounted on the Prototyping Board, the LCD/keypad module uses the external I/O bus on the Rabbit 3000 chip. Remember to add the line

```
#define PORTA_AUX_IO
```

to the beginning of any programs using the external I/O bus.

C.7.1 LCD/Keypad Module Initialization

The function used to initialize the LCD/keypad module can be found in the Dynamic C `LIB\DISPLAYS\LCD122KEY7.LIB` library.

```
void dispInit();
```

Initializes the LCD/keypad module. The keypad is set up using `keypadDef()` or `keyConfig()` after this function call.

RETURN VALUE

None.

C.7.2 LEDs

When power is applied to the LCD/keypad module for the first time, the red LED (DS1) will come on, indicating that power is being applied to the LCD/keypad module. The red LED is turned off when the `brdInit` function executes.

One function is available to control the LEDs, and can be found in the `LIB\DISPLAYS\LCD122KEY7.LIB` library.

```
void ledOut(int led, int value);
```

LED on/off control. This function will only work when the LCD/keypad module is installed on the Prototyping Board.

PARAMETERS

`led` is the LED to control.

0 = LED DS1

1 = LED DS2

2 = LED DS3

3 = LED DS4

4 = LED DS5

5 = LED DS6

6 = LED DS7

`value` is the value used to control whether the LED is on or off (0 or 1).

0 = off

1 = on

RETURN VALUE

None.

C.7.3 LCD Display

The functions used to control the LCD display are contained in the **GRAPHIC.LIB** library located in the Dynamic C **DISPLAYS\GRAPHIC** library directory.

```
void glInit(void);
```

Initializes the display devices, clears the screen.

RETURN VALUE

None.

SEE ALSO

`glDispOnOFF`, `glBacklight`, `glSetContrast`, `glPlotDot`, `glBlock`, `glPlotDot`,
`glPlotPolygon`, `glPlotCircle`, `glHScroll`, `glVScroll`, `glXFontInit`, `glPrintf`,
`glPutChar`, `glSetBrushType`, `glBuffLock`, `glBuffUnlock`, `glPlotLine`

```
void glBackLight(int onOff);
```

Turns the display backlight on or off.

PARAMETER

`onOff` turns the backlight on or off

1—turn the backlight on

0—turn the backlight off

RETURN VALUE

None.

SEE ALSO

`glInit`, `glDispOnoff`, `glSetContrast`

```
void glDispOnOff(int onOff);
```

Sets the LCD screen on or off. Data will not be cleared from the screen.

PARAMETER

`onOff` turns the LCD screen on or off

1—turn the LCD screen on

0—turn the LCD screen off

RETURN VALUE

None.

SEE ALSO

`glInit`, `glSetContrast`, `glBackLight`

```
void glSetContrast(unsigned level);
```

Sets display contrast.

NOTE: This function is not used with the LCD/keypad module since the support circuits are not available on the LCD/keypad module.

```
void glFillScreen(char pattern);
```

Fills the LCD display screen with a pattern.

PARAMETER

The screen will be set to all black if **pattern** is 0xFF, all white if **pattern** is 0x00, and vertical stripes for any other pattern.

RETURN VALUE

None.

SEE ALSO

`glBlock`, `glBlankScreen`, `glPlotPolygon`, `glPlotCircle`

```
void glBlankScreen(void);
```

Blanks the LCD display screen (sets LCD display screen to white).

RETURN VALUE

None.

SEE ALSO

`glFillScreen`, `glBlock`, `glPlotPolygon`, `glPlotCircle`

```
void glBlock(int x, int y, int bmWidth,  
int bmHeight);
```

Draws a rectangular block in the page buffer and on the LCD if the buffer is unlocked. Any portion of the block that is outside the LCD display area will be clipped.

PARAMETERS

x is the *x* coordinate of the top left corner of the block.

y is the *y* coordinate of the top left corner of the block.

bmWidth is the width of the block.

bmHeight is the height of the block.

RETURN VALUE

None.

SEE ALSO

`glFillScreen`, `glBlankScreen`, `glPlotPolygon`, `glPlotCircle`

```
void glPlotVPolygon(int n, int *pFirstCoord);
```

Plots the outline of a polygon in the LCD page buffer, and on the LCD if the buffer is unlocked. Any portion of the polygon that is outside the LCD display area will be clipped. If fewer than 3 vertices are specified, the function will return without doing anything.

PARAMETERS

n is the number of vertices.

***pFirstCoord** is a pointer to array of vertex coordinates: **x1,y1, x2,y2, x3,y3,...**

RETURN VALUE

None.

SEE ALSO

`glPlotPolygon, glFillPolygon, glFillVPolygon`

```
void glPlotPolygon(int n, int y1, int x2, int y2,  
...);
```

Plots the outline of a polygon in the LCD page buffer and on the LCD if the buffer is unlocked. Any portion of the polygon that is outside the LCD display area will be clipped. If fewer than 3 vertices are specified, the function will return without doing anything.

PARAMETERS

n is the number of vertices.

y1 is the y coordinate of the first vertex.

x1 is the x coordinate of the first vertex.

y2 is the y coordinate of the second vertex.

x2 is the x coordinate of the second vertex.

... are the coordinates of additional vertices.

RETURN VALUE

None.

SEE ALSO

`glPlotVPolygon, glFillPolygon, glFillVPolygon`

```
void glFillVPolygon(int n, int *pFirstCoord);
```

Fills a polygon in the LCD page buffer and on the LCD screen if the buffer is unlocked. Any portion of the polygon that is outside the LCD display area will be clipped. If fewer than 3 vertices are specified, the function will return without doing anything.

PARAMETERS

n is the number of vertices.

***pFirstCoord** is a pointer to array of vertex coordinates: **x1,y1, x2,y2, x3,y3,...**

RETURN VALUE

None.

SEE ALSO

`glFillPolygon, glPlotPolygon, glPlotVPolygon`

```
void glFillPolygon(int n, int x1, int y1, int x2,  
int y2, ...);
```

Fills a polygon in the LCD page buffer and on the LCD if the buffer is unlocked. Any portion of the polygon that is outside the LCD display area will be clipped. If fewer than 3 vertices are specified, the function will return without doing anything.

PARAMETERS

n is the number of vertices.

x1 is the *x* coordinate of the first vertex.

y1 is the *y* coordinate of the first vertex.

x2 is the *x* coordinate of the second vertex.

y2 is the *y* coordinate of the second vertex.

... are the coordinates of additional vertices.

RETURN VALUE

None.

SEE ALSO

`glFillVPolygon, glPlotPolygon, glPlotVPolygon`

```
void glPlotCircle(int xc, int yc, int rad);
```

Draws the outline of a circle in the LCD page buffer and on the LCD if the buffer is unlocked. Any portion of the circle that is outside the LCD display area will be clipped.

PARAMETERS

xc is the *x* coordinate of the center of the circle.

yc is the *y* coordinate of the center of the circle.

rad is the radius of the center of the circle (in pixels).

RETURN VALUE

None.

SEE ALSO

`glFillCircle, glPlotPolygon, glFillPolygon`

```
void glFillColor(int xc, int yc, int rad);
```

Draws a filled circle in the LCD page buffer and on the LCD if the buffer is unlocked. Any portion of the circle that is outside the LCD display area will be clipped.

PARAMETERS

xc is the *x* coordinate of the center of the circle.

yc is the *y* coordinate of the center of the circle.

rad is the radius of the center of the circle (in pixels).

RETURN VALUE

None.

SEE ALSO

`glPlotCircle`, `glPlotPolygon`, `glFillPolygon`

```
void glXFontInit(fontInfo *pInfo, char pixWidth,  
char pixHeight, unsigned startChar,  
unsigned endChar, unsigned long xmemBuffer);
```

Initializes the font descriptor structure, where the font is stored in **xmem**.

PARAMETERS

***pInfo** is a pointer to the font descriptor to be initialized.

pixWidth is the width (in pixels) of each font item.

pixHeight is the height (in pixels) of each font item.

startChar is the value of the first printable character in the font character set.

endChar is the value of the last printable character in the font character set.

xmemBuffer is the **xmem** pointer to a linear array of font bitmaps.

RETURN VALUE

None.

SEE ALSO

`glPrintf`

```
unsigned long glFontCharAddr(fontInfo *pInfo,  
char letter);
```

Returns the **xmem** address of the character from the specified font set.

PARAMETERS

***pInfo** is the **xmem** address of the bitmap font set.

letter is an ASCII character.

RETURN VALUE

xmem address of bitmap character font, column major, and byte-aligned.

SEE ALSO

`glPutFont`, `glPrintf`

```
void glPutFont(int x, int y, fontInfo *pInfo,  
char code);
```

Puts an entry from the font table to the page buffer and on the LCD if the buffer is unlocked. Each font character's bitmap is column major and byte-aligned. Any portion of the bitmap character that is outside the LCD display area will be clipped.

PARAMETERS

x is the *x* coordinate (column) of the top left corner of the text.

y is the *y* coordinate (row) of the top left corner of the text.

***pInfo** is a pointer to the font descriptor.

code is the ASCII character to display.

RETURN VALUE

None.

SEE ALSO

`glFontCharAddr`, `glPrintf`

```
void glSetPfStep(int stepX, int stepY);
```

Sets the `glPrintf()` printing step direction. The *x* and *y* step directions are independent signed values. The actual step increments depend on the height and width of the font being displayed, which are multiplied by the step values.

PARAMETERS

stepX is the `glPrintf` *x* step value

stepY is the `glPrintf` *y* step value

RETURN VALUE

None.

SEE ALSO

Use `glGetPfStep()` to examine the current *x* and *y* printing step direction.

```
int glGetPfStep(void);
```

Gets the current `glPrintf()` printing step direction. Each step direction is independent of the other, and is treated as an 8-bit signed value. The actual step increments depends on the height and width of the font being displayed, which are multiplied by the step values.

RETURN VALUE

The *x* step is returned in the MSB, and the *y* step is returned in the LSB of the integer result.

SEE ALSO

Use `glGetPfStep()` to control the *x* and *y* printing step direction.

```
void glPutChar(char ch, char *ptr, int *cnt,
               glPutCharInst *pInst)
```

Provides an interface between the **STDIO** string-handling functions and the graphic library. The **STDIO** string-formatting function will call this function, one character at a time, until the entire formatted string has been parsed. Any portion of the bitmap character that is outside the LCD display area will be clipped.

PARAMETERS

- ch** is the character to be displayed on the LCD.
- *ptr** is not used, but is a place holder for **STDIO** string functions.
- *cnt** is not used, is a place holder for **STDIO** string functions.
- *pInst** is a font descriptor pointer.

RETURN VALUE

None.

SEE ALSO

`glPrintf`, `glPutFont`, `doprnt`

```
void glPrintf(int x, int y, fontInfo *pInfo,
              char *fmt, ...);
```

Prints a formatted string (much like `printf`) on the LCD screen. Only the character codes that exist in the font set are printed, all others are skipped. For example, `'\b'`, `'\t'`, `'\n'` and `'\r'` (ASCII backspace, tab, new line, and carriage return, respectively) will be printed if they exist in the font set, but will not have any effect as control characters. Any portion of the bitmap character that is outside the LCD display area will be clipped.

PARAMETERS

- x** is the *x* coordinate (column) of the top left corner of the text.
- y** is the *y* coordinate (row) of the top left corner of the text.
- *pInfo** is a font descriptor pointer.
- *fmt** is a formatted string.
- ...** are formatted string conversion parameter(s).

EXAMPLE

```
glprintf(0,0, &fi12x16, "Test %d\n", count);
```

RETURN VALUE

None.

SEE ALSO

`glXFontInit`

void glBuffLock(void);

Increments LCD screen locking counter. Graphic calls are recorded in the LCD memory buffer and are not transferred to the LCD if the counter is non-zero.

NOTE: `glBuffLock()` and `glBuffUnlock()` can be nested up to a level of 255, but be sure to balance the calls. It is not a requirement to use these procedures, but a set of `glBuffLock()` and `glBuffUnlock()` bracketing a set of related graphic calls speeds up the rendering significantly.

RETURN VALUE

None.

SEE ALSO

`glBuffUnlock`, `glSwap`

void glBuffUnlock(void);

Decrements the LCD screen locking counter. The contents of the LCD buffer are transferred to the LCD if the counter goes to zero.

RETURN VALUE

None.

SEE ALSO

`glBuffLock`, `glSwap`

void glSwap(void);

Checks the LCD screen locking counter. The contents of the LCD buffer are transferred to the LCD if the counter is zero.

RETURN VALUE

None.

SEE ALSO

`glBuffUnlock`, `glBuffLock`, `_glSwapData` (located in the library specifically for the LCD that you are using)

void glSetBrushType(int type);

Sets the drawing method (or color) of pixels drawn by subsequent graphic calls.

PARAMETER

`type` value can be one of the following macros.

`PIXBLACK` draws black pixels.

`PIXWHITE` draws white pixels.

`PIXXOR` draws old pixel XOR'ed with the new pixel.

RETURN VALUE

None.

SEE ALSO

`glGetBrushType`

```
int glGetBrushType(void);
```

Gets the current method (or color) of pixels drawn by subsequent graphic calls.

RETURN VALUE

The current brush type.

SEE ALSO

`glSetBrushType`

```
void glPlotDot(int x, int y);
```

Draws a single pixel in the LCD buffer, and on the LCD if the buffer is unlocked. If the coordinates are outside the LCD display area, the dot will not be plotted.

PARAMETERS

x is the x coordinate of the dot.

y is the y coordinate of the dot.

RETURN VALUE

None.

SEE ALSO

`glPlotline`, `glPlotPolygon`, `glPlotCircle`

```
void glPlotLine(int x0, int y0, int x1, int y1);
```

Draws a line in the LCD buffer, and on the LCD if the buffer is unlocked. Any portion of the line that is beyond the LCD display area will be clipped.

PARAMETERS

x0 is the x coordinate of one endpoint of the line.

y0 is the y coordinate of one endpoint of the line.

x1 is the x coordinate of the other endpoint of the line.

y1 is the y coordinate of the other endpoint of the line.

RETURN VALUE

None.

SEE ALSO

`glPlotDot`, `glPlotPolygon`, `glPlotCircle`

```
void glLeft1(int left, int top, int cols, int rows);
```

Scrolls byte-aligned window left one pixel, right column is filled by current pixel type (color).

PARAMETERS

left is the top left corner of bitmap, must be evenly divisible by 8, otherwise truncates.

top is the top left corner of the bitmap.

cols is the number of columns in the window, must be evenly divisible by 8, otherwise truncates.

rows is the number of rows in the window.

RETURN VALUE

None.

SEE ALSO

`glHScroll`, `glRight1`

```
void glRight1(int left, int top, int cols, int rows);
```

Scrolls byte-aligned window right one pixel, left column is filled by current pixel type (color).

PARAMETERS

left is the top left corner of bitmap, must be evenly divisible by 8, otherwise truncates.

top is the top left corner of the bitmap.

cols is the number of columns in the window, must be evenly divisible by 8, otherwise truncates.

rows is the number of rows in the window.

RETURN VALUE

None.

SEE ALSO

`glHScroll`, `glLeft1`

```
void glUp1(int left, int top, int cols, int rows);
```

Scrolls byte-aligned window up one pixel, bottom column is filled by current pixel type (color).

PARAMETERS

left is the top left corner of bitmap, must be evenly divisible by 8, otherwise truncates.

top is the top left corner of the bitmap.

cols is the number of columns in the window, must be evenly divisible by 8, otherwise truncates.

rows is the number of rows in the window.

RETURN VALUE

None.

SEE ALSO

`glVScroll`, `glDown1`

```
void glDown1(int left, int top, int cols, int rows);
```

Scrolls byte-aligned window down one pixel, top column is filled by current pixel type (color).

PARAMETERS

left is the top left corner of bitmap, must be evenly divisible by 8, otherwise truncates.

top is the top left corner of the bitmap.

cols is the number of columns in the window, must be evenly divisible by 8, otherwise truncates.

rows is the number of rows in the window.

RETURN VALUE

None.

SEE ALSO

`glVScroll`, `glUp1`

```
void glHScroll(int left, int top, int cols,  
int rows, int nPix);
```

Scrolls right or left, within the defined window by *x* number of pixels. The opposite edge of the scrolled window will be filled in with white pixels. The window must be byte-aligned.

Parameters will be verified for the following:

1. The **left** and **cols** parameters will be verified that they are evenly divisible by 8. If not, they will be truncated to a value that is a multiple of 8.
2. Parameters will be checked to verify that the scrolling area is valid. The minimum scrolling area is a width of 8 pixels and a height of one row.

PARAMETERS

left is the top left corner of bitmap, must be evenly divisible by 8.

top is the top left corner of the bitmap.

cols is the number of columns in the window, must be evenly divisible by 8.

rows is the number of rows in the window.

nPix is the number of pixels to scroll within the defined window (a negative value will produce a scroll to the left).

RETURN VALUE

None.

SEE ALSO

`glVScroll`

```
void glVScroll(int left, int top, int cols,
               int rows, int nPix);
```

Scrolls up or down, within the defined window by x number of pixels. The opposite edge of the scrolled window will be filled in with white pixels. The window must be byte-aligned.

Parameters will be verified for the following:

1. The **left** and **cols** parameters will be verified that they are evenly divisible by 8. If not, they will be truncated to a value that is a multiple of 8.
2. Parameters will be checked to verify that the scrolling area is valid. The minimum scrolling area is a width of 8 pixels and a height of one row.

PARAMETERS

left is the top left corner of bitmap, must be evenly divisible by 8.

top is the top left corner of the bitmap.

cols is the number of columns in the window, must be evenly divisible by 8.

rows is the number of rows in the window.

nPix is the number of pixels to scroll within the defined window (a negative value will produce a scroll up).

RETURN VALUE

None.

SEE ALSO

`glHScroll`

```
void glXPutBitmap(int left, int top, int width,
                  int height, unsigned long bitmap);
```

Draws bitmap in the specified space. The data for the bitmap are stored in **xmem**. This function calls `glXPutFastmap` automatically if the bitmap is byte-aligned (the left edge and the width are each evenly divisible by 8).

Any portion of a bitmap image or character that is outside the LCD display area will be clipped.

PARAMETERS

left is the top left corner of the bitmap.

top is the top left corner of the bitmap.

width is the width of the bitmap.

height is the height of the bitmap.

bitmap is the address of the bitmap in **xmem**.

RETURN VALUE

None.

SEE ALSO

`glXPutFastmap`, `glPrintf`

```
void glXPutFastmap(int left, int top, int width,
                  int height, unsigned long bitmap);
```

Draws bitmap in the specified space. The data for the bitmap are stored in `xmem`. This function is like `glXPutBitmap`, except that it is faster. The restriction is that the bitmap must be byte-aligned.

Any portion of a bitmap image or character that is outside the LCD display area will be clipped.

PARAMETERS

`left` is the top left corner of the bitmap, must be evenly divisible by 8, otherwise truncates.

`top` is the top left corner of the bitmap.

`width` is the width of the bitmap, must be evenly divisible by 8, otherwise truncates.

`height` is the height of the bitmap.

`bitmap` is the address of the bitmap in `xmem`.

RETURN VALUE

None.

SEE ALSO

`glXPutBitmap`, `glPrintf`

```
int TextWindowFrame(windowFrame *window,
                   fontInfo *pFont, int x, int y, int winWidth,
                   int winHeight)
```

Defines a text-only display window. This function provides a way to display characters within the text window using only character row and column coordinates. The text window feature provides end-of-line wrapping and clipping after the character in the last column and row is displayed.

NOTE: Execute the `TextWindowFrame` function before other `Text...` functions.

PARAMETERS

`*window` is a window frame descriptor pointer.

`*pFont` is a font descriptor pointer.

`x` is the *x* coordinate of where the text window frame is to start.

`y` is the *y* coordinate of where the text window frame is to start.

`winWidth` is the width of the text window frame.

`winHeight` is the height of the text window frame.

RETURN VALUE

0—window frame was successfully created.

-1—*x* coordinate + width has exceeded the display boundary.

-2—*y* coordinate + height has exceeded the display boundary.

```
void TextGotoXY(windowFrame *window, int col,  
int row);
```

Sets the cursor location on the display of where to display the next character. The display location is based on the height and width of the character to be displayed.

NOTE: Execute the `TextWindowFrame` function before using this function.

PARAMETERS

`*window` is a pointer to a font descriptor.

`col` is a character column location.

`row` is a character row location.

RETURN VALUE

None.

SEE ALSO

`TextPutChar`, `TextPrintf`, `TextWindowFrame`

```
void TextCursorPosition(windowFrame *window,  
int *col, int *row);
```

Gets the current cursor location that was set by a Graphic `Text...` function.

NOTE: Execute the `TextWindowFrame` function before using this function.

PARAMETERS

`*window` is a pointer to a font descriptor.

`*col` is a pointer to cursor column variable.

`*row` is a pointer to cursor row variable.

RETURN VALUE

Lower word = Cursor Row location

Upper word = Cursor Column location

SEE ALSO

`TextGotoXY`, `TextPrintf`, `TextWindowFrame`, `TextCursorPosition`

```
void TextPutChar(struct windowFrame *window, char ch);
```

Displays a character on the display where the cursor is currently pointing. If any portion of a bitmap character is outside the LCD display area, the character will not be displayed.

NOTE: Execute the `TextWindowFrame` function before using this function.

PARAMETERS

`*window` is a pointer to a font descriptor.

`ch` is a character to be displayed on the LCD.

RETURN VALUE

None.

SEE ALSO

`TextGotoXY`, `TextPrintf`, `TextWindowFrame`, `TextCursorPosition`

```
void TextPrintf(struct windowFrame *window,  
char *fmt, ...);
```

Prints a formatted string (much like `printf`) on the LCD screen. Only printable characters in the font set are printed, also escape sequences, `\r` and `\n` are recognized. All other escape sequences will be skipped over; for example, `\b` and `\t` will print if they exist in the font set, but will not have any effect as control characters.

The text window feature provides end-of-line wrapping and clipping after the character in the last column and row is displayed.

NOTE: Execute the `TextWindowFrame` function before using this function.

PARAMETERS

`*window` is a pointer to a font descriptor.

`*fmt` is a formatted string.

`...` are formatted string conversion parameter(s).

EXAMPLE

```
TextPrintf(&TextWindow, "Test %d\n", count);
```

RETURN VALUE

None.

SEE ALSO

`TextGotoXY`, `TextPutChar`, `TextWindowFrame`, `TextCursorPosition`

C.7.4 Keypad

The functions used to control the keypad are contained in the Dynamic C `LIB\KEYPADS\KEYPAD7.LIB` library.

```
void keyInit(void);
```

Initializes keypad process

RETURN VALUE

None.

SEE ALSO

`brdInit`

```
void keyConfig(char cRaw, char cPress,  
char cRelease, char cCntHold, char cSpdLo,  
char cCntLo, char cSpdHi);
```

Assigns each key with key press and release codes, and hold and repeat ticks for auto repeat and debouncing.

PARAMETERS

`cRaw` is a raw key code index.

1x7 keypad matrix with raw key code index assignments (in brackets):

[0]	[1]	[2]	[3]
[4]	[5]	[6]	

User Keypad Interface

`cPress` is a key press code

An 8-bit value is returned when a key is pressed.

0 = Unused.

See `keypadDef()` for default press codes.

`cRelease` is a key release code.

An 8-bit value is returned when a key is pressed.

0 = Unused.

`cCntHold` is a hold tick.

How long to hold before repeating.

0 = No Repeat.

`cSpdLo` is a low-speed repeat tick.

How many times to repeat.

0 = None.

`cCntLo` is a low-speed hold tick.

How long to hold before going to high-speed repeat.

0 = Slow Only.

`cSpdHi` is a high-speed repeat tick.

How many times to repeat after low speed repeat.

0 = None.

RETURN VALUE

None.

SEE ALSO

`keyProcess`, `keyGet`, `keypadDef`

`void keyProcess(void);`

Scans and processes keypad data for key assignment, debouncing, press and release, and repeat.

NOTE: This function is also able to process an 8×8 matrix keypad.

RETURN VALUE

None

SEE ALSO

`keyConfig`, `keyGet`, `keypadDef`

`char keyGet(void);`

Get next keypress

RETURN VALUE

The next keypress, or 0 if none

SEE ALSO

`keyConfig`, `keyProcess`, `keypadDef`

`int keyUnget(char cKey);`

Push keypress on top of input queue

PARAMETER

`cKey`

RETURN VALUE

None.

SEE ALSO

`keyGet`

`void keypadDef();`

Configures the physical layout of the keypad with the desired ASCII return key codes.

Keypad physical mapping 1 × 7

0	4	1	5	2	6	3
['L']		['U']		['D']		['R']
	['-']		['+']		['E']	

where

'E' represents the ENTER key

'D' represents Down Scroll

'U' represents Up Scroll

'R' represents Right Scroll

'L' represents Left Scroll

Example: Do the following for the above physical vs. ASCII return key codes.

```
keyConfig ( 3, 'R', 0, 0, 0, 0, 0 );  
keyConfig ( 6, 'E', 0, 0, 0, 0, 0 );  
keyConfig ( 2, 'D', 0, 0, 0, 0, 0 );  
keyConfig ( 4, '-', 0, 0, 0, 0, 0 );  
keyConfig ( 1, 'U', 0, 0, 0, 0, 0 );  
keyConfig ( 5, '+', 0, 0, 0, 0, 0 );  
keyConfig ( 0, 'L', 0, 0, 0, 0, 0 );
```

Characters are returned upon keypress with no repeat.

RETURN VALUE

None.

SEE ALSO

`keyConfig`, `keyGet`, `keyProcess`

`void keyScan(char *pcKeys);`

Writes "1" to each row and reads the value. The position of a keypress is indicated by a zero value in a bit position.

PARAMETER

***pcKeys** is the address of the value read.

RETURN VALUE

None.

SEE ALSO

`keyConfig`, `keyGet`, `keypadDef`, `keyProcess`

C.8 Sample Programs

Sample programs illustrating the use of the LCD/keypad module with the Prototyping Board are provided in the `SAMPLES\RCM3200` directory.

These sample programs use the external I/O bus on the Rabbit 3000 chip, and so the `#define PORTA_AUX_IO` line is already included in the sample programs.

Each sample program has comments that describe the purpose and function of the program. Follow the instructions at the beginning of the sample program. To run a sample program, open it with the **File** menu (if it is not still open), compile it using the **Compile** menu, and then run it by selecting **Run** in the **Run** menu. The RCM3200 must be in **Program** mode (see Section 4.3, “Serial Programming Cable”), and must be connected to a PC using the programming cable as described in the *RCM3200 Getting Started Manual*.

More complete information on Dynamic C is provided in the *Dynamic C User’s Manual*.

The following sample programs are found in the `SAMPLES\RCM3200\LCD_KEYPAD` folder.

- **KEYPADTOLED.C**—This program demonstrates the use of the external I/O bus. The program will light up an LED on the LCD/keypad module and will display a message on the LCD when a key press is detected. The DS1 and DS2 LEDs on the Prototyping Board will also light up.
- **LCDKEYFUN.C**—This program demonstrates how to draw primitive features from the graphic library (lines, circles, polygons), and also demonstrates the keypad with the key release option.
- **SWITCHTOLED.C**—This program demonstrates the use of the external I/O bus. The program will light up an LED on the LCD/keypad module and will display a message on the LCD when a switch press is detected. The DS1 and DS2 LEDs on the Prototyping Board will also light up.

APPENDIX D. POWER SUPPLY

Appendix D provides information on the current requirements of the RCM3200, and includes some background on the chip select circuit used in power management.

D.1 Power Supplies

The RCM3200 requires a regulated $3.3\text{ V} \pm 0.15\text{ V}$ DC power source. The RabbitCore design presumes that the voltage regulator is on the user board, and that the power is made available to the RCM3200 board through header J2.

An RCM3200 with no loading at the outputs operating at 29.4 MHz typically draws 145 mA. The RCM3200 will consume an additional 10 mA when the programming cable is used to connect the programming header, J3, to a PC.

D.1.1 Battery Backup

The RCM3200 does not have a battery, but there is provision for a customer-supplied battery to back up the data SRAM and keep the internal Rabbit 3000 real-time clock running.

Header J2, shown in Figure D-1, allows access to the external battery. This header makes it possible to connect an external 3 V power supply. This allows the SRAM and the internal Rabbit 3000 real-time clock to retain data with the RCM3200 powered down.

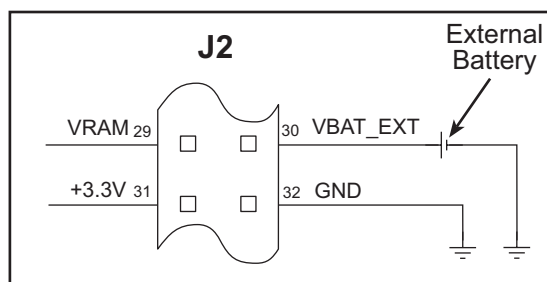

Figure D-1. External Battery Connections at Header J2

A lithium battery with a nominal voltage of 3 V and a minimum capacity of 165 mA·h is recommended. A lithium battery is strongly recommended because of its nearly constant nominal voltage over most of its life.

The drain on the battery by the RCM3200 is typically 12 μA when no other power is supplied. If a 165 mA·h battery is used, the battery can last almost 2 years:

$$\frac{165 \text{ mA}\cdot\text{h}}{12 \text{ }\mu\text{A}} = 1.6 \text{ years.}$$

The actual life in your application will depend on the current drawn by components, not on the RCM3200 and the storage capacity of the battery. The RCM3200 does not drain the battery while it is powered up normally.

Cycle the main power off/on on the RCM3200 after you install a backup battery for the first time, and whenever you replace the battery. This step will minimize the current drawn by the real-time clock oscillator circuit from the backup battery should the RCM3200 experience a loss of main power.

NOTE: Remember to cycle the main power off/on any time the RCM3200 is removed from the Prototyping Board or motherboard since that is where the backup battery would be located.

Rabbit's Technical Note TN235, *External 32.768 kHz Oscillator Circuits*, provides additional information about the current draw by the the real-time clock oscillator circuit.

D.1.2 Battery-Backup Circuit

Figure D-2 shows the battery-backup circuit.

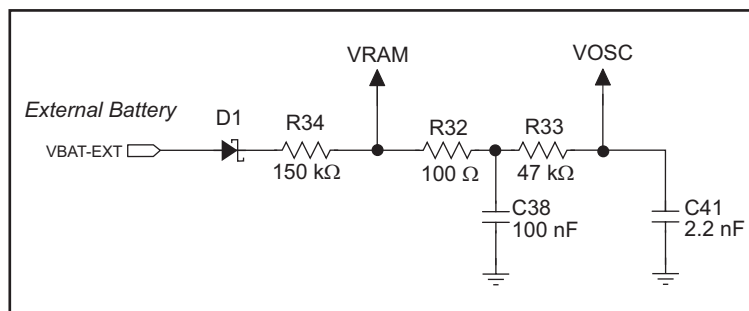

Figure D-2. RCM3200 Backup Battery Circuit

The battery-backup circuit serves three purposes:

- It reduces the battery voltage to the SRAM and to the real-time clock, thereby limiting the current consumed by the real-time clock and lengthening the battery life.
- It ensures that current can flow only *out* of the battery to prevent charging the battery.
- A voltage, VOSC, is supplied to U5, which keeps the 32.768 kHz oscillator working when the voltage begins to drop.

D.1.3 Reset Generator

The RCM3200 uses a reset generator to reset the Rabbit 3000 microprocessor when the voltage drops below the voltage necessary for reliable operation. The reset occurs between 2.85 V and 3.00 V, typically 2.93 V. The RCM3200 has a reset output, pin 1 on header J2.

D.2 Optional +5 V Output

The RCM3200 boards have an onboard charge pump that provides the +5 V needed by the RealTek Ethernet chip.



APPENDIX E. MOTOR CONTROL OPTION

The Prototyping Board has a header at J6 for a motor control option. While Rabbit does not support this option at this time, this appendix provides additional information about Parallel Port F on the Rabbit 3000 microprocessor to enable you to use this feature on the Prototyping Board for your needs.

E.1 Overview

The Parallel Port F connector on the Prototyping Board, J6, gives access to all 8 pins of Parallel Port F, along with +5 V. This appendix describes the function of each pin, and the ways they may be used for motion-control applications. It should be read in conjunction with the *Rabbit 3000 Microprocessor User's Manual* and the RCM3200 and the Prototyping Board schematics.

E.2 Header J6

The connector is a 2×5 , 0.1" pitch header suitable for connecting to an IDC header socket, with the following pin allocations.

Table E-1. Prototyping Board Header J6 Pinout

Pin	Rabbit 3000	Primary Function	Alternate Function 1	Alternate Function 2
1	Parallel Port F, bit 0	General-purpose I/O port	Quadrature decoder 1 Q input	SCLK_D
2	Parallel Port F, bit 1	General-purpose I/O port	Quadrature decoder 1 I input	SCLK_C
3	Parallel Port F, bit 2	General-purpose I/O port	Quadrature decoder 2 Q input	-
4	Parallel Port F, bit 3	General-purpose I/O port	Quadrature decoder 2 I input	-
5	Parallel Port F, bit 4	General-purpose I/O port	PWM[0] output	Quadrature decoder 1 Q input
6	Parallel Port F, bit 5	General-purpose I/O port	PWM[1] output	Quadrature decoder 1 I input
7	Parallel Port F, bit 6	General-purpose I/O port	PWM[2] output	Quadrature decoder 2 Q input
8	Parallel Port F, bit 7	General-purpose I/O port	PWM[3] output	Quadrature decoder 2 I input
9	+5 V	External buffer logic supply		
10	0 V	Common		

All Parallel Port F lines (pins 1 to 8) are pulled up internally to +3.3 V via 100 k Ω resistors. When used as outputs, the port pins will sink up to 6 mA at a V_{OL} of 0.4 V max. (0.2 V typ), and source up to 6 mA at a V_{OH} of 2.2 V typ. When used as inputs, all pins are 5 V tolerant.

As the outputs from Parallel Port F are compatible with 3.3 V logic, buffers may be needed when the external circuit drive requirements exceed the 2.2 V typ logic high and/or the 6 mA maximum from the Rabbit 3000. The +5 V supply output is provided for supplying interface logic. When used as inputs, the pins on header J6 do not require buffers unless the input voltage will exceed the 5 V tolerance of the processor pins. Usually, a simple resistive divider with catching diodes will suffice if higher voltage inputs are required. If the outputs are configured for open-drain operation, they may be pulled up to +5 V (while observing the maximum current, of course).

E.3 Using Parallel Port F

Parallel Port F is a byte-wide port with each bit programmable for data direction and drive. These are simple inputs and outputs controlled and reported in the Port F Data Register. As outputs, the bits of the port are buffered, with the data written to the Port F Data Register transferred to the output pins on a selected timing edge. The outputs of Timer A1, Timer B1, or Timer B2 can be used for this function, with each nibble of the port having a separate select field to control this timing. These inputs and outputs are also used for access to other peripherals on the chip.

As outputs, Parallel Port F can carry the four Pulse Width Modulator outputs on PF4–PF 7 (J6, pins 5–8). As inputs, Parallel Port F can carry the inputs to the Quadrature Decoders on PF0–PF3 (J6, pins 1–4). When Serial Port C or Serial Port D is used in clocked serial mode, two pins of Port F (PF0 / J6:1 and PF1 / J6:2) are used to carry the serial clock signals. When the internal clock is selected in these serial ports, the corresponding bit of Parallel Port F is set as an output.

E.3.1 Parallel Port F Registers

Data Direction Register—**PFDDR**, address 00111111 (0x3F), write-only, default value on reset 00000000. For each bit position, write a 1 to make the corresponding port line an output, or 0 to produce an input.

Drive Control Register—**PFDCR**, address 00111110 (0x3E), Write-only, no default on reset (port defaults to all inputs). Effective only if the corresponding port bits are set as outputs, each bit set to 1 configures the corresponding port bit as open drain. Setting the bit to 0 configures that output as active high or low.

Function Register—**PFFR**, address 00111101 (0x3D), Write-only, no default on reset. This register sets the alternate output function assigned to each of the pins of the port. When set to 0, the corresponding port pin functions normally as an output (if configured to be an output in **PFDDR**). When set to 1, each bit sets the corresponding pin to have the alternate output function as shown in the summary table at the end of this section.

Control Register—**PFCCR**, address 00111100 (0x3C), Write-only, default on reset xx00xx00. This register sets the transfer clock, which controls the timing of the outputs on each nibble of the output ports to allow close synchronization with other events. The summary table at the end of this section shows the settings for this register. The default values on reset transfer the output values on **CLK/2**.

Data Register—**PFDR**, address 00111000 (0x38), Read or Write, no default value on reset. On read, the current state of the pins is reported. On write, the output buffer is written with the value for transfer to the output port register on the next rising edge of the transfer clock, set in the **PFCCR**.

Table E-2. Parallel Port F Registers

Register Name	Mnemonic	I/O Address	R/W	Reset Value
Port F Data Register	PFDR	00111000 (0x38)	R/W	xxxxxxxx
Bits	Value	Description		
0:7	Read	Current state of pins		
	Write	Port buffer. Value transferred to O/P register on next rising edge of transfer clock.		
Port F Control Register	PFCR	00111100 (0x3C)	W only	xx00xx00
Bits	Value	Description		
0:1	00	Lower nibble transfer clock is CLK/2		
	01	Lower nibble transfer clock is Timer A1		
	10	Lower nibble transfer clock is Timer B1		
	11	Lower nibble transfer clock is Timer B2		
2:3	xx	These bits are ignored		
4:5	00	Upper nibble transfer clock is CLK/2		
	01	Upper nibble transfer clock is Timer A1		
	10	Upper nibble transfer clock is Timer B1		
	11	Upper nibble transfer clock is Timer B2		
6:7	xx	These bits are ignored		
Port F Function Register	PFFR	00111101 (0x3D)	W	xxxxxxxx
Bits	Value	Description		
0:7	0	Corresponding port bits function normally		
0	1	Bit 0 carries SCLK_D		
1	1	Bit 1 carries SCLK_C		
2:3	x	No effect		
4	1	Bit 4 carries PWM[0] output		
5	1	Bit 5 carries PWM[1] output		
6	1	Bit 6 carries PWM[2] output		
7	1	Bit 7 carries PWM[3] output		
Port F Drive Control Register	PFDCR	00111110 (0x3E)	W	xxxxxxxx
Bits	Value	Description		
0:7	0	Corresponding port bit is active high or low		
	1	Corresponding port bit is open drain		

Table E-2. Parallel Port F Registers (continued)

Register Name	Mnemonic	I/O Address	R/W	Reset Value
Port F Data Direction Register	PFDDR	00111111 (0x3F)	W	00000000
Bits	Value	Description		
0:7	0	Corresponding port bit is an input		
	1	Corresponding port bit is an output		

E.4 PWM Outputs

The Pulse-Width Modulator consists of a 10-bit free-running counter and four width registers. Each PWM output is high for $n + 1$ counts out of the 1024-clock count cycle, where n is the value held in the width register. The PWM output high time can optionally be spread throughout the cycle to reduce ripple on the externally filtered PWM output. The PWM is clocked by the output of Timer A9. The spreading function is implemented by dividing each 1024-clock cycle into four quadrants of 256 clocks each. Within each quadrant, the Pulse-Width Modulator uses the eight MSBs of each pulse-width register to select the base width in each of the quadrants. This is the equivalent to dividing the contents of the pulse-width register by four and using this value in each quadrant. To get the exact high time, the Pulse-Width Modulator uses the two LSBs of the pulse-width register to modify the high time in each quadrant according to Table E-3 below. The “ $n/4$ ” term is the base count, and is formed from the eight MSBs of the pulse-width register.

Table E-3. PWM Outputs

Pulse Width LSBs	1st	2nd	3rd	4th
00	$n/4 + 1$	$n/4$	$n/4$	$n/4$
01	$n/4 + 1$	$n/4$	$n/4 + 1$	$n/4$
10	$n/4 + 1$	$n/4 + 1$	$n/4 + 1$	$n/4$
11	$n/4 + 1$	$n/4 + 1$	$n/4 + 1$	$n/4 + 1$

The diagram below shows a PWM output for several different width values for both modes of operation. Operation in the spread mode reduces the filtering requirements on the PWM output in most cases.

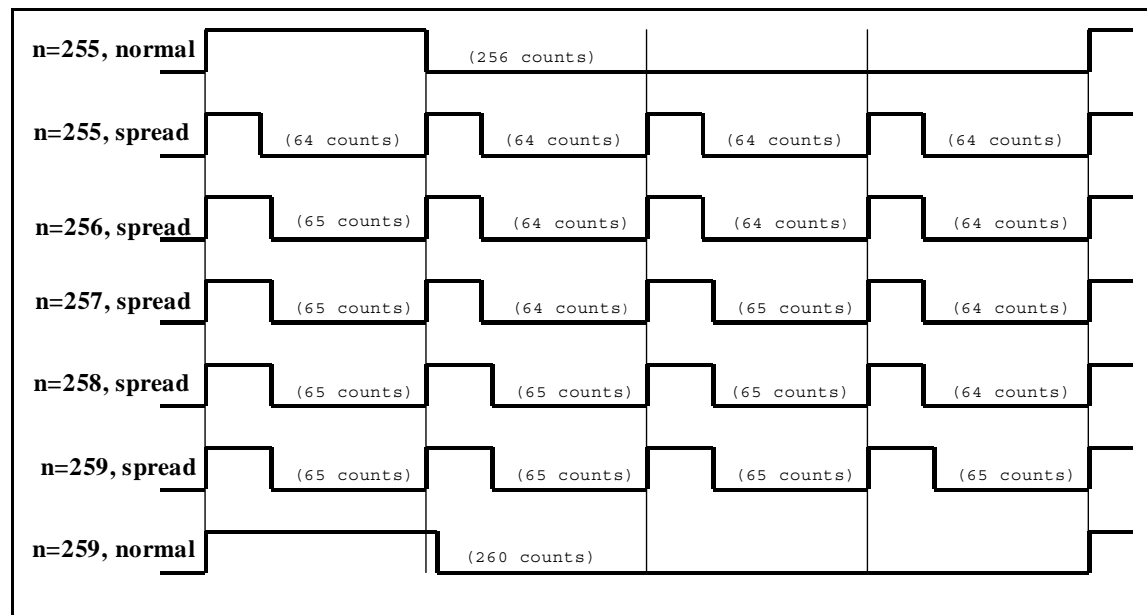

Figure E-1. PWM Outputs for Various Normal and Spread Modes

E.5 PWM Registers

There are no default values on reset for any of the PWM registers.

Table E-4. PWM Registers

PWM LSBs	Register	Address
	PWL0R	10001000 (0x88)
	PWL1R	10001010 (0x8A)
	PWL2R	10001100 (0x8C)
	PWL3R	10001110 (0x8E)
Bit(s)	Value	Description
7:6	Write	The least significant two bits for the Pulse Width Modulator count are stored
5:1		These bits are ignored.
0	0	PWM output High for single block.
	1	Spread PWM output throughout the cycle
PWM MSB x	Register	Address
	PWM0R	Address = 10001001 (0x89)
	PWM1R	Address = 10001011 (0x8B)
	PWM2R	Address = 10001101 (0x8D)
	PWM3R	Address = 10001111 (0x8F)
Bit(s)	Value	Description
7:0	write	The most significant eight bits for the Pulse-Width Modulator count are stored With a count of n , the PWM output will be high for $n + 1$ clocks out of the 1024 clocks of the PWM counter.

E.6 Quadrature Decoder

The two-channel Quadrature Decoder accepts inputs via Parallel Port F from two external optical incremental encoder modules. Each channel of the Quadrature Decoder accepts an in-phase (I) and a quadrature-phase (Q) signal, and provides 8-bit counters to track shaft rotation and provide interrupts when the count goes through the zero count in either direction. The Quadrature Decoder contains digital filters on the inputs to prevent false counts and is clocked by the output of Timer A10. Each Quadrature Decoder channel accepts inputs from either the upper nibble or lower nibble of Parallel Port F. The I signal is input on an odd-numbered port bit, while the Q signal is input on an even-numbered port bit. There is also a disable selection, which is guaranteed not to generate a count increment or decrement on either entering or exiting the disable state. The operation of the counter as a function of the I and Q inputs is shown below.

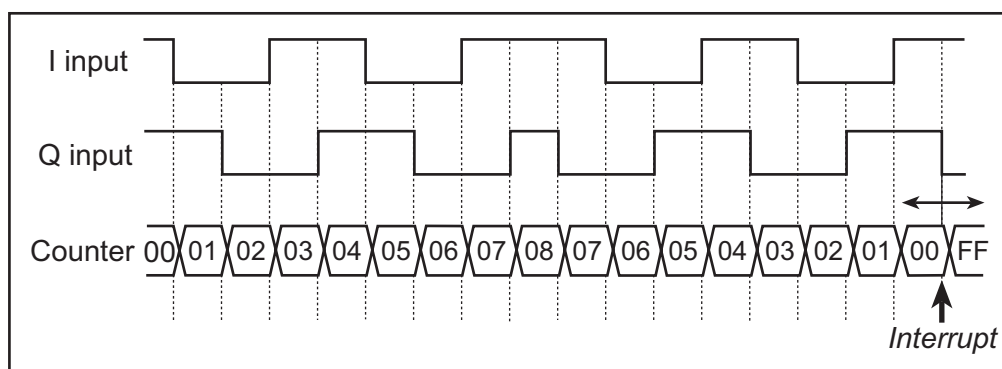
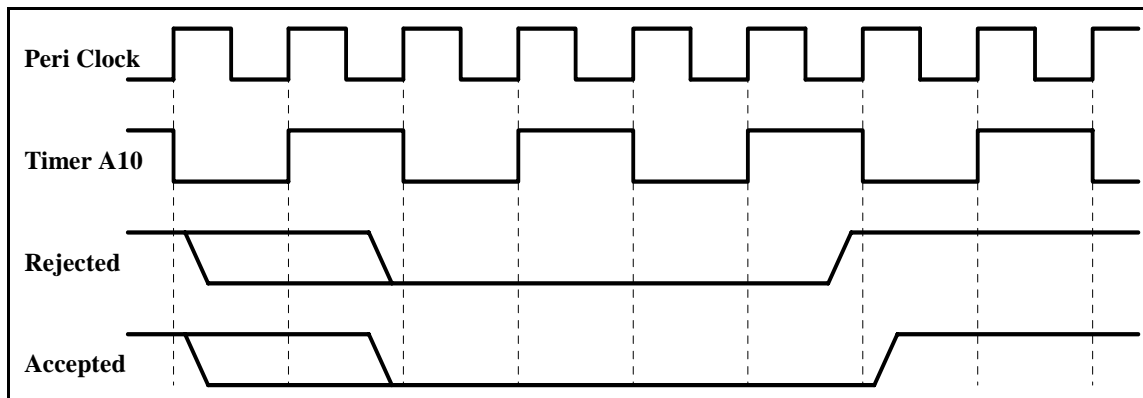

Figure E-2. Operation of Quadrature Decoder Counter

The Quadrature Decoders are clocked by the output of Timer A10, giving a maximum clock rate of one-half of the peripheral clock rate. The time constant of Timer A10 must be fast enough to sample the inputs properly. Both the I and Q inputs go through a digital filter that rejects pulses shorter than two clock periods wide. In addition, the clock rate must be high enough that transitions on the I and Q inputs are sampled in different clock cycles. The Input Capture (see the *Rabbit 3000 Microprocessor Users Manual*) may be used to measure the pulse width on the I inputs because they come from the odd-numbered port bits. The operation of the digital filter is shown below.



The Quadrature Decoder generates an interrupt when the counter increments from 0x00 to 0x01 or when the counter decrements from 0x00 to 0xFF. Note that the status bits in the QDCSR are set coincident with the interrupt, and the interrupt (and status bits) are cleared by reading the QDCSR.

Table E-5. Quadrature Decoder Registers

Register Name	Mnemonic	Address
Quad Decode Control/Status Register	QDCSR	10010000 (0x90)
Bit	Value	Description
7 (rd-only)	0	Quadrature Decoder 2 did not increment from 0xFF.
	1	Quadrature Decoder 2 incremented from 0xFF to 0x00. This bit is cleared by a read of this register.
6 (rd-only)	0	Quadrature Decoder 2 did not decrement from 0x00.
	1	Quadrature Decoder 2 decremented from 0x00 to 0xFF. This bit is cleared by a read of this register.
5	0	This bit always reads as zero.
4 (wr-only)	0	No effect on the Quadrature Decoder 2.
	1	Reset Quadrature Decoder 2 to 0x00, without causing an interrupt.
3 (rd-only)	0	Quadrature Decoder 1 did not increment from 0xFF.
	1	Quadrature Decoder 1 incremented from 0xFF to 0x00. This bit is cleared by a read of this register.
2 (rd-only)	0	Quadrature Decoder 1 did not decrement from 0x00.
	1	Quadrature Decoder 1 decremented from 0x00 to 0xFF. This bit is cleared by a read of this register.
1	0	This bit always reads as zero.
Bit	Value	Description
0 (wr-only)	0	No effect on the Quadrature Decoder 1.
	1	Reset Quadrature Decoder 1 to 0x00, without causing an interrupt.

Table E-5. Quadrature Decoder Registers (continued)

Register Name	Mnemonic	Address
Quad Decode Control Register	QDCR	Address = 10010001 (0x91)
Bit	Value	Description
7:6	0x	Disable Quadrature Decoder 2 inputs. Writing a new value to these bits will not cause Quadrature Decoder 2 to increment or decrement.
	10	Quadrature Decoder 2 inputs from Port F bits 3 and 2.
	11	Quadrature Decoder 2 inputs from Port F bits 7 and 6.
5:4	xx	These bits are ignored.
3:2	0x	Disable Quadrature Decoder 1 inputs. Writing a new value to these bits will not cause Quadrature Decoder 1 to increment or decrement.
	10	Quadrature Decoder 1 inputs from Port F bits 1 and 0.
	11	Quadrature Decoder 1 inputs from Port F bits 5 and 4.
1:0	0	Quadrature Decoder interrupts are disabled.
	1	Quadrature Decoder interrupt use Interrupt Priority 1.
	10	Quadrature Decoder interrupt use Interrupt Priority 2.
	11	Quadrature Decoder interrupt use Interrupt Priority 3.
Quad Decode Count Register	QDC1R	Address = 10010100 (0x94)
	(QDC2R)	Address = 10010110 (0x96)
Bit(s)	Value	Description
7:0	read	The current value of the Quadrature Decoder counter is reported.

INDEX

- A**
 - additional information
 - online documentation 7
- B**
 - battery backup
 - battery life 114
 - circuit 114
 - external battery connections 113
 - real-time clock 114
 - reset generator 115
 - use of battery-backed SRAM 39
 - board initialization
 - function calls 41
 - brdInit 41
 - bus loading 63
- C**
 - clock doubler 35
 - conformal coating 68
 - connectivity interface kits
 - Connector Adapter Board ... 7
 - Connector Adapter Board 7
- D**
 - Development Kit 9
 - AC adapter 6
 - DC power supply 6
 - programming cable 6
 - RCM3200 6
 - Getting Started instructions 6
 - digital I/O 24
 - I/O buffer sourcing and sinking limits 67
 - memory interface 29
 - SMODE0 29, 32
 - SMODE1 29, 32
- E**
 - dimensions
 - LCD/keypad module 83
 - LCD/keypad template 86
 - Prototyping Board 75
 - RCM3200 58
 - Dynamic C 7, 9, 16, 37
 - add-on modules 9, 42
 - installation 9
 - battery-backed SRAM 39
 - protected variables 39
 - Rabbit Embedded Security Pack 7, 9, 42
 - sample programs 20
 - standard features
 - debugging 38
 - telephone-based technical support 7, 42
 - upgrades and patches 42
 - USB port settings 16
- F**
 - features
 - comparison with RCM3209/RCM3229 4
 - Prototyping Board 72, 73
- H**
 - hardware connections 10
 - install RCM3200 on Prototyping Board 11
 - power supply 14
 - programming cable 12
 - hardware reset 14
- I**
 - I/O address assignments
 - LCD/keypad module 87
 - I/O buffer sourcing and sinking limits 67
 - IP addresses 47
 - how to set in sample programs 52
 - how to set PC IP address .. 53
- J**
 - jumper configurations
 - RCM3200 69
 - JP2 (program execution SRAM size) 69
 - JP3 (flash memory size) 69
 - JP4 (flash memory bank select) 36, 69
 - JP5 (data SRAM size) ... 69
 - jumper locations 69
- K**
 - keypad template 86
 - removing and inserting label 86

L

LCD/keypad module

bezel-mount installation	89
dimensions	83
function calls	
dispInit	92
header pinout	87
I/O address assignments	87
keypad	
function calls	
keyConfig	108
keyGet	109
keyInit	108
keypadDef	110
keyProcess	109
keyScan	110
keyUnget	109
keypad template	86
LCD display	
function calls	
glBackLight	93
glBlankScreen	94
glBlock	94
glBuffLock	100
glBuffUnlock	100
glDispOnOff	93
glDown1	103
glFillCircle	97
glFillPolygon	96
glFillScreen	94
glFillVPolygon	96
glFontCharAddr	97
glGetBrushType	101
glGetPfStep	98
glHScroll	103
glInit	93
glLeft1	102
glPlotCircle	96
glPlotDot	101
glPlotLine	101
glPlotPolygon	95
glPlotVPolygon	95
glPrintf	99
glPutChar	99
glPutFont	98
glRight1	102
glSetBrushType	100
glSetContrast	94
glSetPfStep	98
glSwap	100
glUp1	102
glVScroll	104
glXFontInit	97
glXPutBitmap	104

glXPutFastmap	105
TextCursorLocation	106
TextGotoXY	106
TextPrintf	107
TextPutChar	106
TextWindowFrame	105

LEDs

function calls	92
ledOut	92
mounting instructions	88
remote cable connection	91
removing and inserting keypad	
label	86
sample programs	111
voltage settings	85

M

MAC addresses	48
motor control applications	79
motor control option	
quadrature decoder	124
mounting instructions	
LCD/keypad module	88

P

physical mounting	62
pinout	
Ethernet port	31
LCD/keypad module	87
Prototyping Board	77
RCM3200	
alternate configurations	26
RCM3200 headers	24
power supplies	
+3.3 V	113
battery backup	113
optional +5 V output	115
power supply	
connections	14
Program Mode	33
switching modes	33
programming cable	117
PROG connector	33
RCM3200 connections	12
programming port	32
Prototyping Board	72
adding RS-232 transceiver	78
dimensions	75
expansion area	73
features	72, 73
J6	
pinout	118
motor encoder connector	
pinout	79

mounting RCM3200	11
pinout	77
power supply	76
prototyping area	77
specifications	76
use of parallel ports	80
PWM outputs	122
PWM registers	123

Q

quadrature decoder	124
quadrature decoder registers	125

R

Rabbit 3000	
data and clock delays	65
Parallel Port F Registers	119
Parallel Port F registers	120
PWM outputs	122
PWM registers	123
quadrature decoder registers	125
spectrum spreader time delays	65
Rabbit subsystems	25
RCM3200	
comparison with	
RCM3209/RCM3229	4
mounting on Prototyping	
Board	11
real-time clock	
battery backup	114
reset	14
Run Mode	33
switching modes	33

S

sample programs	20
getting to know the RCM3200	
CONTROLLED.C	20
FLASHLED1.C	20
FLASHLED2.C	20
IR_DEMO.C	20
TOGGLESWITCH.C	20
how to run TCP/IP sample	
programs	51, 52
how to set IP address	52
LCD/keypad	
KEYPADTOLED.C	111
LCDKEYFUN.C	111
SWITCHTOLED.C	111
LCD/keypad module	111
PONG.C	16



SCHEMATICS

090-0152 RCM3200 Schematic

www.rabbit.com/documentation/schemat/090-0152.pdf

090-0137 Prototyping Board Schematic

www.rabbit.com/documentation/schemat/090-0137.pdf

090-0156 LCD/Keypad Module Schematic

www.rabbit.com/documentation/schemat/090-0156.pdf

090-0128 Programming Cable Schematic

www.rabbit.com/documentation/schemat/090-0128.pdf

You may use the URL information provided above to access the latest schematics directly.

Mouser Electronics

Authorized Distributor

Click to View Pricing, Inventory, Delivery & Lifecycle Information:

[Rabbit Semiconductor:](#)

[20-101-0542](#)