

4

3

2

1

THIS DRAWING IS UNPUBLISHED. RELEASED FOR PUBLICATION
© COPYRIGHT ALL RIGHTS RESERVED.

LOC	DIST	REVISIONS			
P	LTR	DESCRIPTION	DATE	DWN	APVD
	A1	ECR-14-003919	18MAR2014	GK	HMR

REPLACED BY OCEAN STYLE APPLICATOR PART NUMBER 2266162-1

FOR REPLACEMENT PARTS FOR APPLICATOR 1385863 REFER TO ADDITIONAL PAGE(S). SPARE PARTS KIT (IF LISTED) WILL REMAIN AVAILABLE.

THE REPLACEMENT OCEAN STYLE APPLICATOR HAS THE SAME TERMINATOR/PRESS INTERFACE AS APPLICATOR 1385863

THIS DRAWING IS A CONTROLLED DOCUMENT.		DWN	GOPALAKRISHNA HV														
DIMENSIONS:		CHK	RAGHAVENDRA														
TOLERANCES UNLESS OTHERWISE SPECIFIED:		APVD	RAGHAVENDRA														
<table border="0"> <tr><td>0 PLC</td><td>±</td></tr> <tr><td>1 PLC</td><td>±</td></tr> <tr><td>2 PLC</td><td>±</td></tr> <tr><td>3 PLC</td><td>±</td></tr> <tr><td>4 PLC</td><td>±</td></tr> <tr><td>ANGLES</td><td>±</td></tr> </table>		0 PLC	±	1 PLC	±	2 PLC	±	3 PLC	±	4 PLC	±	ANGLES	±	NAME	SIDE FEED HDM APPLICATOR		
0 PLC	±																
1 PLC	±																
2 PLC	±																
3 PLC	±																
4 PLC	±																
ANGLES	±																
MATERIAL		PRODUCT SPEC															
FINISH		APPLICATION SPEC															
		WEIGHT	SIZE	CAGE CODE	DRAWING NO												
			A3		©- 1385863												
		CUSTOMER DRAWING	SCALE	SHEET 1 OF 3	REV A1												

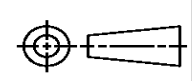

THIS DRAWING IS A CONTROLLED DOCUMENT

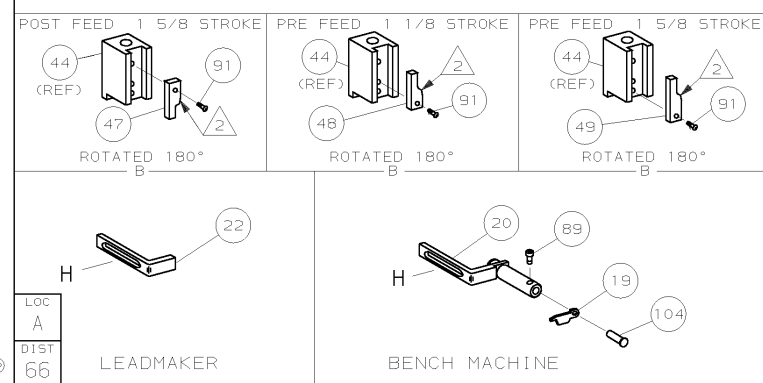
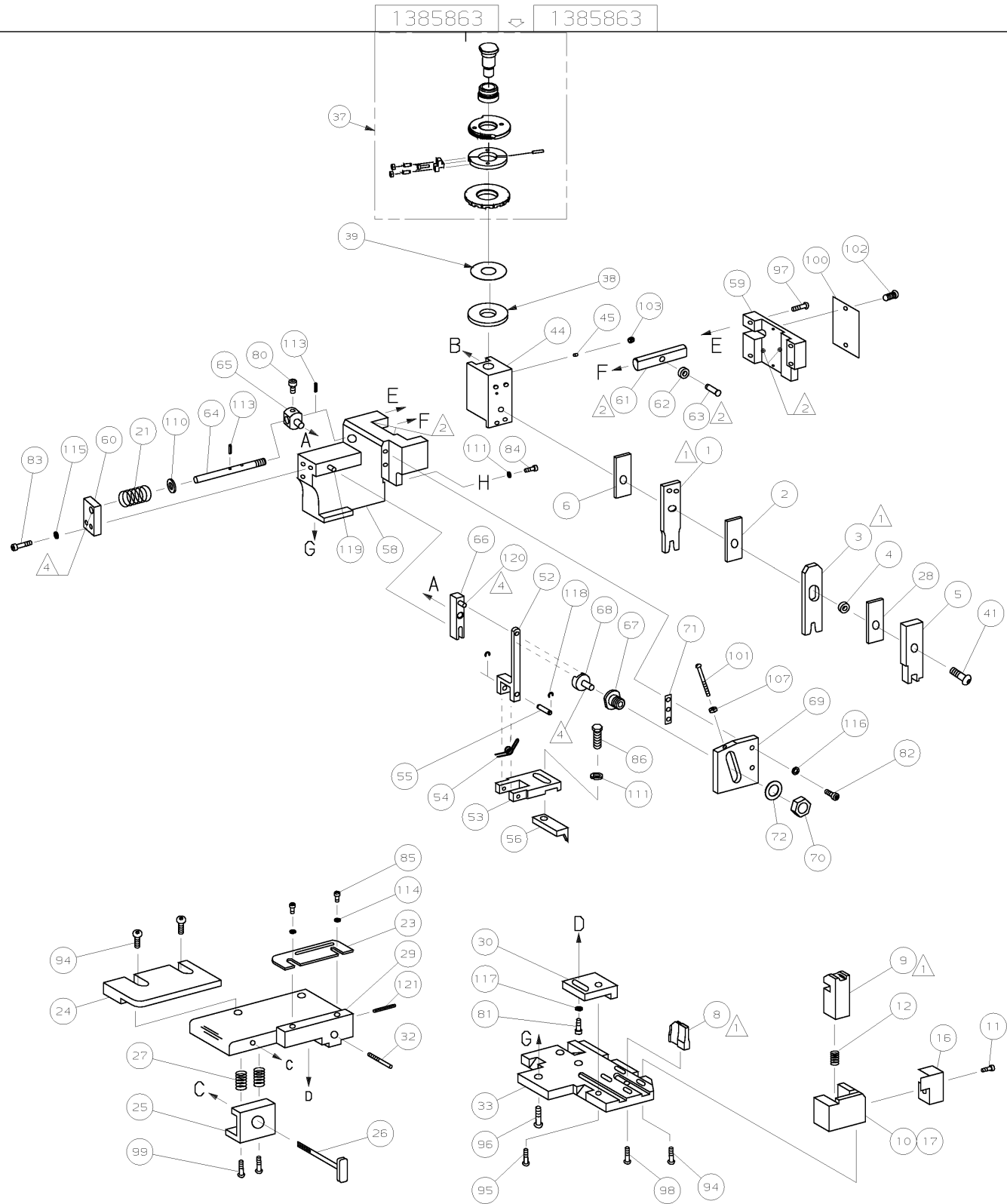

LOC A
DIST 66

LEADMAKER

BENCH MACHINE

RELEASD FOR PUBLICATION JANUARY 14, 2005
ALL RIGHTS RESERVED.
COPYRIGHT 2005

DWG SIZE	PART NO	DESCRIPTION	ITEM NO
← REVISION OF EACH ASSY NO (WHEN BLANK, USE DWG REVISION)			
QTY REQD PER ASSY			
PARTS LIST			
MATL	HT TR	FIN	
DR	APP		
CHK	REL		
NAME SIDE FEED HDM APPLICATOR		MACHINE REF	
SCALE	DWG NO	1385863	SHEET 2 of 2 REV A
CASE CODE 00779	CUSTOMER AND ASSEMBLY DRAWING		RESTRICTED TO

SEE SHEET 1					
P	F	L	T	R	
REVISION RECORD			APP	DATE	

Mouser Electronics

Authorized Distributor

Click to View Pricing, Inventory, Delivery & Lifecycle Information:

[TE Connectivity:](#)

[9-1385863-3](#)