

## HIP6521

### PWM and Triple Linear Power Controller

FN4837  
 Rev.5.00  
 Oct 16, 2006

The HIP6521 provides the power control and protection for four output voltages in high-performance microprocessor and computer applications. The IC integrates a voltage-mode PWM controller and three linear controllers, as well as monitoring and protection functions into a 16 Ld SOIC package. The PWM controller is intended to regulate the microprocessor memory core voltage with a synchronous-rectified buck converter. The linear controllers are intended to regulate the computer system's AGP 1.5V bus power, the 2.5V clock power, and the 1.8V power for the North/South Bridge core voltage and/or cache memory circuits. Both the switching regulator and linear voltage references provide  $\pm 2\%$  of static regulation over line, load, and temperature ranges. All outputs are user-adjustable by means of an external resistor divider. All linear controllers employ bipolar NPNs for the pass transistors.

The HIP6521 monitors all the output voltages. The PWM controller's adjustable overcurrent function monitors the output current by using the voltage drop across the upper MOSFET's  $r_{DS(ON)}$ . The linear regulator outputs are monitored via the FB pins for undervoltage events.

### Ordering Information

PART NUMBER	PART MARKING	TEMP. RANGE (°C)	PACKAGE	PKG. DWG. #
HIP6521CB	HIP6521CB	0 to 70	16 Ld SOIC	M16.15
HIP6521CBZ (Note)	6521CBZ	0 to 70	16 Ld SOIC (Pb-free)	M16.15
HIP6521EVAL1	Evaluation Board			

NOTE: Intersil Pb-free plus anneal products employ special Pb-free material sets; molding compounds/die attach materials and 100% matte tin plate termination finish, which are RoHS compliant and compatible with both SnPb and Pb-free soldering operations. Intersil Pb-free products are MSL classified at Pb-free peak reflow temperatures that meet or exceed the Pb-free requirements of IPC/JEDEC J STD-02.

Add "-T" suffix for tape and reel.

### Features

- Provides 4 Regulated Voltages
  - Memory Core, AGP, Clock, and Memory Controller Hub Power
- ACPI Compatible
- Drives Bipolar Linear Pass Transistors
- Externally Resistor-Adjustable Outputs
- Simple Single-Loop Control Design
  - Voltage-Mode PWM Control
- Fast PWM Converter Transient Response
  - High-Bandwidth Error Amplifier
  - Full 0% to 100% Duty Ratio
- Excellent Output Voltage Regulation
  - All Outputs:  $\pm 2\%$  Over Temperature
- Overcurrent Fault Monitors
  - Switching Regulator Does Not Require Extra Current Sensing Element, Uses MOSFET's  $r_{DS(ON)}$
- Small Converter Size
  - 300kHz Constant Frequency Operation
  - Small External Component Count
- Pb-Free Plus Anneal Available (RoHS Compliant)

### Applications

- Motherboard Power Regulation for Computers

### Related Literature

- Technical Brief TB363 "Guidelines for Handling and Processing Moisture Sensitive Surface Mount Devices (SMDs)"

### Pinout

HIP6521 (SOIC)  
TOP VIEW

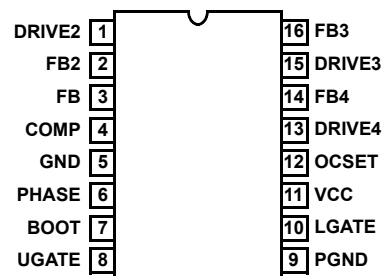

### Block Diagram

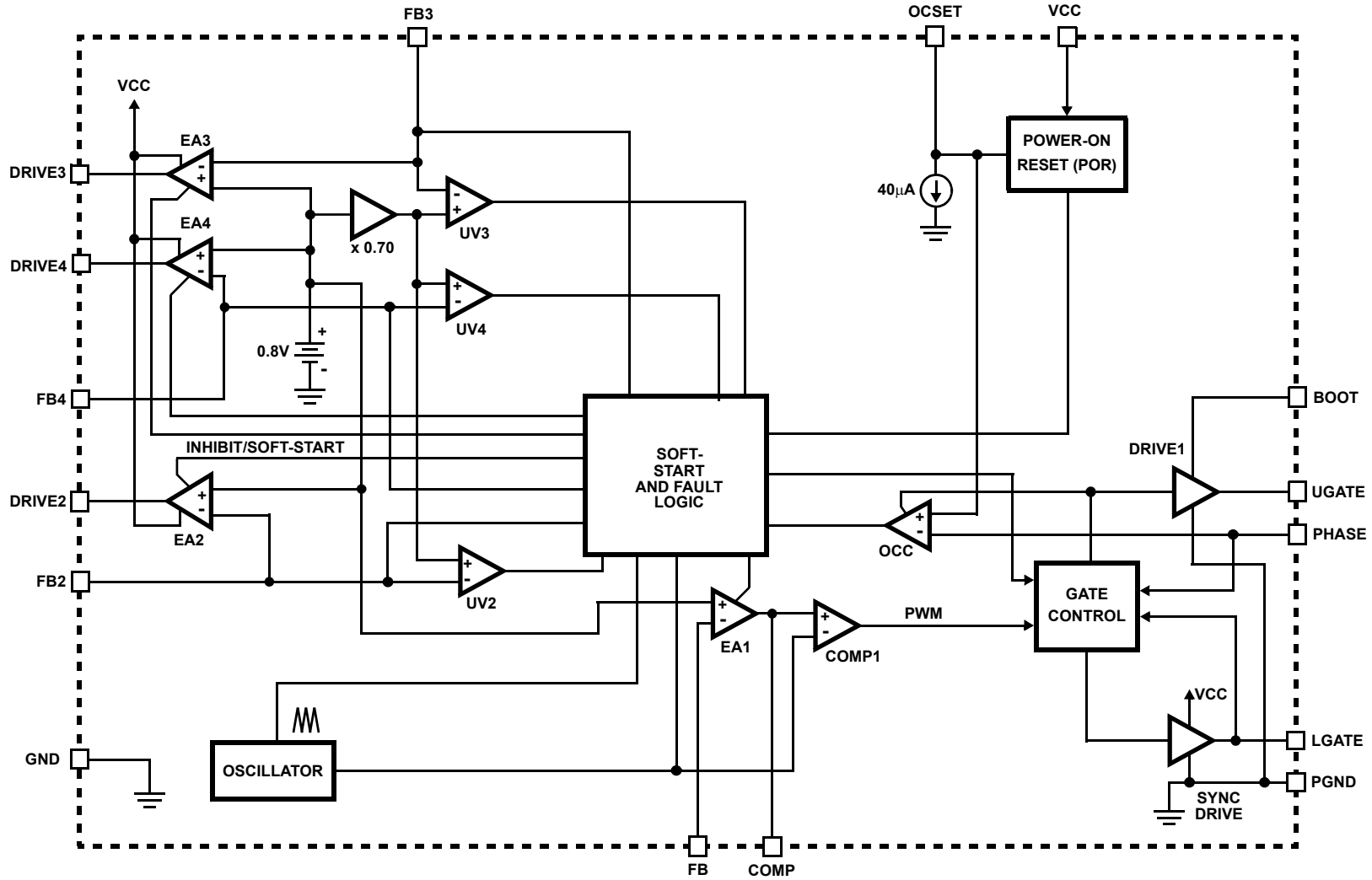

**Simplified Power System Diagram**

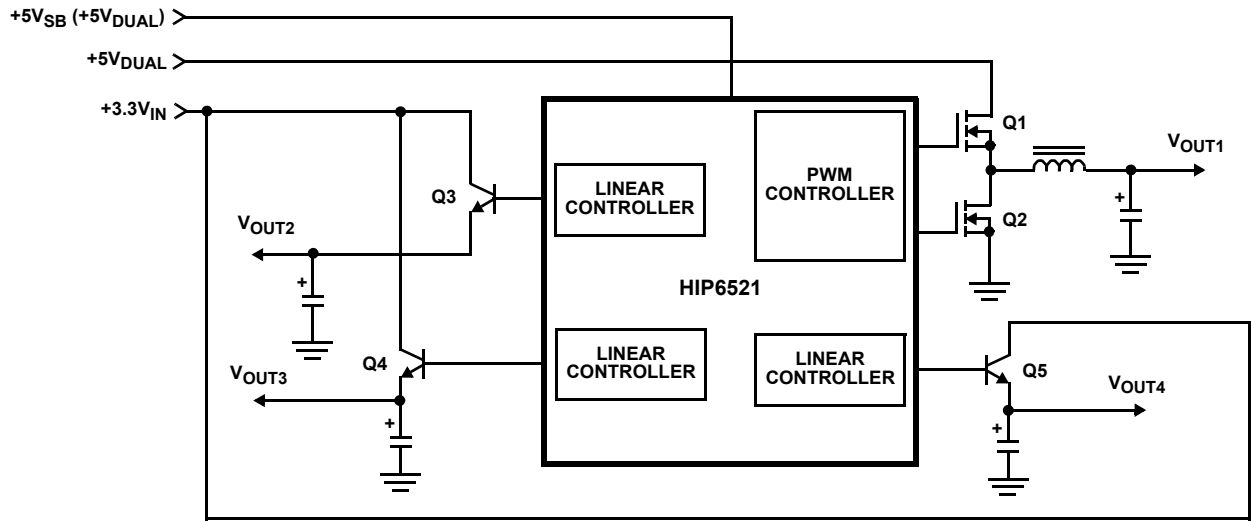

**Typical Application**

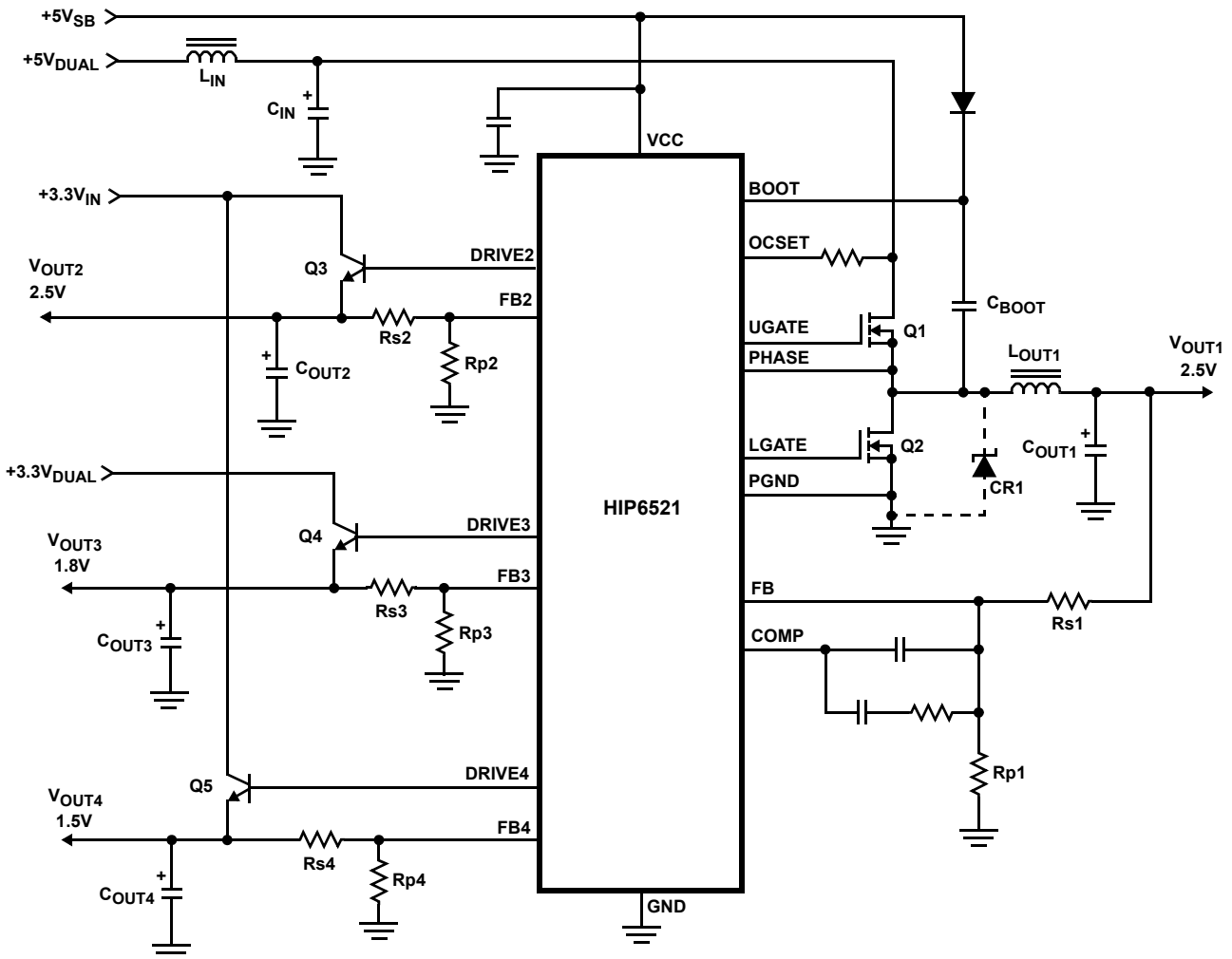

**Absolute Maximum Ratings**

UGATE, BOOT	GND - 0.3V to 15V
VCC, PHASE	GND - 0.3V to +7V
DRIVE, LGATE, All Other Pins	GND - 0.3V to VCC + 0.3V
ESD Classification	TBD

**Operating Conditions**

Supply Voltage on VCC	+5V ±10%
Ambient Temperature Range	0°C to 70°C
Junction Temperature Range	0°C to 125°C

CAUTION: Stresses above those listed in "Absolute Maximum Ratings" may cause permanent damage to the device. This is a stress only rating and operation of the device at these or any other conditions above those indicated in the operational sections of this specification is not implied.

## NOTE:

1.  $\theta_{JA}$  is measured with the component mounted on a low effective thermal conductivity test board in free air. See Tech Brief TB379 for details.

**Thermal Information**

Thermal Resistance (Typical, Note 1)	$\theta_{JA}$ (°C/W)
SOIC Package	110
Maximum Junction Temperature (Plastic Package)	150°C
Maximum Storage Temperature Range	-65°C to 150°C
Maximum Lead Temperature (Soldering 10s)	300°C (SOIC - Lead Tips Only)

**Electrical Specifications** Recommended Operating Conditions, Unless Otherwise Noted. Refer to Block and Simplified Power System Diagrams, and Typical Application Schematic

PARAMETER	SYMBOL	TEST CONDITIONS	MIN	TYP	MAX	UNITS
<b>VCC SUPPLY CURRENT</b>						
Nominal Supply Current	$I_{CC}$	UGATE, LGATE, DRIVE2, DRIVE3, and DRIVE4 Open	-	5	-	mA
<b>POWER-ON RESET</b>						
Rising VCC Threshold			4.25	-	4.5	V
Falling VCC Threshold			3.75	-	4.0	V
<b>OSCILLATOR AND SOFT-START</b>						
Free Running Frequency	$F_{OSC}$		275	300	325	kHz
Ramp Amplitude	$\Delta V_{OSC}$		-	1.5	-	$V_{P-P}$
Soft-Start Interval	$T_{SS}$		6.25	6.83	7.40	ms
<b>REFERENCE VOLTAGE</b>						
Reference Voltage (All Regulators)	$V_{REF}$		-	0.800	-	V
All Outputs Voltage Regulation			-2.0	-	+2.0	%
<b>LINEAR REGULATORS (OUT2, OUT3, AND OUT4)</b>						
Output Drive Current (All Linears)		VCC > 4.5V	100	120	-	mA
Undervoltage Level ( $V_{FB}/V_{REF}$ )	$V_{UV}$		-	70	-	%
<b>SYNCHRONOUS PWM CONTROLLER ERROR AMPLIFIER</b>						
DC Gain			-	80	-	dB
Gain-Bandwidth Product	GBWP		15	-	-	MHz
Slew Rate	SR	COMP = 10pF	-	6	-	V/ $\mu$ s
<b>PWM CONTROLLER GATE DRIVERS</b>						
UGATE Source	$I_{UGATE}$	VCC = 5V, $V_{UGATE} = 2.5V$	-	-1	-	A
UGATE Sink	$I_{UGATE}$	$V_{UGATE-PHASE} = 2.5V$	-	1	-	A
LGATE Source	$I_{LGATE}$	VCC = 5V, $V_{LGATE} = 2.5V$	-	-1	-	A
LGATE Sink	$I_{LGATE}$	$V_{LGATE} = 2.5V$	-	2	-	A
<b>PROTECTION</b>						
OCSET Current Source	$I_{OCSET}$		34	40	46	$\mu$ A

## Functional Pin Descriptions

### VCC (Pin 11)

Provide a well decoupled 5V bias supply for the IC to this pin. This pin also provides the gate bias charge for the lower MOSFET controlled by the PWM section of the IC, as well as the base current drive for the linear regulators' external bipolar transistors. The voltage at this pin is monitored for Power-On Reset (POR) purposes.

### GND (Pin 5)

Signal ground for the IC. All voltage levels are measured with respect to this pin.

### PGND (Pin 9)

This is the power ground connection. Tie the synchronous PWM converter's lower MOSFET source to this pin.

### BOOT (Pin 7)

Connect a suitable capacitor (0.47 $\mu$ F recommended) from this pin to PHASE. This bootstrap capacitor supplies UGATE driver the energy necessary to turn and hold the upper MOSFET on.

### OCSET (Pin 12)

Connect a resistor from this pin to the drain of the upper PWM MOSFET. This resistor, an internal 40 $\mu$ A current source (typical), and the upper MOSFET's on-resistance set the converter overcurrent trip point. An overcurrent trip cycles the soft-start function.

The voltage at this pin is monitored for power-on reset (POR) purposes and pulling this pin below 1.25V with an open drain/collector device will shutdown the switching controller.

### PHASE (Pin 6)

Connect the PHASE pin to the PWM converter's upper MOSFET source. This pin is used to monitor the voltage drop across the upper MOSFET for overcurrent protection.

### UGATE (Pin 8)

Connect UGATE pin to the PWM converter's upper MOSFET gate. This pin provides the gate drive for the upper MOSFET.

### LGATE (Pin 10)

Connect LGATE to the PWM converter's lower MOSFET gate. This pin provides the gate drive for the lower MOSFET.

### COMP and FB (Pins 4, 3)

COMP and FB are the available external pins of the PWM converter error amplifier. The FB pin is the inverting input of the error amplifier. Similarly, the COMP pin is the error amplifier output. These pins are used to compensate the voltage-mode control feedback loop of the synchronous PWM converter.

### DRIVE2, 3, 4 (Pins 1, 15, 13)

Connect these pins to the base terminals of external bipolar NPN transistors. These pins provide the base current drive for the regulator pass transistors.

### FB2, 3, 4 (Pins 2, 16, 14)

Connect the output of the corresponding linear regulators to these pins through properly sized resistor dividers. The voltage at these pins is regulated to 0.8V. These pins are also monitored for undervoltage events.

Quickly pulling and holding any of these pins above 1.25V (using diode-coupled logic devices) shuts off the respective regulators. Releasing these pins from the pull-up voltage initiates a soft-start sequence on the respective regulator.

## Description

### Operation

The HIP6521 monitors and precisely controls 4 output voltage levels (Refer to Block and Simplified Power System Diagrams, and Typical Application Schematic). It is designed for microprocessor computer applications with 3.3V, and 5V (5V<sub>DUAL</sub>) bias input from an ATX power supply. The IC has a synchronous PWM controller and three linear controllers. The PWM controller (PWM) is designed to regulate the 2.5V memory voltage (V<sub>OUT1</sub>). The PWM controller drives 2 MOSFETs (Q1 and Q2) in a synchronous-rectified buck converter configuration and regulates the output voltage to a level programmed by a resistor divider. The linear controllers are designed to regulate three more of the computer system's voltages, typically the 1.5V AGP bus (V<sub>OUT4</sub>), the 2.5V clock voltage (V<sub>OUT2</sub>), and the 1.8V ICH/MCH core voltage (V<sub>OUT3</sub>). All linear controllers are designed to employ external NPN bipolar pass transistors.

### Initialization

The HIP6521 automatically initializes upon receipt of input power. Special sequencing of the input supplies is not necessary. The Power-On Reset (POR) function continually monitors the input bias supply voltage. The POR monitors the bias voltage at the VCC pin. The POR function initiates soft-start operation after the bias supply voltage exceeds its POR threshold.

### Soft-Start

The POR function initiates the soft-start sequence. The PWM error amplifier reference input is clamped to a level proportional to the soft-start voltage. As the soft-start voltage slews up, the PWM comparator generates PHASE pulses of increasing width that charge the output capacitor(s). Similarly, all linear regulators' reference inputs are clamped to a voltage proportional to the soft-start voltage. The ramp-up of the internal soft-start function provides a controlled output voltage rise.

Figure 1 shows the soft-start sequence for the typical application. At T<sub>0</sub> the +5V<sub>SB</sub> bias voltage starts to ramp up (closely followed by the +5V<sub>DUAL</sub> voltage) crossing the 4.5V POR threshold at time T<sub>1</sub>. On the PWM section, the oscillator's triangular waveform is compared to the clamped error amplifier

output voltage. As the internal soft-start voltage increases, the pulse-width on the PHASE pin increases to reach its steady-state duty cycle at time T2. At time T3, the 3.3V input supply starts ramping up; as a result, V<sub>OUT2</sub> and V<sub>OUT4</sub> start ramping up on the second attempt (approximately 3.25 SS cycles wait), at time T4. During the interval between T4 and T5, the linear controller error amplifiers' references ramp to the final value bringing all outputs within regulation limits.

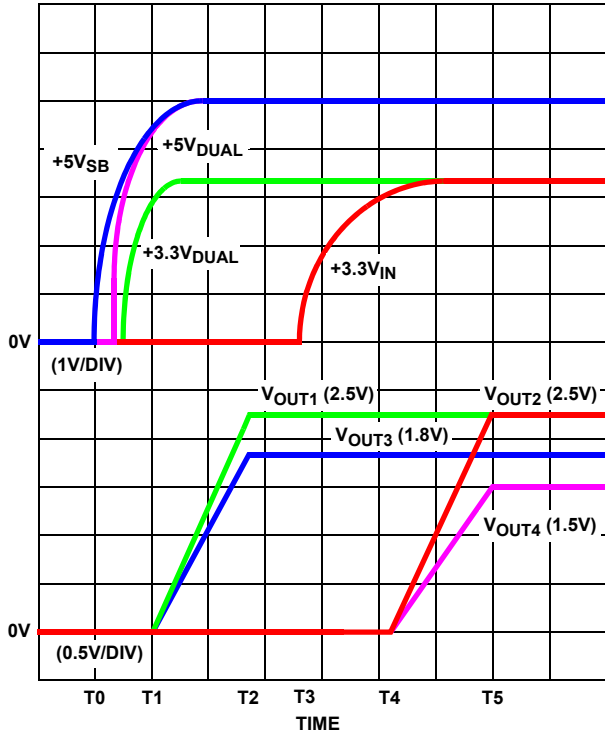

FIGURE 1. SOFT-START INTERVAL

**Overcurrent Protection**

All outputs are protected against excessive overcurrents. The PWM controller uses the upper MOSFET's on-resistance, r<sub>DS(ON)</sub> to monitor the current for protection against shorted output. All linear controllers monitor their respective FB pins for undervoltage events to protect against excessive currents.

A sustained overload (undervoltage on linears or overcurrent on the PWM) on any output results in an independent shutdown of the respective output, followed by subsequent individual re-start attempts performed at an interval equivalent to 3 soft-start intervals. Figure 2 describes the protection feature. At time T0, an overcurrent event sensed across the switching regulator's upper MOSFET (r<sub>DS(ON)</sub> sensing) triggers a shutdown of the V<sub>OUT1</sub> output. As a result, its internal soft-start initiates a number of soft-start cycles. After a three-cycle wait, the fourth soft-start initiates a ramp-up attempt of the failed output, at time T2, bringing the output in regulation at time T4.

To exemplify an UV event on one of the linears, at time T1, the clock regulator (V<sub>OUT2</sub>) is also subjected to an

overcurrent event, resulting in an UV condition. Similarly, after three soft-start periods, the fourth cycle initiates a ramp-up of this linear output at time T3. One soft-start period after T3, the linear output is within regulation limits. UV glitches less than 1μs (typically) in duration are ignored.

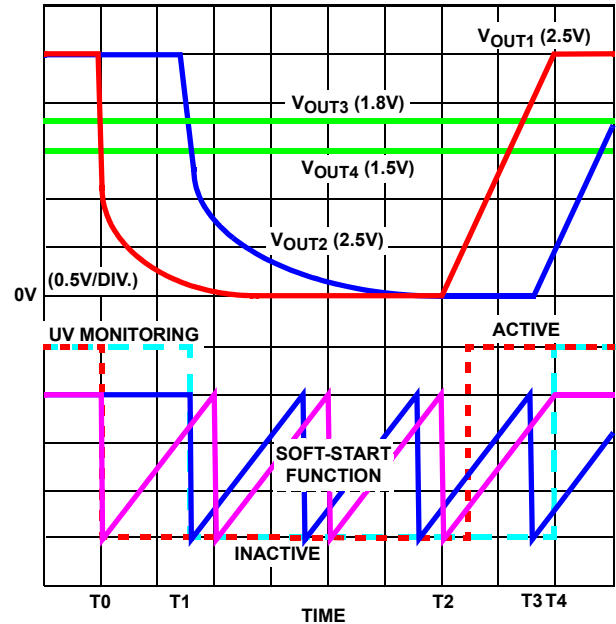

FIGURE 2. OVERCURRENT/UNDERVOLTAGE PROTECTION RESPONSE

As overcurrent protection is performed on the synchronous switcher regulator on a cycle-by-cycle basis, OC monitoring is active as long as the regulator is operational. Since the overcurrent protection on the linear regulators is performed through undervoltage monitoring at the feedback pins (FB2, FB3, and FB4), this feature is activated approximately 25% into the soft-start interval (see Figure 2).

A resistor (R<sub>OCSET</sub>) programs the overcurrent trip level for the PWM converter. As shown in Figure 3, the internal 40μA current sink (I<sub>OCSET</sub>) develops a voltage across R<sub>OCSET</sub> (V<sub>SET</sub>) that is referenced to V<sub>IN</sub>. The DRIVE signal enables the overcurrent comparator (OCC). When the voltage across the upper MOSFET (V<sub>DS(ON)</sub>) exceeds V<sub>SET</sub>, the overcurrent comparator trips to set the overcurrent latch. Both V<sub>SET</sub> and V<sub>DS(ON)</sub> are referenced to V<sub>IN</sub> and a small capacitor across R<sub>OCSET</sub> helps V<sub>OCSET</sub> track the variations of V<sub>IN</sub> due to MOSFET switching. The overcurrent function will trip at a peak inductor current (I<sub>PEAK</sub>) determined by:

$$I_{PEAK} = \frac{I_{OCSET} \times R_{OCSET}}{r_{DS(ON)}}$$

The OC trip point varies with MOSFET's r<sub>DS(ON)</sub> temperature variations. To avoid overcurrent tripping in the normal operating load range, determine the R<sub>OCSET</sub> resistor from the equation above with:



equally large amounts of noise. The critical small signal components are those connected to sensitive nodes or those supplying critical bypass current.

The power components and the controller IC should be placed first. Locate the input capacitors, especially the high-frequency ceramic decoupling capacitors, close to the power switches. Locate the output inductor and output capacitors between the MOSFETs and the load. Locate the PWM controller close to the MOSFETs.

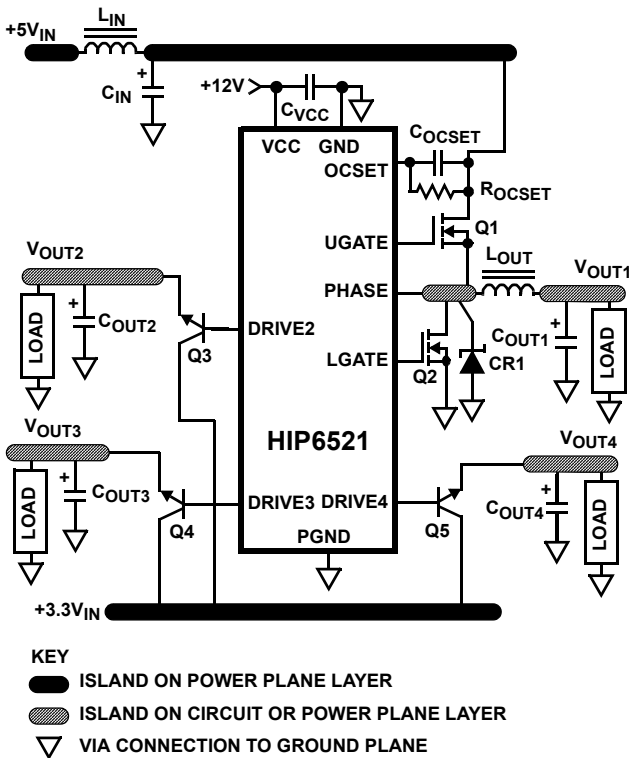

FIGURE 5. PRINTED CIRCUIT BOARD POWER PLANES AND ISLANDS

The critical small signal components include the bypass capacitor for VCC and the feedback resistors. Locate these components close to their connecting pins on the control IC.

A multi-layer printed circuit board is recommended. Figure 5 shows the connections of the critical components in the converter. Note that the capacitors  $C_{IN}$  and  $C_{OUT}$  each represent numerous physical capacitors. Dedicate one solid layer for a ground plane and make all critical component ground connections with vias to this layer. Dedicate another solid layer as a power plane and break this plane into smaller islands of common voltage levels. The power plane should support the input power and output power nodes. Use copper filled polygons on the top and bottom circuit layers for the PHASE nodes, but do not unnecessarily oversize these particular islands. Since the PHASE nodes are subjected to very high  $dV/dt$  voltages,

the stray capacitor formed between these islands and the surrounding circuitry will tend to couple switching noise. Use the remaining printed circuit layers for small signal wiring. The wiring traces from the control IC to the MOSFET gate and source should be sized to carry 2A peak currents.

**PWM Controller Feedback Compensation**

The PWM controller uses voltage-mode control for output regulation. This section highlights the design consideration for a PWM voltage-mode controller. Apply the methods and considerations only to the PWM controller.

Figure 6 highlights the voltage-mode control loop for a synchronous-rectified buck converter. The output voltage ( $V_{OUT}$ ) is regulated to the Reference voltage level, 0.8V. The error amplifier (Error Amp) output ( $V_{E/A}$ ) is compared with the oscillator (OSC) triangular wave to provide a pulse-width modulated (PWM) wave with an amplitude of  $V_{IN}$  at the PHASE node. The PWM wave is smoothed by the output filter ( $L_O$  and  $C_O$ ).

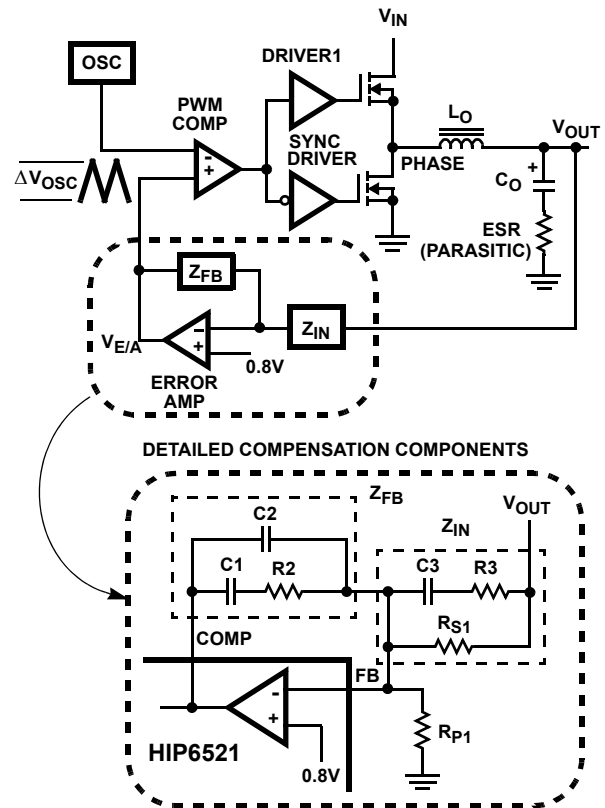

FIGURE 6. VOLTAGE-MODE BUCK CONVERTER COMPENSATION DESIGN

The modulator transfer function is the small-signal transfer function of  $V_{OUT}/V_{E/A}$ . This function is dominated by a DC Gain, given by  $V_{IN}/V_{OSC}$ , and shaped by the output filter, with a double pole break frequency at  $F_{LC}$  and a zero at  $F_{ESR}$ .



**Modulator Break Frequency Equations**

$$F_{LC} = \frac{1}{2\pi \times \sqrt{L_O \times C_O}} \quad F_{ESR} = \frac{1}{2\pi \times ESR \times C_O}$$

The compensation network consists of the error amplifier (internal to the HIP6521) and the impedance networks  $Z_{IN}$  and  $Z_{FB}$ . The goal of the compensation network is to provide a closed loop transfer function with high 0dB crossing frequency ( $f_{0dB}$ ) and adequate phase margin. Phase margin is the difference between the closed loop phase at  $f_{0dB}$  and 180°. The equations below relate the compensation network's poles, zeros and gain to the components (R1, R2, R3, C1, C2, and C3) in Figure 6. Use these guidelines for locating the poles and zeros of the compensation network:

1. Pick Gain (R2/R1) for desired converter bandwidth
2. Place 1<sup>ST</sup> Zero Below Filter's Double Pole (~75%  $F_{LC}$ )
3. Place 2<sup>ND</sup> Zero at Filter's Double Pole
4. Place 1<sup>ST</sup> Pole at the ESR Zero
5. Place 2<sup>ND</sup> Pole at Half the Switching Frequency
6. Check Gain against Error Amplifier's Open-Loop Gain
7. Estimate Phase Margin - Repeat if Necessary

**Compensation Break Frequency Equations**

$$F_{Z1} = \frac{1}{2\pi \times R2 \times C1} \quad F_{P1} = \frac{1}{2\pi \times R2 \times \left(\frac{C1 \times C2}{C1 + C2}\right)}$$

$$F_{Z2} = \frac{1}{2\pi \times (R_{S1} + R3) \times C3} \quad F_{P2} = \frac{1}{2\pi \times R3 \times C3}$$

Figure 7 shows an asymptotic plot of the DC/DC converter's gain vs. frequency. The actual Modulator Gain has a high gain peak dependent on the quality factor (Q) of the output filter, which is not shown in Figure 6. Using the above guidelines should yield a Compensation Gain similar to the curve plotted. The open loop error amplifier gain bounds the compensation gain. Check the compensation gain at  $F_{P2}$  with the capabilities of the error amplifier. The Closed Loop Gain is constructed on the log-log graph of Figure 10 by adding the Modulator Gain (in dB) to the Compensation Gain (in dB). This is equivalent to multiplying the modulator transfer function to the compensation transfer function and plotting the gain.

The compensation gain uses external impedance networks  $Z_{FB}$  and  $Z_{IN}$  to provide a stable, high bandwidth (BW) overall loop. A stable control loop has a gain crossing with -20dB/decade slope and a phase margin greater than 45°. Include worst case component variations when determining phase margin.

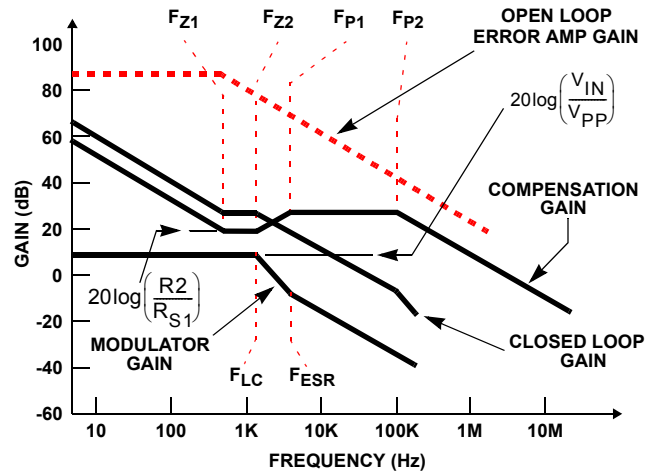

**FIGURE 7. ASYMPTOTIC BODE PLOT OF CONVERTER GAIN**

**ACPI Implementation**

The three linear controllers included within the HIP6521 can independently be shut down, in order to accommodate Advanced Configuration and Power Interface (ACPI) power management features.

To shut down any of the linears, one needs to pull and keep high the respective FB pin above a typical threshold of 1.25V. One way to achieve this task is by using a logic gate coupled through a small-signal diode. The diode should be placed as close to the FB pin as possible to minimize stray capacitance to this pin. Upon turn-off of the pull-up device, the respective output undergoes a soft-start cycle, bringing the output within regulation limits. On the regulators implementing this feature, the parallel combination of the feedback resistors has to be sufficiently high to allow ease of driving from the external device. Considering the other restriction applying to the upper range of this resistor combination (see 'Output Voltage Selection' paragraph), it is recommended the values of the feedback resistors on an ACPI-enabled linear regulator output meet the following constraint:

$$2k\Omega < \frac{R_S \times R_P}{R_S + R_P} < 5k\Omega$$

To turn off the switching regulator, use an open-drain or open-collector device capable of pulling the OCSET pin (with the attached  $R_{OCSET}$  pull-up) below 1.25V. To minimize the possibility of OC trips at levels different than predicted, a  $C_{OCSET}$  capacitor with a value of an order of magnitude larger than the output capacitance of the pull-down device, has to be used in parallel with  $R_{OCSET}$  (1nF recommended). Upon turn-off of the pull-down device, the switching regulator undergoes a soft-start cycle.

**Important**

If the collector voltage to a linear regulator pass transistor (Q3, Q4, or Q5) is lost, the respective regulator has to be shut down by pulling high its FB pin (i.e., when an input power rail shuts down as a result of entering a sleep state, the affected regulator's FB pin has to be pulled high). This measure is necessary in order to avoid possible damage to the HIP6521 as a result of overheating. Overheating can occur in such situations due to sheer power dissipation inside the chip's output linear drivers.

**Component Selection Guidelines****Output Capacitor Selection**

The output capacitors for each output have unique requirements. In general, the output capacitors should be selected to meet the dynamic regulation requirements. Additionally, the PWM converters require an output capacitor to filter the current ripple. The load transient for the microprocessor core requires high quality capacitors to supply the high slew rate (di/dt) current demands.

**PWM Output Capacitors**

Modern microprocessors produce transient load rates above 1A/ns. High frequency capacitors initially supply the transient current and slow the load rate-of-change seen by the bulk capacitors. The bulk filter capacitor values are generally determined by the ESR (effective series resistance) and voltage rating requirements rather than actual capacitance requirements.

High frequency decoupling capacitors should be placed as close to the power pins of the load as physically possible. Be careful not to add inductance in the circuit board wiring that could cancel the usefulness of these low inductance components. Consult with the manufacturer of the load on specific decoupling requirements.

Use only specialized low-ESR capacitors intended for switching-regulator applications for the bulk capacitors. The bulk capacitor's ESR determines the output ripple voltage and the initial voltage drop following a high slew-rate transient's edge. An aluminum electrolytic capacitor's ESR value is related to the case size with lower ESR available in larger case sizes. However, the equivalent series inductance (ESL) of these capacitors increases with case size and can reduce the usefulness of the capacitor to high slew-rate transient loading. Unfortunately, ESL is not a specified parameter. Work with your capacitor supplier and measure the capacitor's impedance with frequency to select a suitable component. In most cases, multiple electrolytic capacitors of small case size perform better than a single large case capacitor.

**Linear Output Capacitors**

The output capacitors for the linear regulators provide dynamic load current. The linear controllers use dominant

pole compensation integrated into the error amplifier and are insensitive to output capacitor selection. Output capacitors should be selected for transient load regulation.

**PWM Output Inductor Selection**

The PWM converter requires an output inductor. The output inductor is selected to meet the output voltage ripple requirements and sets the converter's response time to a load transient. The inductor value determines the converter's ripple current and the ripple voltage is a function of the ripple current. The ripple voltage and current are approximated by the following equations:

$$\Delta I = \frac{V_{IN} - V_{OUT}}{F_S \times L} \times \frac{V_{OUT}}{V_{IN}} \quad \Delta V_{OUT} = \Delta I \times ESR$$

Increasing the value of inductance reduces the ripple current and voltage. However, the large inductance values increase the converter's response time to a load transient.

One of the parameters limiting the converter's response to a load transient is the time required to change the inductor current. Given a sufficiently fast control loop design, the HIP6521 will provide either 0% or 100% duty cycle in response to a load transient. The response time is the time interval required to slew the inductor current from an initial current value to the post-transient current level. During this interval the difference between the inductor current and the transient current level must be supplied by the output capacitor(s). Minimizing the response time can minimize the output capacitance required.

The response time to a transient is different for the application of load and the removal of load. The following equations give the approximate response time interval for application and removal of a transient load:

$$t_{RISE} = \frac{L_O \times I_{TRAN}}{V_{IN} - V_{OUT}} \quad t_{FALL} = \frac{L_O \times I_{TRAN}}{V_{OUT}}$$

where:  $I_{TRAN}$  is the transient load current step,  $t_{RISE}$  is the response time to the application of load, and  $t_{FALL}$  is the response time to the removal of load. Be sure to check both of these equations at the minimum and maximum output levels for the worst case response time.

**Input Capacitor Selection**

The important parameters for the bulk input capacitors are the voltage rating and the RMS current rating. For reliable operation, select bulk input capacitors with voltage and current ratings above the maximum input voltage and largest RMS current required by the circuit. The capacitor voltage rating should be at least 1.25 times greater than the maximum input voltage and a voltage rating of 1.5 times is a conservative guideline. The RMS current rating requirement for the input capacitor of a buck regulator is approximately 1/2 of the summation of the DC load current.

Use a mix of input bypass capacitors to control the voltage overshoot across the MOSFETs. Use ceramic capacitance for the high frequency decoupling and bulk capacitors to supply the RMS current. Small ceramic capacitors can be placed very close to the upper MOSFET to suppress the voltage induced in the parasitic circuit impedances.

For a through-hole design, several electrolytic capacitors may be needed. For surface mount designs, solid tantalum capacitors can be used, but caution must be exercised with regard to the capacitor surge current rating. These capacitors must be capable of handling the surge-current at power-up.

**Transistors Selection/Considerations**

The HIP6521 requires 5 external transistors. Two N-channel MOSFETs are used in the synchronous-rectified buck topology of PWM converter. The clock, AGP and MCH/ICH linear controllers each drive an NPN bipolar transistor as a pass element. All these transistors should be selected based upon  $r_{DS(ON)}$ , current gain, saturation voltages, gate/base supply requirements, and thermal management considerations.

**PWM MOSFET Selection and Considerations**

In high-current PWM applications, the MOSFET power dissipation, package selection and heatsink are the dominant design factors. The power dissipation includes two loss components; conduction loss and switching loss. These losses are distributed between the upper and lower MOSFETs according to duty factor (see the equations below). The conduction losses are the main component of power dissipation for the lower MOSFETs. Only the upper MOSFET has significant switching losses, since the lower device turns on and off into near zero voltage.

The equations below assume linear voltage-current transitions and do not model power loss due to the reverse-recovery of the lower MOSFET's body diode. The gate-charge losses are dissipated by the HIP6521 and don't heat the MOSFETs. However, large gate-charge increases the switching time,  $t_{SW}$  which increases the upper MOSFET switching losses. Ensure that both MOSFETs are within their maximum junction temperature at high ambient temperature by calculating the temperature rise according to package thermal-resistance specifications. A separate heatsink may be necessary depending upon MOSFET power, package type, ambient temperature and air flow.

$$P_{UPPER} = \frac{I_O^2 \times r_{DS(ON)} \times V_{OUT}}{V_{IN}} + \frac{I_O \times V_{IN} \times t_{SW} \times F_S}{2}$$

$$P_{LOWER} = \frac{I_O^2 \times r_{DS(ON)} \times (V_{IN} - V_{OUT})}{V_{IN}}$$

Given the reduced available gate bias voltage (5V) logic-level or sub-logic-level transistors have to be used for both N-MOSFETs. Caution should be exercised with devices exhibiting very low  $V_{GS(ON)}$  characteristics, as the low gate threshold could be conducive to some shoot-through (due to the Miller effect), in spite of the counteracting circuitry present aboard the HIP6521.

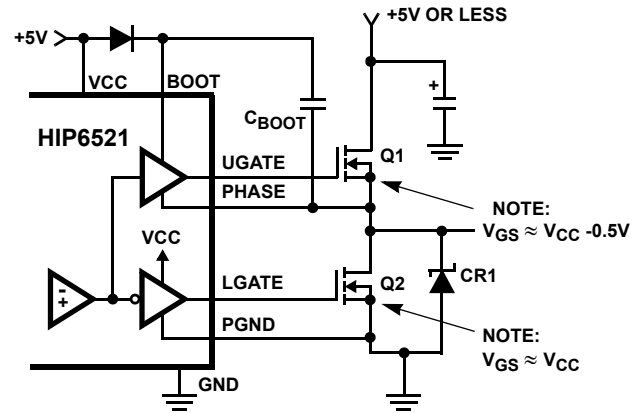

FIGURE 8. MOSFET GATE BIAS

Rectifier CR1 is a clamp that catches the negative inductor swing during the dead time between the turn off of the lower MOSFET and the turn on of the upper MOSFET. The diode must be a Schottky type to prevent the lossy parasitic MOSFET body diode from conducting. It is acceptable to omit the diode and let the body diode of the lower MOSFET clamp the negative inductor swing, providing the body diode is fast enough to avoid excessive negative voltage swings at the PHASE pin. The diode's rated reverse breakdown voltage must be greater than the maximum input voltage.

**Linear Controllers Transistor Selection**

The main criteria for selection of transistors for the linear regulators is package selection for efficient removal of heat. The power dissipated in a linear regulator is:

$$P_{LINEAR} = I_O \times (V_{IN} - V_{OUT})$$

Select a package and heatsink that maintains the junction temperature below the rating with a the maximum expected ambient temperature.

As bipolar NPN transistors have to be used with the linear controllers, insure the current gain at the given operating  $V_{CE}$  is sufficiently large to provide the desired maximum output load current when the base is fed with the minimum driver output current.

### HIP6521 DC/DC Converter Application Circuit

Figure 9 shows an application circuit of a power supply for a microprocessor computer system. The power supply provides the system memory voltage ( $V_{OUT1}$ ), the AGP bus voltage ( $V_{OUT4}$ ), the clock voltage ( $V_{OUT2}$ ), and the chip set core

voltage ( $V_{OUT3}$ ) from  $+5V_{DUAL}$ . For detailed information on the circuit, including a Bill-of-Materials and circuit board description, see Application Note AN9908. Also see Intersil's web page ([www.intersil.com](http://www.intersil.com)) for the latest information.

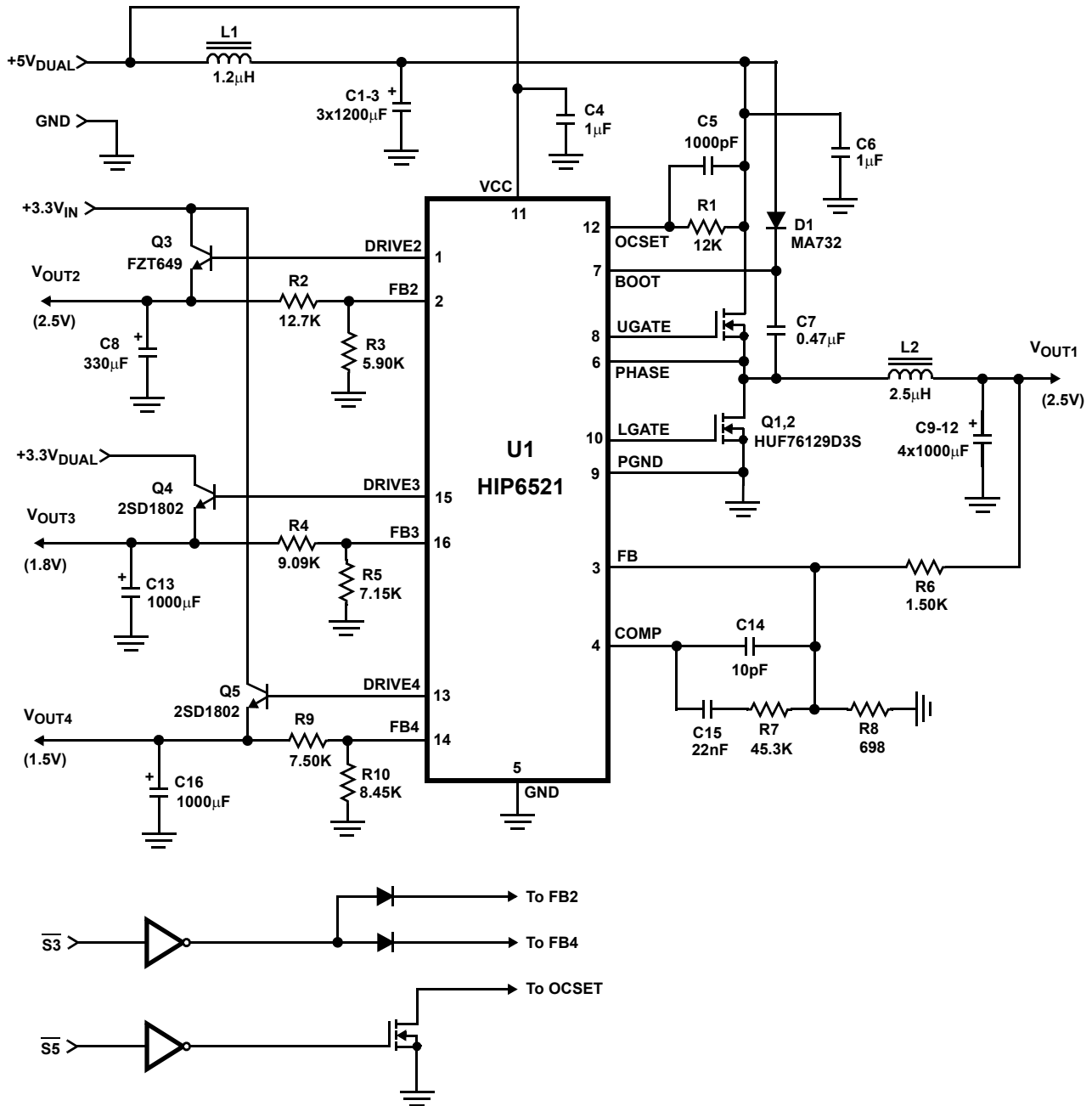
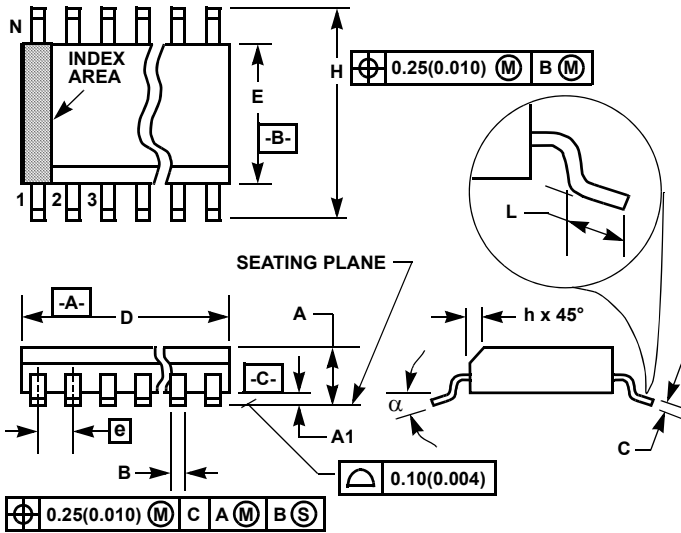

FIGURE 9. POWER SUPPLY APPLICATION CIRCUIT FOR A MICROPROCESSOR COMPUTER SYSTEM

**Small Outline Plastic Packages (SOIC)**



**M16.15 (JEDEC MS-012-AC ISSUE C)  
16 LEAD NARROW BODY SMALL OUTLINE PLASTIC PACKAGE**

SYMBOL	INCHES		MILLIMETERS		NOTES
	MIN	MAX	MIN	MAX	
A	0.0532	0.0688	1.35	1.75	-
A1	0.0040	0.0098	0.10	0.25	-
B	0.013	0.020	0.33	0.51	9
C	0.0075	0.0098	0.19	0.25	-
D	0.3859	0.3937	9.80	10.00	3
E	0.1497	0.1574	3.80	4.00	4
e	0.050 BSC		1.27 BSC		-
H	0.2284	0.2440	5.80	6.20	-
h	0.0099	0.0196	0.25	0.50	5
L	0.016	0.050	0.40	1.27	6
N	16		16		7
alpha	0°	8°	0°	8°	-

**NOTES:**

1. Symbols are defined in the "MO Series Symbol List" in Section 2.2 of Publication Number 95.
2. Dimensioning and tolerancing per ANSI Y14.5M-1982.
3. Dimension "D" does not include mold flash, protrusions or gate burrs. Mold flash, protrusion and gate burrs shall not exceed 0.15mm (0.006 inch) per side.
4. Dimension "E" does not include interlead flash or protrusions. Interlead flash and protrusions shall not exceed 0.25mm (0.010 inch) per side.
5. The chamfer on the body is optional. If it is not present, a visual index feature must be located within the crosshatched area.
6. "L" is the length of terminal for soldering to a substrate.
7. "N" is the number of terminal positions.
8. Terminal numbers are shown for reference only.
9. The lead width "B", as measured 0.36mm (0.014 inch) or greater above the seating plane, shall not exceed a maximum value of 0.61mm (0.024 inch).
10. Controlling dimension: MILLIMETER. Converted inch dimensions are not necessarily exact.

Rev. 1 6/05

© Copyright Intersil Americas LLC 2005-2006. All Rights Reserved.  
All trademarks and registered trademarks are the property of their respective owners.

For additional products, see [www.intersil.com/en/products.html](http://www.intersil.com/en/products.html)

Intersil products are manufactured, assembled and tested utilizing ISO9001 quality systems as noted in the quality certifications found at [www.intersil.com/en/support/qualandreliability.html](http://www.intersil.com/en/support/qualandreliability.html)

*Intersil products are sold by description only. Intersil may modify the circuit design and/or specifications of products at any time without notice, provided that such modification does not, in Intersil's sole judgment, affect the form, fit or function of the product. Accordingly, the reader is cautioned to verify that datasheets are current before placing orders. Information furnished by Intersil is believed to be accurate and reliable. However, no responsibility is assumed by Intersil or its subsidiaries for its use; nor for any infringements of patents or other rights of third parties which may result from its use. No license is granted by implication or otherwise under any patent or patent rights of Intersil or its subsidiaries.*

For information regarding Intersil Corporation and its products, see [www.intersil.com](http://www.intersil.com)