

THIS DRAWING IS UNPUBLISHED. RELEASED FOR PUBLICATION  
 © COPYRIGHT - By - ALL RIGHTS RESERVED.

REVISIONS					
P	LTR	DESCRIPTION	DATE	DWN	APVD
G2		REVISED PER ECR-17-013854	22SEP2017	BDA	KR

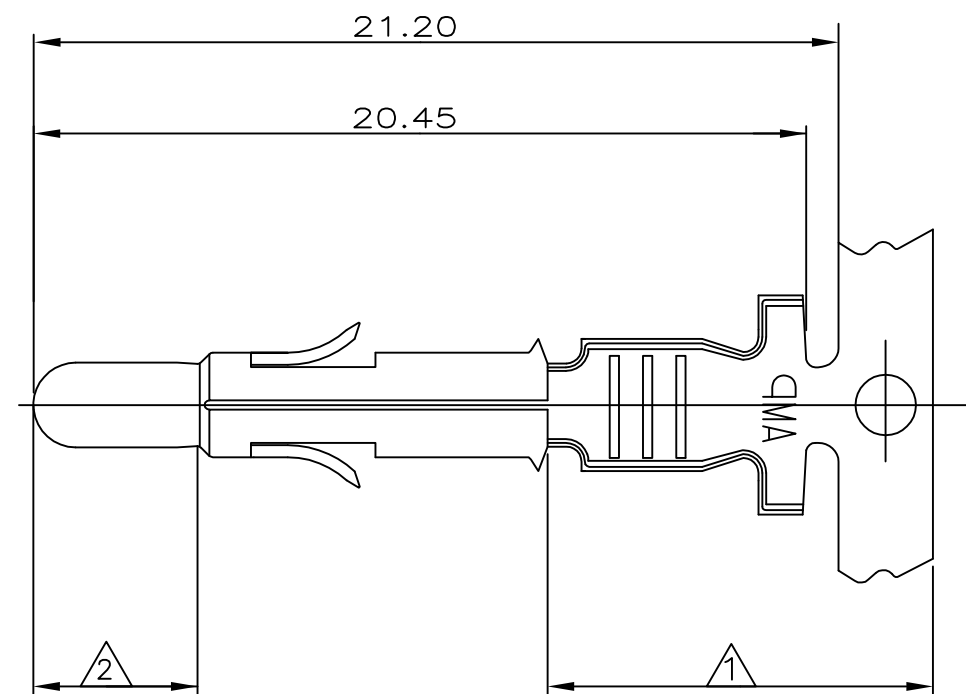
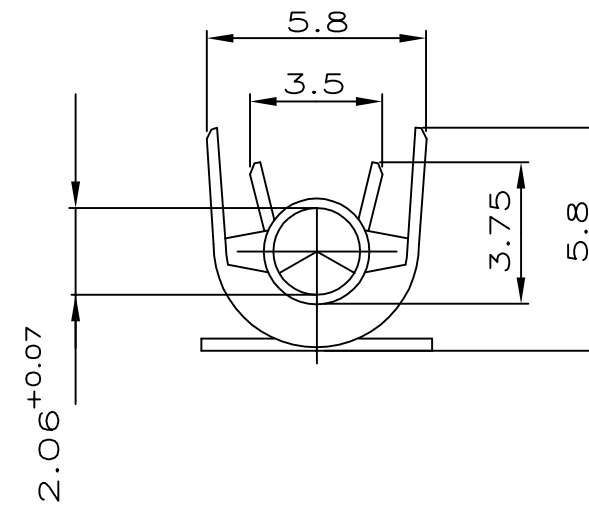
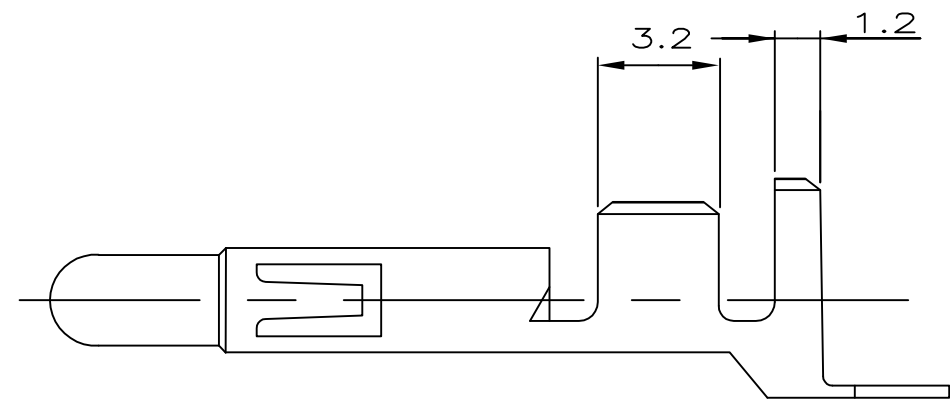

- 1 2-6 µm Sn über Ni in der Crimpzone
- 2 0.8 µm Gold über Nickel in der kontaktzone
- 3 Für isolations Ø3.3-5.1 mm geeignet

	926900-7	926868-7	CuZn30 F53	1 2
	926900-6	926868-6	CuSn4 F56	1 2
OBSOLETE	926900-5	926868-5	CuCrZr F50	vorverzinnt
OBSOLETE	926900-4	926868-4	CuCrZr F50	blank
	926900-3	926868-3	CuSn4 F56	vorverzinnt
	926900-1	926868-1	CuZn30 F53	vorverzinnt
	LOOSE PIECE	Bestell-Nr	werkstoff	Oberfläche Farbe

THIS DRAWING IS A CONTROLLED DOCUMENT.		DWN	21OCT2013	 TE Connectivity Universal M-N-L Stift DGB 1.5-2.5mm <sup>2</sup>			
DIMENSIONS:		CHK	21OCT2013				
mm		APVD	21OCT2013				
TOLERANCES UNLESS OTHERWISE SPECIFIED:		PRODUCT SPEC	NAME				
0 PLC	± -	APPLICATION SPEC	NAME	SIZE	CAGE CODE	DRAWING NO	RESTRICTED TO
1 PLC	± -		RAJENDRA PAI	A2	00779	C=926868	-
2 PLC	± 0.20			CUSTOMER DRAWING	SCALE	SHEET	REV
3 PLC	± -				1:1	1 of 1	G2
4 PLC	± -						
ANGLES	± -						
FINISH	-						

# Mouser Electronics

Authorized Distributor

Click to View Pricing, Inventory, Delivery & Lifecycle Information:

[TE Connectivity:](#)

[926868-3](#)