

SYMBOL DEFINITION		MISSING SYMBOLS	
A DIMENSION WITHOUT AN INSPECTION REPORT SYMBOL DOES NOT REQUIRE INSPECTION. IT MAY BE CONTROLLED ON THE INDIVIDUAL COMPONENT DRAWING.	TOTAL NO OF INSPECTIONS REQUIRED	NO MISSING SYMBOL NUMBER	
	17		
	LAST NO. USED	8	

DWO STATUS						REVISION HISTORY				AUTH	DR	APVD	APVD
DATE	STG	REV	N/P	CHG	ZONE								
20AU01	R	01	-	-		WAS PE082094 & RELEASED				212995	EES	JMR	MJC
22AU01	R	02	-	-		2X 11.4 WAS 2X 10.94				213573	CJP	CJP	MJC
11SE01	R	03	-	-		ADDED APPROCH ANGLE TO LOCK ARMS				214289	BRB	BRB	MJC
11DE01	R	03	AA	-		ADDED 3X 5.6, PSD WAS 6				218604	CJP	CJP	MC
09DE03	R	03	AB	-		2X 6.04 +0.15/-0.3 WAS 2X 6.04; 21.09 +0.2/-0.5 WAS 21.09				249833	ADK	ADK	MC

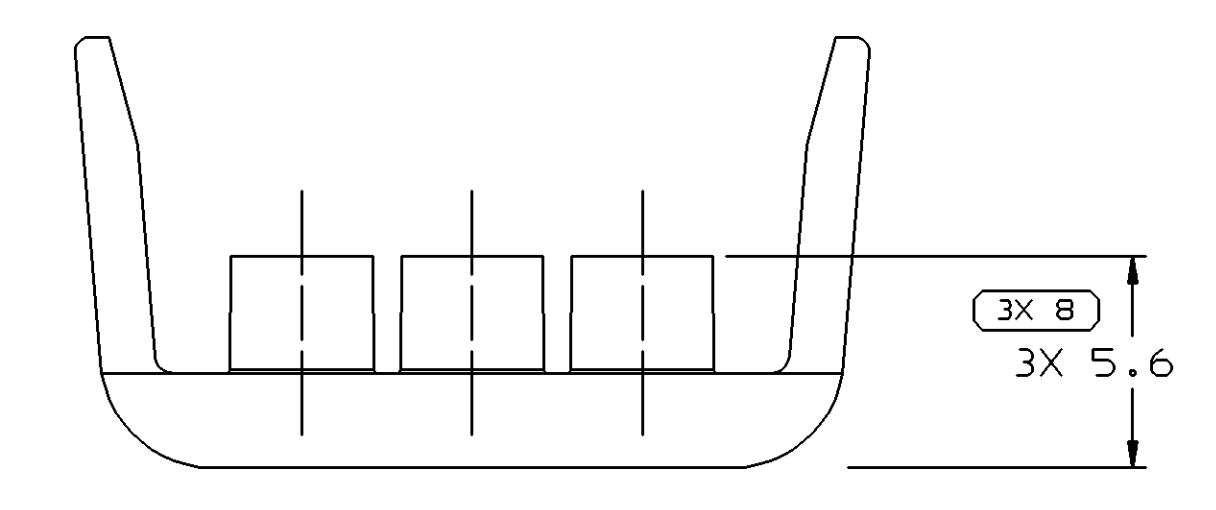
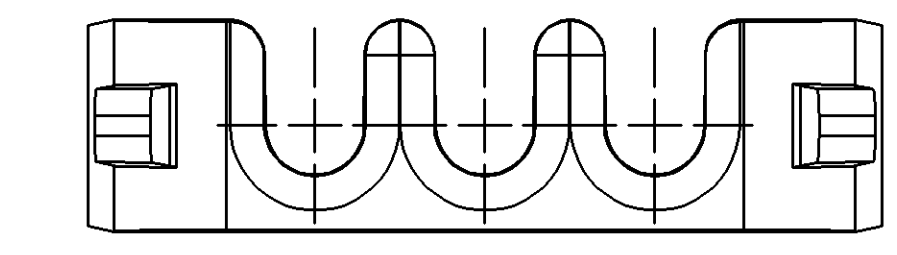
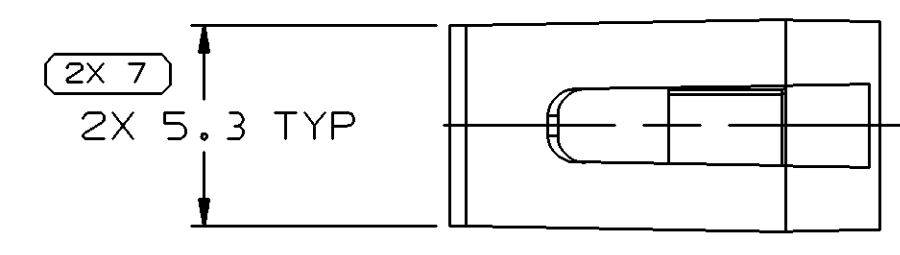
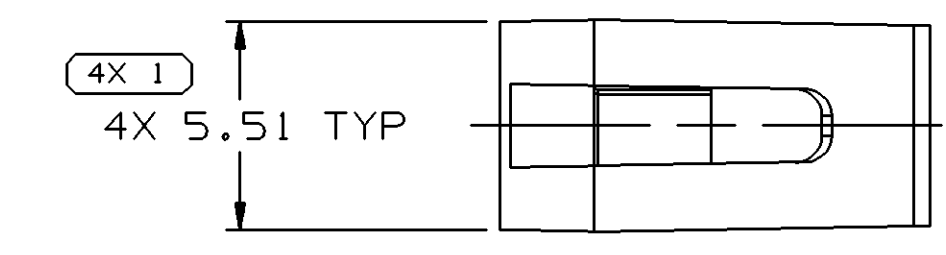
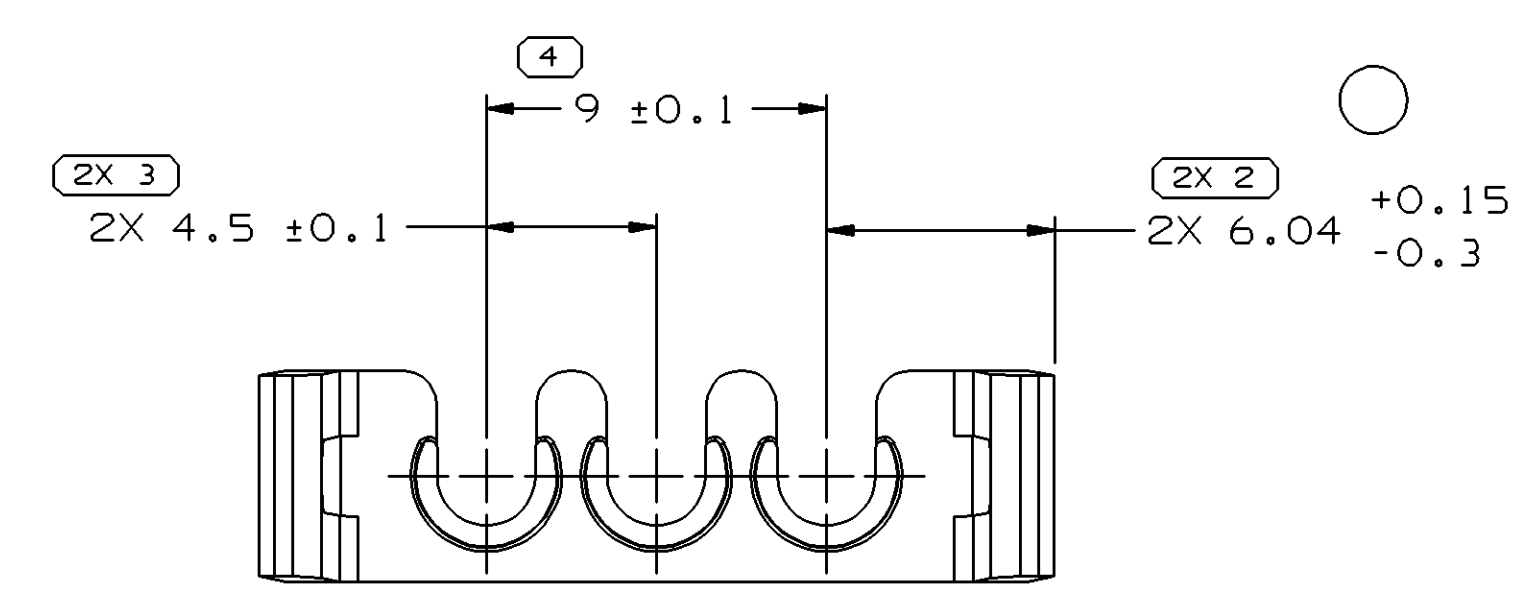
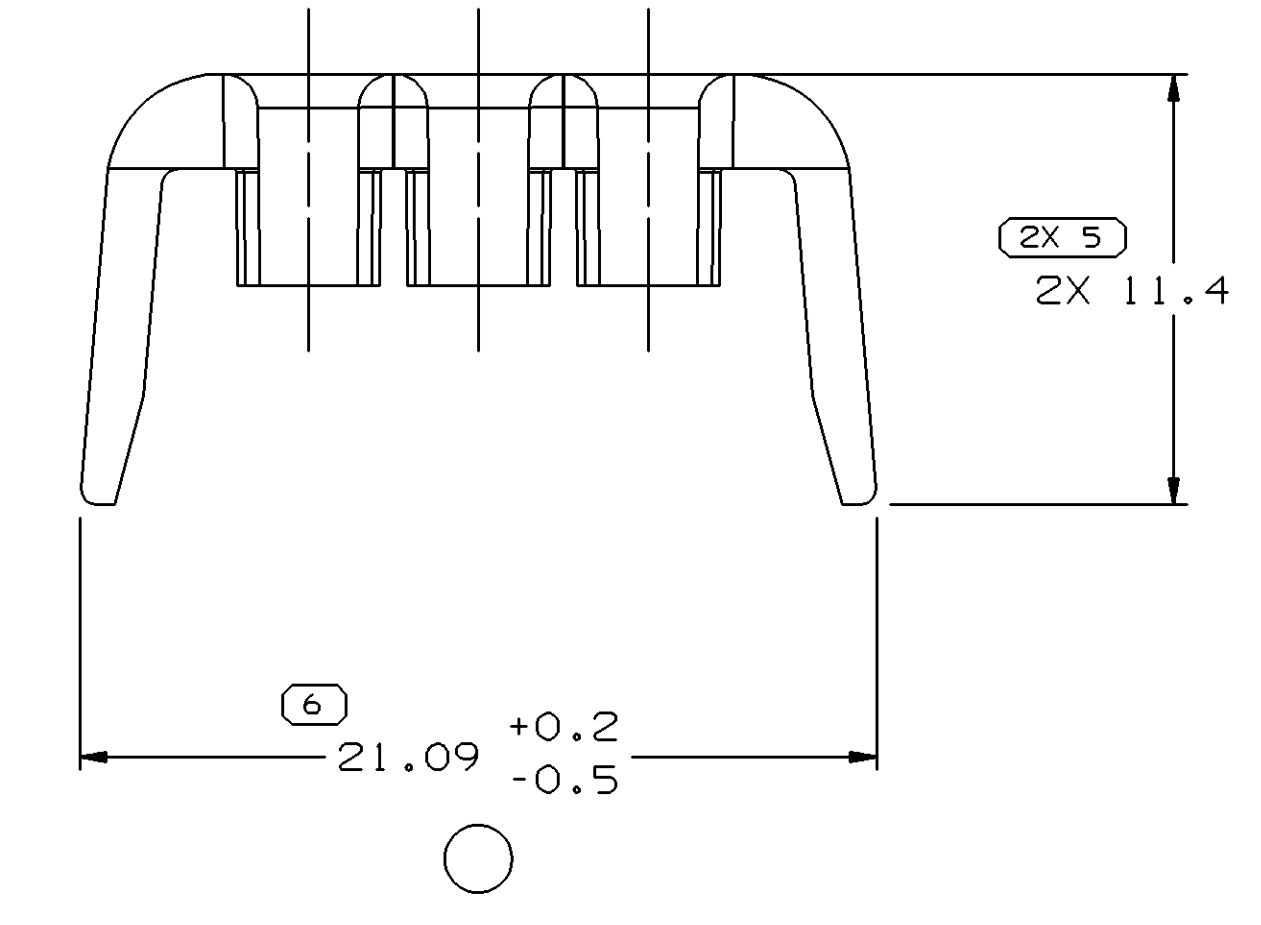

NOTES

- UNLESS OTHERWISE SPECIFIED AND/OR INDICATED: DIMENSIONS ARE TO FACE OF VIEW SHOWN AND AUTOMATICALLY ROUNDED BY COMPUTER FOR INSPECTION (SEE MATH MODEL FOR PRECISE DIMENSIONS). FOR ALL OTHER DIMENSIONS NOT SHOWN BUT REQUIRED FOR TOOL BUILD, SEE MATH MODEL FOR PRECISE TOOL PATH DATA. ALL RADII 0.4 DRAFT IS 1° ON ALL OUTSIDE SURFACES LIKE CAVITIES ARE IDENTICAL LOCKING FEATURES ARE IDENTICAL
- TOOL CAVITY IDENTIFICATION SHOULD BE LOCATED AS CLOSE TO THE GATE AS POSSIBLE.
- MATING COMPONENTS OR EQUIVALENT: CONNECTOR 15326807

DWO TYPE		PART DRAWING	
STYLE		GMT - 360	
VOLUME (OP)	0,290	DISTR CODE	D
ROUTING	6901		
UNLESS OTHERWISE SPECIFIED			
THIS DOCUMENT IS IN ACCORDANCE WITH ASME Y14.5M-1994 AS MODIFIED BY THE DIMENSIONAL DIMENSIONS AND TOLERANCING ADDENDUM-2003. SEPARATE PATTERNING OF FEATURES MAY BE OBTAINED SEPARATELY REGARDLESS OF DATUM REFERENCES.			
ALL DIMENSIONS ARE IN MILLIMETERS			
REFERENCE			

DELPHI
DELPHI PACKARD ELECTRIC SYSTEMS
WARREN, OH

DR	DATE
APVD1 E. SEIDEL	20AU01
APVD2 J. RICHARDSON	20AU01
APVD3 M. CULP	20AU01
APVD4	
APVD5	

SUBSTANCES OF CONCERN AND RECYCLED CONTENT PER DELPHI 10949001

MATERIAL M3571009 PA6 (GB20+GF10) H5 - PPL

DRAWING NAME
LOCK TPA GT 150 3 PPL

DRAWING NUMBER
15418545

SIZE A0 SCALE 5:1 FRAME NO 1 OF 1 SHEET NO 1 OF 1 REV N/P R 03 AB

R 0.2 MAX	R 0.1 MAX	DIMENSIONAL RANGE (MM)		CHART ET	
		FROM	TO	FROM	TO
		> 0	> 20	> 30	> 70
		> 20	> 30	> 70	> 100
		> 30	> 70	> 100	> 150
		> 70	> 100	> 150	> 200
		> 100	> 150	> 200	> 250
		> 150	> 200	> 250	> 300
		> 200	> 250	> 300	> 400
		TOLERANCE UNLESS OTHERWISE SPECIFIED			
		±0.15	±0.2	±0.3	±0.4
		±0.4	±0.5	±0.6	±0.8
		±1	±1.2	ANGULAR TOLERANCE ±2°	

Mouser Electronics

Authorized Distributor

Click to View Pricing, Inventory, Delivery & Lifecycle Information:

[Aptiv:](#)

[15418545](#)