

Normally closed DIP6-pin economic type with reinforced insulation

PhotoMOS[®]
GU-E 1 Form B
 (AQV414E, AQV410EH)

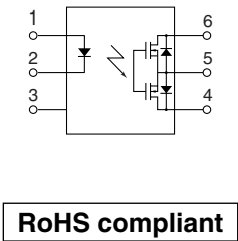
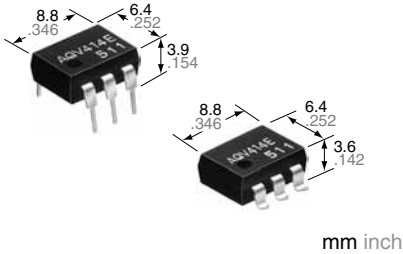

FEATURES

- High cost-performance type of PhotoMOS 1 Form B output**
- 60V type couples high capacity (0.55A) with low on-resistance (typ. 1Ω).**
- Low on-resistance**

This has been realized thanks to the built-in MOSFET processed by our proprietary method, DSD (Double-diffused and Selective Doping) method.

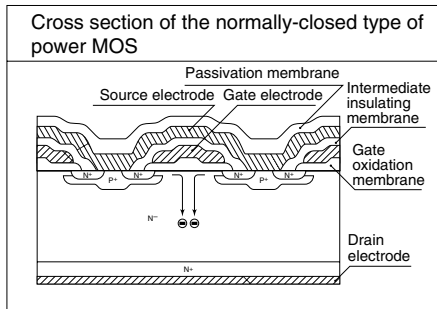

- Controls low-level analog signals**
PhotoMOS feature extremely low closed-circuit offset voltage to enable control of low-level analog signals without distortion.

- High sensitivity and low on-resistance**

Can control max. 0.55 A load current with 5 mA input current.

Low on-resistance of typ. 1Ω (AQV412EH).

- Low-level off-state leakage current of max. 1 μA (AQV414E)**

- Reinforced insulation 5,000 V type also available**

More than 0.4 mm internal insulation distance between inputs and outputs. Conforms to EN41003, EN60950 (reinforced insulation).

TYPICAL APPLICATIONS

- Power supply
- Measuring equipment
- Security equipment
- Telephone equipment
- Sensing equipment

TYPES

	I/O isolation voltage	Output rating*		Package	Part No.				Packing quantity	
		Load voltage	Load current		Through hole terminal	Surface-mount terminal			Tube	Tape and reel
						Tape and reel packing style				
					Tube packing style	Picked from the 1/2/3-pin side	Picked from the 4/5/6-pin side			
AC/DC dual use	1,500 V AC (Standard)	400 V	120 mA	DIP6-pin	AQV414E	AQV414EA	AQV414EAX	AQV414EAZ	1 tube contains: 50 pcs. 1 batch contains: 500 pcs.	1,000 pcs.
		60 V	550 mA		AQV412EH	AQV412EHA	AQV412EHAX	AQV412EHAZ		
	5,000 V AC (Reinforced)	350 V	130 mA		AQV410EH	AQV410EHA	AQV410EHAX	AQV410EHAZ		
		400 V	120 mA		AQV414EH	AQV414EHA	AQV414EHAX	AQV414EHAZ		

*Indicate the peak AC and DC values.

Note: The surface mount terminal shape indicator "A" and the packing style indicator "X" or "Z" are not marked on the device.

RATING

1. Absolute maximum ratings (Ambient temperature: 25°C 77°F)

Item	Symbol	Type of connection	AQV414E(A)	AQV412EH(A)	AQV410EH(A)	AQV414EH(A)	Remarks		
Input	LED forward current	I _F	50 mA						
	LED reverse voltage	V _R	5 V						
	Peak forward current	I _{FP}	1 A				f = 100 Hz, Duty factor = 0.1%		
	Power dissipation	P _{in}	75 mW						
Output	Load voltage (peak AC)	V _L	400 V	60 V	350 V	400 V			
	Continuous load current	I _L	A	0.12 A	0.55 A	0.13 A	0.12 A	A connection: Peak AC, DC B,C connection: DC	
			B	0.13 A	0.65 A	0.15 A	0.13 A		
			C	0.15 A	0.8 A	0.17 A	0.15 A		
	Peak load current	I _{peak}	0.3 A				1.5 A	0.4 A	0.3 A
Power dissipation	P _{out}	500 mW							
Total power dissipation	P _T	550 mW							
I/O isolation voltage	V _{iso}		1,500 V AC	5,000 V AC					
Temperature limits	Operating	T _{opr}	-40°C to +85°C -40°F to +185°F					Non-condensing at low temperatures	
	Storage	T _{stg}	-40°C to +100°C -40°F to +212°F						

GU-E 1 Form B (AQV414E, AQV410EH)

2. Electrical characteristics (Ambient temperature: 25°C 77°F)

Item		Symbol	Type of connection	AQV414E(A)	AQV412EH(A)	AQV410EH(A)	AQV414EH(A)	Condition	
Input	LED operate (OFF) current	Typical	—	1.45 mA	1.9 mA			I _L = Max.	
		Maximum			3.0 mA				
	LED reverse (ON) current	Minimum	—	0.3 mA	0.4 mA			I _L = Max.	
		Typical			1.40 mA	1.8 mA			
LED dropout voltage	Typical	V _F	—	1.25 V (1.14 V at I _F = 5 mA)				I _F = 50 mA	
	Maximum			1.5 V					
Output	On resistance	Typical	R _{on}	A	26 Ω	1 Ω	18 Ω	25.2 Ω	I _F = 0 mA I _L = Max. Within 1 s on time
		Maximum			50 Ω	2.5 Ω	35 Ω	50 Ω	
		Typical	R _{on}	B	20 Ω	0.55 Ω	13 Ω	19 Ω	I _F = 0 mA I _L = Max. Within 1 s on time
		Maximum			25 Ω	1.3 Ω	17.5 Ω	25 Ω	
	Typical	R _{on}	C	10 Ω	0.3 Ω	6.5 Ω	10 Ω	I _F = 0 mA I _L = Max. Within 1 s on time	
	Maximum			12.5 Ω	0.7 Ω	8.8 Ω	12.5 Ω		
Off state leakage current	Maximum	I _{Leak}	—	1 μA	10 μA			I _F = 5 mA V _L = Max.	
Transfer characteristics	Operate (OFF) time*	Typical	T _{off}	—	0.7 ms	3 ms	1.5 ms	1.3 ms	I _F = 0 mA → 5 mA I _L = Max.
		Maximum			2.0 ms	8 ms	3.0 ms		
	Reverse (ON) time*	Typical	T _{on}	—	0.1 ms	0.3 ms			I _F = 5 mA → 0 mA I _L = Max.
		Maximum			1.0 ms	1.5 ms			
	I/O capacitance	Typical	C _{iso}	—	0.8 pF				f = 1 MHz V _B = 0 V
Maximum		1.5 pF							
Initial I/O isolation resistance	Minimum	R _{iso}	—	1,000 MΩ				500 V DC	

*Operate/Reverse time

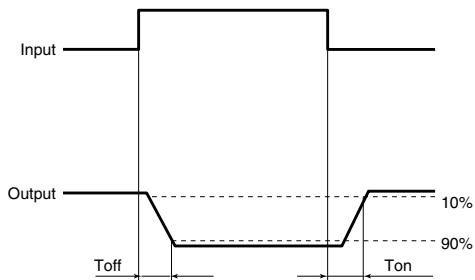

RECOMMENDED OPERATING CONDITIONS

Please obey the following conditions to ensure proper device operation and resetting.

Item	Symbol	Recommended value	Unit
Input LED current	I _F	Standard type: 5 Reinforced type: 5 to 10	mA

■ For Dimensions.

■ For Schematic and Wiring Diagrams.

■ For Cautions for Use.

■ These products are not designed for automotive use.

If you are considering to use these products for automotive applications, please contact your local Panasonic Corporation technical representative.

For more information.

REFERENCE DATA

1-(1). Load current vs. ambient temperature characteristics

Allowable ambient temperature: -40°C to $+85^{\circ}\text{C}$
 -40°F to $+185^{\circ}\text{F}$

Type of connection: A

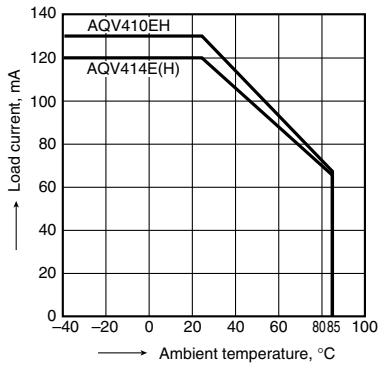

1-(2). Load current vs. ambient temperature characteristics

Allowable ambient temperature: -40°C to $+85^{\circ}\text{C}$
 -40°F to $+185^{\circ}\text{F}$

Type of connection: A

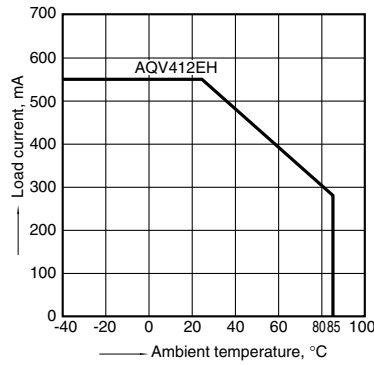

2. On resistance vs. ambient temperature characteristics

Measured portion: between terminals 4 and 6;
 LED current: 0 mA; Load voltage: Max. (DC);
 Continuous load current: Max. (DC)

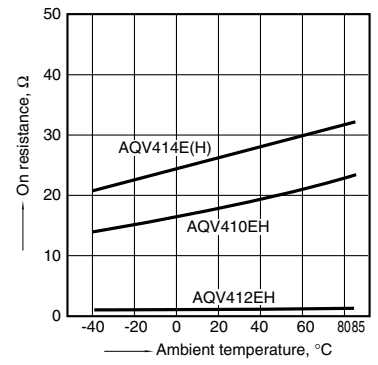

3. Operate (OFF) time vs. ambient temperature characteristics

LED current: 5 mA; Load voltage: Max. (DC);
 Continuous load current: Max. (DC)

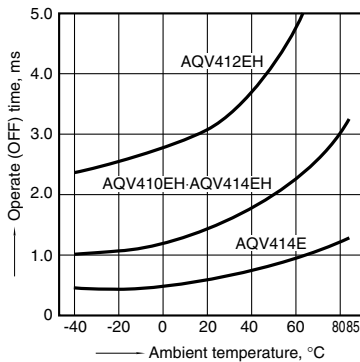

4. Reverse (ON) time vs. ambient temperature characteristics

LED current: 5 mA; Load voltage: Max. (DC);
 Continuous load current: Max. (DC)

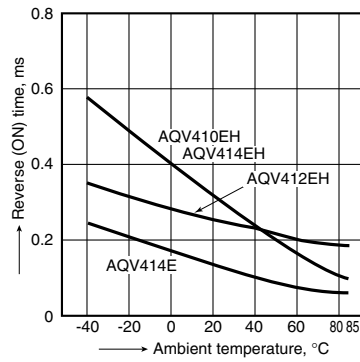

5. LED operate (OFF) current vs. ambient temperature characteristics

Load voltage: Max. (DC);
 Continuous load current: Max. (DC)

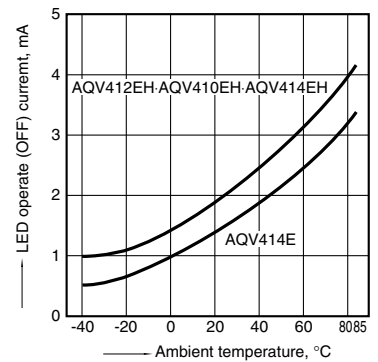

6. LED reverse (ON) current vs. ambient temperature characteristics

Load voltage: Max. (DC);
 Continuous load current: Max. (DC)

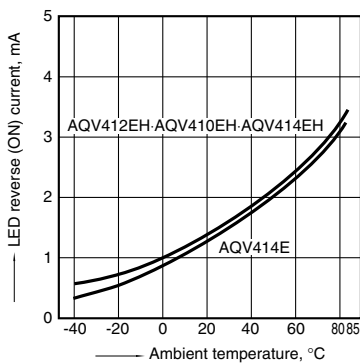

7. LED dropout voltage vs. ambient temperature characteristics

Sample: All types;
 LED current: 5 to 50 mA

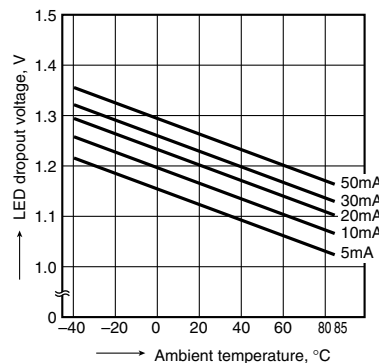

8-(1). Current vs. voltage characteristics of output at MOS portion

Measured portion: between terminals 4 and 6;
 Ambient temperature: 25°C 77°F

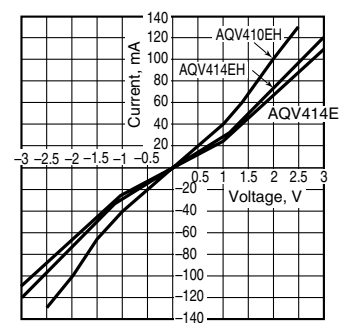

GU-E 1 Form B (AQV414E, AQV41EH)

8-(2). Current vs. voltage characteristics of output at MOS portion

Measured portion: between terminals 4 and 6;
Ambient temperature: 25°C 77°F

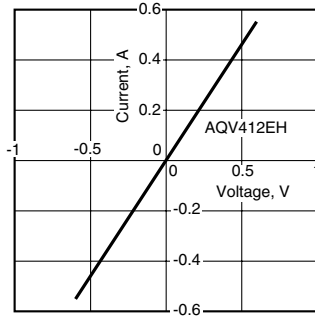

9. Off state leakage current vs. load voltage characteristics

Sample: All types;
Measured portion: between terminals 4 and 6;
LED current: 5 mA; Ambient temperature: 25°C 77°F

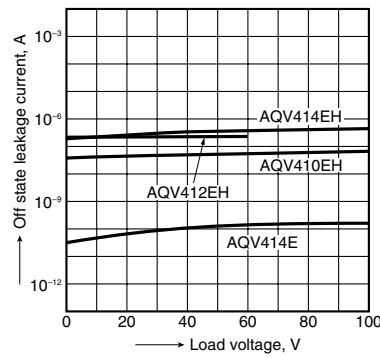

10. Operate (OFF) time vs. LED forward current characteristics

Measured portion: between terminals 4 and 6;
Load voltage: Max. (DC); Continuous load current: Max. (DC); Ambient temperature: 25°C 77°F

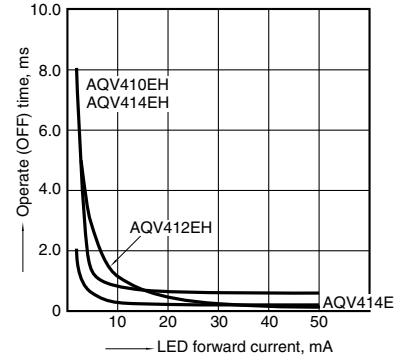

11. Reverse (ON) time vs. LED forward current characteristics

Measured portion: between terminals 4 and 6;
Load voltage: Max. (DC); Continuous load current: Max. (DC); Ambient temperature: 25°C 77°F

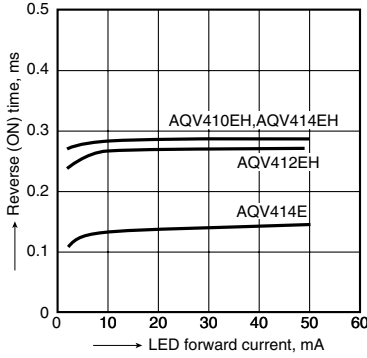

12. Output capacitance vs. applied voltage characteristics

Measured portion: between terminals 4 and 6;
Frequency: 1 MHz;
Ambient temperature: 25°C 77°F

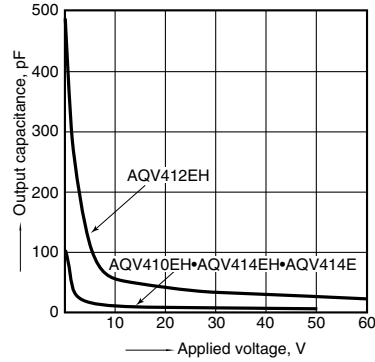

Mouser Electronics

Authorized Distributor

Click to View Pricing, Inventory, Delivery & Lifecycle Information:

[Panasonic:](#)

[AQV410EHAZ](#) [AQV414EHAX](#)