

DO NOT SCALE FROM THIS PRINT

BSH-XXX-01-X-D-XX-XX

**No OF POSITIONS**  
 -030, -40, -050, -060, -090,  
 \*\*120, \*\*150, \*-180  
 (PER ROW)  
 \*\*= SEE NOTE 10

**OPTION**  
 -TR: TAPE & REEL  
 (120 POSITION MAX)

**LEAD STYLE**  
 -01: .1280 [3.25]

**OPTION**  
 -A: ALIGNMENT PINS  
 (USE BSH-XXX-01-D-A)  
 -LC: LOCKING CLIPS  
 (USE LC-08-TM-01) (SEE NOTE 13)

**ROW SPECIFICATION**  
 -D: DOUBLE (USE BSH-XXX-01-D)

**PLATING SPECIFICATION**

-F: 3µ" FLASH SELECTIVE GOLD IN CONTACT AREA, MATTE TIN ON TAILS (SEE NOTES 7, 9 & 12)  
 -L: 10µ" LIGHT SELECTIVE GOLD IN CONTACT AREA, MATTE TIN ON TAILS (SEE NOTE 9 & 12)  
 -H: 30µ" HEAVY GOLD IN CONTACT AREA, 3µ" ON TAILS (SEE NOTE 9 & 12)  
 -C: 50µ" ELECTRO-POLISHED SELECTIVE IN CONTACT AREA, MATTE TIN ON TAILS (SEE NOTE 9 & 12)

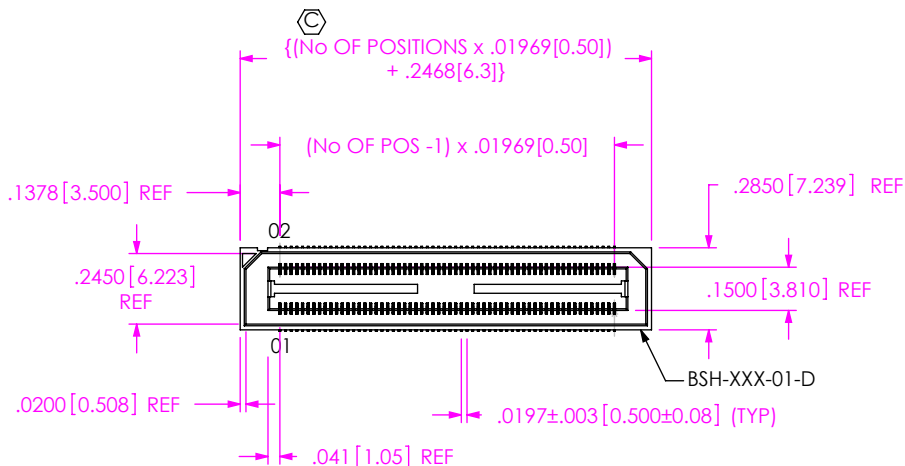

\* = NOT RELEASED FOR PRODUCTION

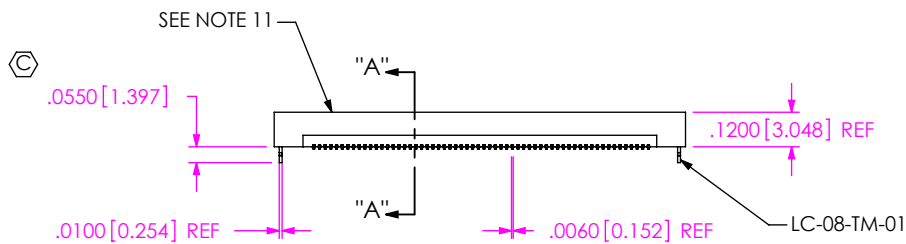

-LC: LOCKING CLIP OPTION SHOWN

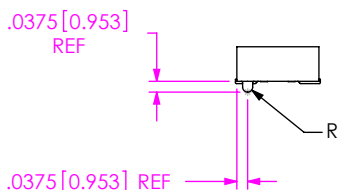

NOTES:

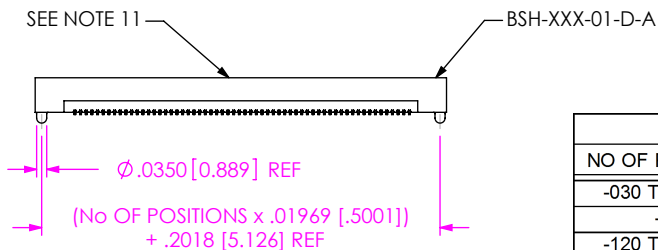

-A: ALIGNMENT PIN OPTION SHOWN

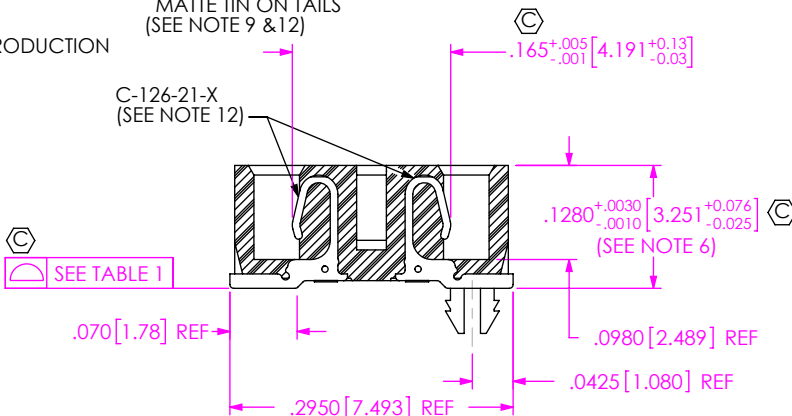

SECTION "A"- "A"  
 SCALE 5 : 1

NO OF POSITIONS	COPLANARITY
-030 THRU -060	.004 [0.10]
-090	.0055[0.14]
-120 THRU -180	.006 [0.15]

1. REPRESENTS A CRITICAL DIMENSION.
2. NOTE DELETED.
3. MAXIMUM BURR ALLOWANCE: .0015 [0.038]
4. MINIMUM PUSHOUT FORCE: 6 OZ
5. MAXIMUM ALLOWABLE BOW: .002 [0.05] INCH/INCH AFTER ASSEMBLY.
6. MAXIMUM VARIENCE OF .002[0.05]
7. -L PLATING CAN BE SUBSTITUED FOR -F PLATING.
8. ASP-65067-01 IS A BSH-050-01-L-D-A, WITH OR WITHOUT -TR.
9. MAY SUBSTITUTE C-126-01-X FOR C-126-21-X.
10. FOR NEWAPPLICATIONS REQUIRING THESE POSITIONS, PLEASE CONTACT SAMTEC INTERCONNECT PROCESSING GROUP.
11. SIDE WALLS MAY BE RIBBED TO AVOID BOW
12. -090, -120, -150 & \*-180 POSITION PARTS USE C-269-11-X. DO NOT SUB C-126-XX-X.
13. DUE TO THE HIGH AMOUNT OF INSERTION FORCE NEEDED, THE -LC OPTION IS NOT COMPATIBLE WITH AUTO PLACEMENT. SAMTEC RECOMMENDS MANUAL PLACEMENT FOR ALL ASSEMBLIES WITH THE -LC OPTION.

UNLESS OTHERWISE SPECIFIED, DIMENSIONS ARE IN INCHES. TOLERANCES ARE: DECIMALS ANGLES .XX: $\pm .01$ [0.25] .XXX: $\pm .005$ [0.13] .XXXX: $\pm .0020$ [0.050]	* PROPRIETARY NOTE THIS DOCUMENT CONTAINS CONFIDENTIAL AND PROPRIETARY INFORMATION AND ALL DESIGN, MANUFACTURING, REPRODUCTION, USE, PATENT RIGHTS AND SALES RIGHTS ARE EXPRESSLY RESERVED BY SAMTEC, INC. THIS DOCUMENT SHALL NOT BE DISCLOSED, IN WHOLE OR PART, TO ANY UNAUTHORIZED PERSON OR ENTITY NOR REPRODUCED, TRANSFERRED OR INCORPORATED IN ANY OTHER PROJECT IN ANY MANNER WITHOUT THE EXPRESS WRITTEN CONSENT OF SAMTEC, INC.	520 PARK EAST BLVD. NEW ALBANY, IN 47150 PHONE: 812-944-6733 FAX: 812-948-5047 e-Mail - info@SAMTEC.com code 55322
		DESCRIPTION: .75mm DOUBLE ROW SOCKET ASSEMBLY DWG. NO. <b>BSH-XXX-01-X-D-XX-XX</b> BY: DEAN P 06/08/1999 SHEET 1 OF 2
MATERIAL: DO NOT SCALE DRAWING SHEET SCALE: 3:2 FLAMMABILITY RATING: UL 94V-0 INSULATOR: BLACK LCP CONTACT: PHOS BRONZE		

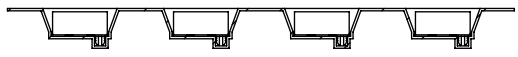
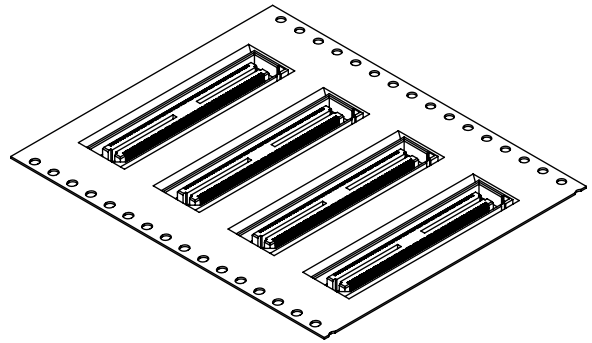
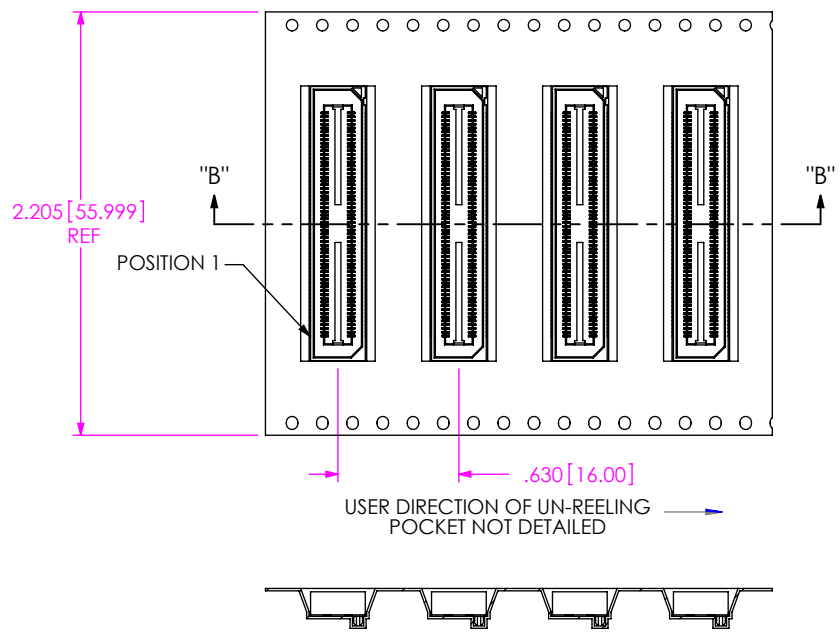

SECTION "B"- "B"  
SCALE 1 : 1

TAPE AND REEL PACKAGING VIEW

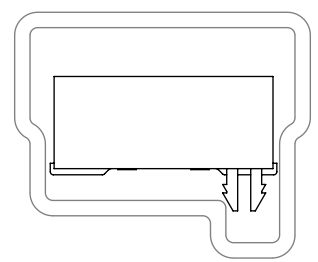

TUBE PACKAGING VIEW  
[PARTS TO HAVE POSITION #1 LOADED  
IN SAME DIRECTION AS ARROW]

TUBE: PT-1-24-02-78  
PLUG: TP-09

**PROPRIETARY NOTE**  
THIS DOCUMENT CONTAINS CONFIDENTIAL AND PROPRIETARY INFORMATION AND ALL DESIGN, MANUFACTURING, REPRODUCTION, USE, PATENT RIGHTS AND SALES RIGHTS ARE EXPRESSLY RESERVED BY SAMTEC, INC. THIS DOCUMENT SHALL NOT BE DISCLOSED, IN WHOLE OR PART, TO ANY UNAUTHORIZED PERSON OR ENTITY NOR REPRODUCED, TRANSFERRED OR INCORPORATED IN ANY OTHER PROJECT IN ANY MANNER WITHOUT THE EXPRESS WRITTEN CONSENT OF SAMTEC, INC.

DO NOT SCALE DRAWING  
SHEET SCALE: 1.5:1

520 PARK EAST BLVD. NEW ALBANY, IN 47150  
PHONE: 812-944-6733 FAX: 812-948-5047  
e-Mail info@SAMTEC.com code 55322

DESCRIPTION:  
.5mm DOUBLE ROW SOCKET ASSEMBLY  
DWG. NO. **BSH-XXX-01-X-D-XX-XX**

BY: DEAN P 06/08/1999 SHEET 2 OF 2