

RS485 click™

1. Introduction

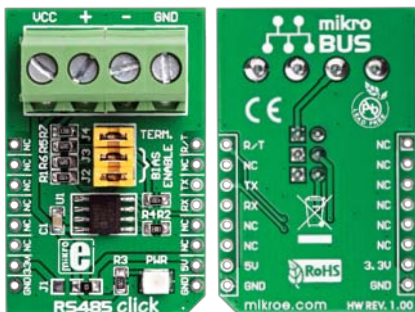

RS485 Click 5V is an accessory board in **mikroBus™** form factor. The on-board **ADM485** differential line transceiver is suitable for high speed bidirectional data communication on multipoint bus transmission lines. It is designed for balanced data transmission and complies with EIA standards RS-485 and RS-422. This transceiver features a differential line driver and differential line receiver. Board is set to use 5V power supply only.

2. Soldering the headers

Before using your click board, make sure to solder the provided 1x8 male headers to both sides of the board. Two 1x8 male headers are included with the board in the package.



1

2



Turn the board upside down, so that bottom side is facing you upwards. Place shorter parts of the header pins in the both soldering pad locations.

3

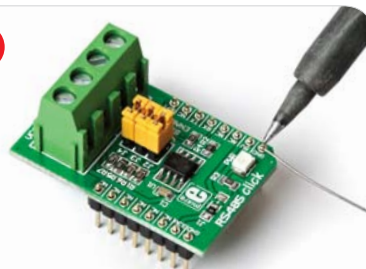

Turn the board upward again. Make sure to align the headers so that they are perpendicular to the board, then solder the pins carefully.



4. Using the board

There are four screw terminals on the board Those marked with "+" and "-" are RS485 differential high and differential low communication lines. We added two more terminals for VCC and GND reference if needed for further interfacing. Communication with the board is done using simple UART interface.

3. Plugging the board in

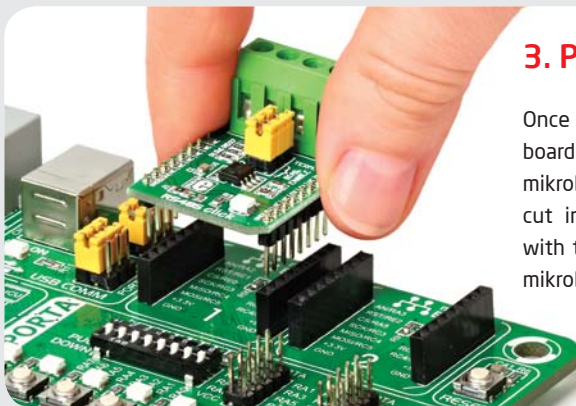

Once you have soldered the headers your board is ready to be placed into desired mikroBUS™ socket. Make sure to align the cut in the lower-right part of the board with the markings on the silkscreen at the mikroBUS™ socket. If all the pins are aligned correctly, push the board all the way into the socket.

click™
BOARD
www.mikroe.com



RS485 - 5V click Manual
ver. 1.00



0 100000 020098

5. RS485 click 5V Board Schematics

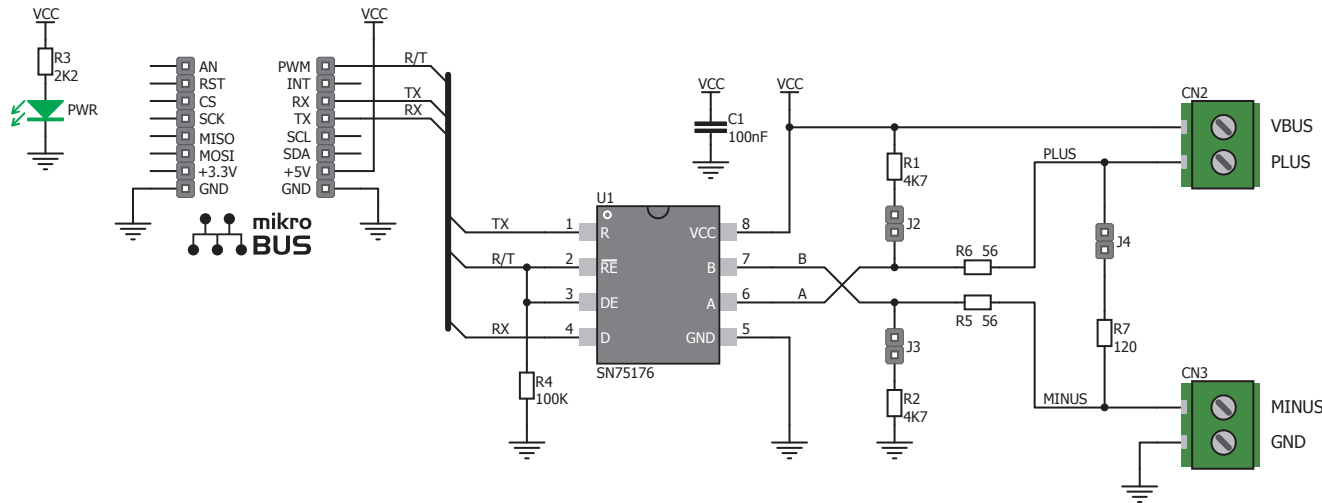

6. Node termination jumpers

1. If the board is the first node of RS485 network, all three jumpers **J2-J4** should be placed.
2. If the board is a node in the middle, all jumpers should be **removed**.
3. If the board is the last node of the RS485 network, place only **J4** termination jumper.

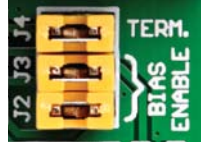

7. Code Examples

Once you have done all the necessary preparations, it's time to get your click board up and running. We have provided the examples for mikroC, mikroBasic and mikroPascal compilers on our **Libstock** website. Just download them and you are ready to start.



8. Support

MikroElektronika offers **Free Tech Support** (www.mikroe.com/esupport) until the end of product lifetime, so if something goes wrong, we are ready and willing to help!



Mouser Electronics

Authorized Distributor

Click to View Pricing, Inventory, Delivery & Lifecycle Information:

[MikroElektronika:](#)

[MIKROE-925](#)