

DUAL-CHANNEL, 16-BIT, 800 MSPS, 2x–8x INTERPOLATING DIGITAL-TO-ANALOG CONVERTER (DAC)

Check for Samples: [DAC5688](#)

FEATURES

- Dual, 16-Bit, 800 MSPS DACs
- Dual, 16-Bit, 250 MSPS CMOS Input Data
 - 16 Sample Input FIFO
 - Flexible input data bus options
- High Performance
 - 81 dBc ACLR WCDMA TM1 at 70 MHz
- 2x-32x Clock Multiplying PLL/VCO
- Selectable 2x–8x Interpolation Filters
 - Stop-band Attenuation > 80 dB
- Complex Mixer with 32-Bit NCO
- Digital Quadrature Modulator Correction
 - Gain, Phase and Offset Correction
- Digital Inverse SINC Filter
- 3- or 4-Wire Serial Control Interface
- On Chip 1.2-V Reference
- Differential Scalable Output: 2 to 20 mA
- Package: 64-pin 9x9mm QFN

APPLICATIONS

- Cellular Base Stations
- Broadband Wireless Access (BWA)
- WiMAX 802.16
- Fixed Wireless Backhaul
- Cable Modem Termination System (CMTS)

DESCRIPTION

The DAC5688 is a dual-channel 16-bit 800 MSPS digital-to-analog converter (DAC) with dual CMOS digital data bus, integrated 2x-8x interpolation filters, a fine frequency mixer with 32-bit complex numerically controlled oscillator (NCO), on-board clock multiplier, IQ compensation, and internal voltage reference. Different modes of operation enable or bypass various signal processing blocks. The DAC5688 offers superior linearity, noise, crosstalk and PLL phase noise performance.

The DAC5688 dual CMOS data bus provides 250 MSPS input data transfer per DAC channel. Several input data options are available: dual-bus data, single-bus interleaved data, even and odd multiplexing at half-rate, and an input FIFO with either external or internal clock to ease interface timing. Input data can be interpolated 2x, 4x or 8x by on-board digital interpolating FIR filters with over 80 dB of stop-band attenuation.

The DAC5688 allows both complex or real output. An optional 32-bit NCO/mixer in complex mode provides frequency upconversion and the dual DAC output produces a complex Hilbert Transform pair. A digital Inverse SINC filter compensates for natural DAC $\sin(x)/x$ frequency roll-off. The digital Quadrature Modulator Correction (QMC) feature allows IQ compensation of phase, gain and offset to maximize sideband rejection and minimize LO feed-through of an external quadrature modulator performing the final single sideband RF up-conversion.

The DAC5688 is pin compatible with the DAC5689 which does not include a clock-multiplying PLL. The DAC5688 is characterized for operation over the industrial temperature range of -40°C to 85°C and is available in a 64-pin 9x9mm QFN package.

ORDERING INFORMATION⁽¹⁾

Order Code $T_A = -40^{\circ}\text{C}$ to 85°C	Package Qty Tape and Reel Format	Package Drawing/Type ⁽²⁾ ⁽³⁾
DAC5688IRGCT	250	RGC / 64QFN Quad Flatpack No-Lead
DAC5688IRGCR	2000	

(1) For the most current package and ordering information, see the Package Option Addendum at the end of this document, or see the TI website at www.ti.com.

(2) Thermal Pad Size: 7,4 mm x 7,4 mm

(3) MSL Peak Temperature: Level-3-260C-168 HR



Please be aware that an important notice concerning availability, standard warranty, and use in critical applications of Texas Instruments semiconductor products and disclaimers thereto appears at the end of this data sheet.



This integrated circuit can be damaged by ESD. Texas Instruments recommends that all integrated circuits be handled with appropriate precautions. Failure to observe proper handling and installation procedures can cause damage.

ESD damage can range from subtle performance degradation to complete device failure. Precision integrated circuits may be more susceptible to damage because very small parametric changes could cause the device not to meet its published specifications.

FUNCTIONAL BLOCK DIAGRAM

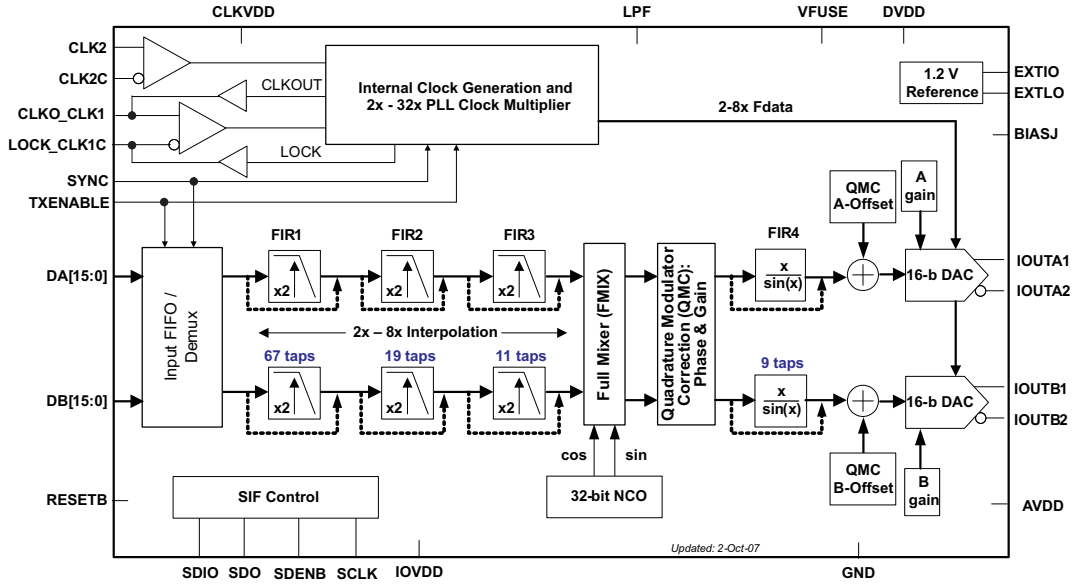

PINOUT

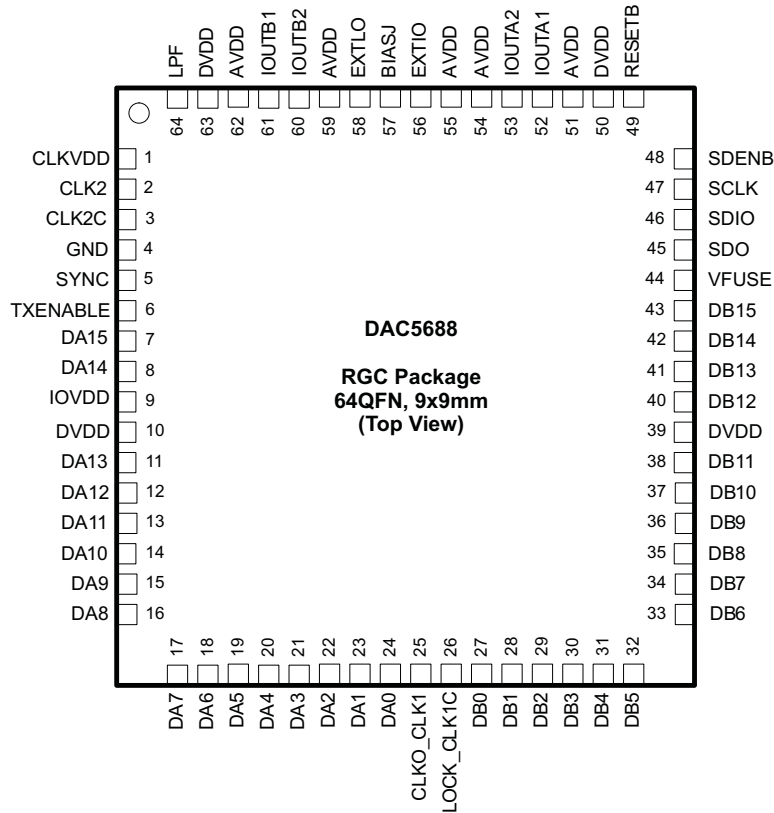

PIN FUNCTIONS

PIN		I/O	DESCRIPTION
NAME	NO.		
AVDD	51, 54, 55, 59, 62	I	Analog supply voltage. (3.3V)
BIASJ	57	O	Full-scale output current bias. For 20mA full-scale output current, connect a 960 Ω resistor to GND.
CLK2	2	I	With the clock multiplier PLL enabled, CLK2 provides lower frequency reference clock. If the PLL is disabled, CLK2 directly provides clock for DAC up to 800 MHz.
CLK2C	3	I	Complementary CLK2 input.
CLKO_CLK1	25	I/O	In Dual Clock Modes, provides lower frequency input clock (CLK1). Optionally provides clock (CLKO) output for data bus. Internal pull-down.
LOCK_CLK1C	26	I/O	Complementary CLK1 signal if configured as a differential input. In PLL mode, optionally outputs PLL lock status. Internal pull-down.
CLKVDD	1	I	Internal clock buffer supply voltage. (1.8V) It is recommended to isolate this supply from DVDD.
DA[15..0]	7, 8, 11–24	I	A-Channel Data Bits 0 through 15. DA15 is most significant data bit (MSB) – pin 7 DA0 is least significant data bit (LSB) – pin 24 Internal pull-down. The order of bus can be reversed via CONFIG4 reva bit.
DB[15..0]	40–43, 27–38	I	B-Channel Data Bits 0 through 15. DB15 is most significant data bit (MSB) – pin 43 DB0 is least significant data bit (LSB) – pin 27 Internal pull-down. The order of bus can be reversed via CONFIG4 revb bit.
DVDD	10, 39, 50, 63	I	Digital supply voltage. (1.8V) For best performance it is recommended to isolate pins 10 and 39 from all other 1.8V supplies.
EXTIO	56	I/O	Used as external reference input when internal reference is disabled (i.e., EXTLO connected to AVDD). Used as internal reference output when EXTLO = GND, requires a 0.1µF decoupling capacitor to GND when used as reference output
EXTLO	58	O	Connect to GND for internal reference, or AVDD for external reference.
GND	4, Thermal Pad	I	Pin 4 and the Thermal Pad located on the bottom of the QFN package is ground for AVDD, DVDD and IOVDD supplies.
IOUTA1	52	O	A-Channel DAC current output. An offset binary data pattern of 0x0000 at the DAC input results in a full scale current sink and the least positive voltage on the IOUTA1 pin. Similarly, a 0xFFFF data input results in a 0 mA current sink and the most positive voltage on the IOUTA1 pin. In single DAC mode, outputs appear on the IOUTA1/A2 pair only.
IOUTA2	53	O	A-Channel DAC complementary current output. The IOUTA2 has the opposite behavior of the IOUTA1 described above. An input data value of 0x0000 results in a 0mA sink and the most positive voltage on the IOUTA2 pin.
IOUTB1	61	O	B-Channel DAC current output. Refer to IOUTA1 description above.
IOUTB2	60	O	B-Channel DAC complementary current output. Refer to IOUTA2 description above.
IOVDD	9	I	3.3V supply voltage for all digital I/O. Note: This supply input should remain at 3.3V regardless of the 1.8V or 3.3V selectable digital input switching thresholds via CONFIG26 io_1p8_3p3 .
LPF	64	I	PLL loop filter connection. If not using the clock multiplying PLL, leave the LPF pin open. Set PLL_sleep and clear PLL_ena control bits for reduced power dissipation.
SYNC	5	I	Optional SYNC input for internal clock dividers, FIFO, NCO and QMC blocks. Internal pull-down.
RESETB	49	I	Resets the chip when low. Internal pull-up.
SCLK	47	I	Serial interface clock. Internal pull-down.
SDENB	48	I	Active low serial data enable, always an input to the DAC5688. Internal pull-up.
SDIO	46	I/O	Bi-directional serial data in 3-pin mode (default). In 4-pin interface mode (CONFIG5 sif4), the SDIO pin is an input only. Internal pull-down.
SDO	45	O	Uni-directional serial interface data in 4-pin mode (CONFIG5 sif4). The SDO pin is tri-stated in 3-pin interface mode (default). Internal pull-down.
TXENABLE	6	I	Transmit enable input. Internal pull-down. TXENABLE has two purposes. In all modes, TXENABLE must be high for the DATA to the DAC to be enabled. When TXENABLE is low, the digital logic section is forced to all 0, and any input data is ignored. In interleaved data mode, TXENABLE can be used to synchronize the data to channels A and B. The first A-channels sample should be aligned with the rising edge of TXENABLE.
VFUSE	44	I	Digital supply voltage. (1.8V) This supply pin is also used for factory fuse programming. Connect to DVDD pins for normal operation.

ABSOLUTE MAXIMUM RATINGS

over operating free-air temperature range (unless otherwise noted)⁽¹⁾

		VALUE	UNIT
Supply Voltage Range	DVDD ⁽²⁾	–0.5 to 2.3	V
	VFUSE ⁽²⁾	–0.5 to 2.3	V
	CLKVDD ⁽²⁾	–0.5 to 2.3	V
	AVDD ⁽²⁾	–0.5 to 4	V
	IOVDD ⁽²⁾	–0.5 to 4	V
Supply Voltage Range	AVDD to DVDD	–2 to 2.6	V
	CLKVDD to DVDD	–0.5 to 0.5	V
	IOVDD to AVDD	–0.5 to 0.5	V
	CLK2, CLK2C ⁽²⁾	–0.5 to CLKVDD + 0.5	V
	CLKO_CLK1, LOCK_CLK1C, SLEEP, TXENABLE ⁽²⁾	–0.5 to IOVDD + 0.5	V
	DA[15..0], DB[15..0] ⁽²⁾	–0.5 to IOVDD + 0.5	V
	SDO, SDIO, SCLK, SDENB, RESETB ⁽²⁾	–0.5 to IOVDD + 0.5	V
	IOUTA1/B1, IOUTA2/B2 ⁽²⁾	–0.5 to AVDD + 0.5	V
	LPF, EXTIO, EXTLO, BIASJ ⁽²⁾	–0.5 to AVDD + 0.5	V
Peak input current (any input)		20 mA	mA
Peak total input current (all inputs)		–30 mA	mA
Operating free-air temperature range, T _A : DAC5688I		–40 to 85	°C
Storage temperature range		–65 to 150	°C

(1) Stresses beyond those listed under *absolute maximum ratings* may cause permanent damage to the device. These are stress ratings only, and functional operation of these or any other conditions beyond those indicated under *recommended operating conditions* is not implied. Exposure to absolute-maximum-rated conditions for extended periods may affect device reliability.

(2) Measured with respect to GND.

THERMAL INFORMATION

THERMAL CONDUCTIVITY		DAC5688	UNITS
		64ld QFN	
T _J	Maximum junction temperature ⁽¹⁾⁽²⁾	125	°C
θ _{JA}	Theta junction-to-ambient thermal resistance (still air)	22	°C/W
	Theta junction-to-ambient thermal resistance (200 lfm)	15	
ψ _{JT}	Psi junction-to-top of package characterization parameter	0.2	
θ _{JB}	Theta junction-to-board characterization parameter	3.5	

(1) Air flow or heat sinking reduces θ_{JA} and may be required for sustained operation at 85°C under maximum operating conditions.

(2) It is strongly recommended to solder the device thermal pad to the board ground plane.

ELECTRICAL CHARACTERISTICS (DC SPECIFICATIONS)

 over recommended operating free-air temperature range, AVDD, IOVDD = 3.3 V, DVDD, CLKVDD = 1.8 V, IOU_{FS} = 20 mA

PARAMETER		TEST CONDITIONS	MIN	TYP	MAX	UNIT
RESOLUTION			16			Bits
DC ACCURACY						
INL	Integral nonlinearity	1 LSB = IOU _{FS} /2 ¹⁶		±4		LSB
DNL	Differential nonlinearity			±2		LSB
ANALOG OUTPUT						
Coarse gain linearity				± 0.04		LSB
Offset error mid code offset				0.01		%FSR
Gain error		With external reference		1		%FSR
		With internal reference		0.7		%FSR
Gain mismatch		With internal reference, dual DAC mode	-2		2	%FSR
Minimum full scale output current		Nominal full-scale current, IOU _{FS} = 16 × IBIAS current.		2		mA
Maximum full scale output current				20		
Output compliance range ⁽¹⁾		IOU _{FS} = 20 mA	AVDD - 0.5V		AVDD + 0.5V	V
Output resistance				300		kΩ
Output capacitance				5		pF
REFERENCE OUTPUT						
V _{REF}	Reference output voltage	Internal Reference Mode	1.14	1.2	1.26	V
	Reference output current ⁽²⁾			100		
REFERENCE INPUT						
V _{EXTIO}	Input voltage range	External Reference Mode	0.1		1.25	V
	Input resistance				1	
Small signal bandwidth		CONFIG26: isbiaslpf_a and isbiaslpf_b = 0		95		kHz
		CONFIG26: isbiaslpf_a and isbiaslpf_b = 1		472		
Input capacitance				100		pF
TEMPERATURE COEFFICIENTS						
Offset drift				±1		ppm of FSR/°C
Gain drift		With external reference		±15		
		With internal reference		±30		
Reference voltage drift				±8		ppm/°C
POWER SUPPLY						
AVDD, IOVDD			3.0	3.3	3.6	V
DVDD, CLKVDD			1.7	1.8	1.9	V
PSRR	Power supply rejection ratio			±0.2		%FSR/V
P	AVDD + IOVDD current, 3.3V	Mode 1: x8 Interp, PLL on, QMC = off, ISINC = off, DAC A+B on, F _{IN} = 5 MHz Tone, NCO = 145 MHz, F _{OUT} = 150 MHz, F _{DAC} = 500 MHz		150		mA
	DVDD + CLKVDD current, 1.8V			450		mA
	Power Dissipation			1300		mW
	AVDD + IOVDD current, 3.3V	Mode 2: x8 Interp, PLL off, QMC = on, ISINC = on, DAC A+B on, F _{IN} = 5 MHz Tone, NCO = 91 MHz, F _{OUT} = 96 MHz, F _{DAC} = 614.4 MHz		140		mA
	DVDD + CLKVDD current, 1.8V			520		mA
	Power Dissipation			1400		mW
	AVDD + IOVDD current, 3.3V	Mode 3 (Max): x4 Interp, PLL on, QMC = on, ISINC = on, DAC A+B on, F _{IN} = 5 MHz Tone, NCO = 135 MHz, F _{OUT} = 140 MHz, F _{DAC} = 800 MHz		150		mA
	DVDD + CLKVDD current, 1.8V			700		mA
	Power Dissipation			1750	1950	mW
	AVDD + IOVDD current, 3.3V	Mode 4 (Sleep): x8 Interp, PLL off, QMC = off, ISINC = off, DAC A+B off, F _{IN} = 5 MHz Tone, NCO = off, F _{OUT} = off, F _{DAC} = 800 MHz,		12		mA
	DVDD + CLKVDD current, 1.8V			15		mA
	Power Dissipation			65	100	mW

- (1) The upper limit of the output compliance is determined by the CMOS process. Exceeding this limit may result in transistor breakdown, resulting in reduced reliability of the DAC5688 device. The lower limit of the output compliance is determined by the load resistors and full-scale output current. Exceeding the upper limit adversely affects distortion performance and integral nonlinearity.
- (2) Use an external buffer amplifier with high impedance input to drive any external load.

ELECTRICAL CHARACTERISTICS (AC SPECIFICATIONS)

Over recommended operating free-air temperature range, AVDD, IOVDD = 3.3 V, DVDD, CLKVDD = 1.8 V, IOUT_{FS} = 20 mA

PARAMETER		TEST CONDITIONS	MIN	TYP	MAX	UNIT
ANALOG OUTPUT⁽¹⁾						
f _{DAC}	Maximum output update rate		800			MSPS
t _{s(DAC)}	Output settling time to 0.1%	Transition: Code 0x0000 to 0xFFFF		10.4		ns
t _{pd}	Output propagation delay	DAC outputs are updated on falling edge of DAC clock. Does not include Digital Latency (see below).		2		ns
t _{r(IOUT)}	Output rise time	10% to 90%		220		ps
t _{f(IOUT)}	Output fall time	90% to 10%		220		ps
Digital Latency		No Interp, NCO off, QMC off, ISINC = off		109		DAC clock cycles
		x2 Interpolation, NCO off, QMC off, ISINC = off		172		
		x4 Interpolation, NCO off, QMC off, ISINC = off		276		
		x8 Interpolation, NCO off, QMC off, ISINC = off		488		
		x8 Interpolation, NCO on, QMC off, ISINC = off		512		
		x8 Interpolation, NCO on, QMC on, ISINC = off		528		
		x8 Interpolation, NCO on, QMC on, ISINC = on		548		
AC PERFORMANCE⁽²⁾						
SFDR	Spurious free dynamic range	x4 Interp, PLL off, CLK2 = 800 MHz, DAC A+B on, 0 dBFS Single tone, F _{OUT} = F _{IN} First Nyquist Zone < f _{DATA} /2	F _{OUT} = 10.1 MHz	83		dBc
			F _{OUT} = 20.1 MHz	79		
SNR	Signal-to-Noise Ratio	x4 Interp, PLL off, CLK2 = 800 MHz, DAC A+B on, 0 dBFS Single tone, F _{IN} = 10.1 MHz, F _{OUT} = F _{IN} + NCO	NCO= 10 MHz, F _{OUT} = 20.1 MHz	72		dBc
			NCO= 60 MHz, F _{OUT} = 70.1 MHz	68		
			NCO= 140 MHz, F _{OUT} = 150.1 MHz	64		
			NCO= 290 MHz, F _{OUT} = 300.1 MHz	57		
IMD3	Third-order Two-Tone intermodulation (Each tone at -6 dBFS)	x4 Interp, PLL off, CLK2 = 800 MHz, DAC A+B on, F _{IN} = 10.5 and 11.5 MHz, F _{OUT} = F _{IN} + NCO	NCO= 40 MHz, F _{OUT} = 51±0.5 MHz	85		dBc
			NCO= 60 MHz, F _{OUT} = 71±0.5 MHz	83		
			NCO= 130 MHz, F _{OUT} = 141±0.5 MHz	74		
IMD	Four-tone Intermodulation to Nyquist (Each tone at -12 dBFS)	x4 Interp, PLL off, CLK2 = 800 MHz, DAC A+B on, F _{IN} = 9.8, 10.4, 11.6 and 12.2 MHz (600kHz spacing), NCO = 129 MHz, F _{OUT} = F _{IN} + NCO = 140±1.2 MHz		73		dBc
ACLR ⁽³⁾	Adjacent Channel Leakage Ratio	x8 Interp, PLL off, CLK2 = 737.28 MHz, DAC A+B on, F _{IN} = 23.04 MHz, NCO = off	Single Carrier, F _{OUT} = 23.04 MHz	81		dBc
			Single Carrier, F _{OUT} = 70MHz	81		
			Single Carrier, F _{OUT} = 140MHz	78		
			Four Carrier, F _{OUT} = 140MHz	70		
Noise Floor, Noise Spectral Density (NSD) ⁽³⁾		x8 Interp, PLL off, CLK2 = 737.28 MHz, DAC A+B on, F _{IN} = F _{OUT} = Baseband I/Q, 50 MHz offset, 1 MHz BW	Single Carrier Noise Floor	101		dBm
			Single Carrier NSD in 1 MHz BW	161		dBm/Hz
			Four Carrier Noise Floor	101		dBm
			Four Carrier NSD in 1 MHz BW	161		dBm/Hz

- (1) Measured differential across IOUTA1 and IOUTA2 or IOUTB1 and IOUTB2 with 25 Ω each to AVDD.
- (2) 4:1 transformer output termination, 50Ω doubly terminated load
- (3) W-CDMA with 3.84 MHz BW, 5-MHz spacing, centered at IF. TESTMODEL 1, 10 ms

ELECTRICAL CHARACTERISTICS (DIGITAL SPECIFICATIONS)

Over recommended operating free-air temperature range, AVDD, IOVDD = 3.3V, DVDD, CLKVDD = 1.8V.

PARAMETER		TEST CONDITIONS	MIN	TYP	MAX	UNIT
CMOS INTERFACE: SDO, SDIO, SCLK, SDENB, RESETB, DA[15:0], DB[15:0], SYNC, TXENABLE, CLKO_CLK1, LOCK_CLK1C						
V _{IH}	High-level input voltage	CONFIG26 io_1p8_3p3 = 0 (3.3V levels)	2.30			V
		CONFIG26 io_1p8_3p3 = 1 (1.8V levels)	1.25			
V _{IL}	Low-level input voltage	CONFIG26 io_1p8_3p3 = 0 (3.3V levels)			1.00	V
		CONFIG26 io_1p8_3p3 = 1 (1.8V levels)			0.54	
I _{IH}	High-level input current			±20		μA
I _{IL}	Low-level input current			±20		μA
C _I	CMOS Input capacitance			2		pF
V _{OH}	SDO, SDIO	I _{LOAD} = -100 μA	IOVDD - 0.2			V
	SDO, SDIO	I _{LOAD} = -2 mA	0.8 × IOVDD			
V _{OL}	SDO, SDIO	I _{LOAD} = 100 μA			0.2	V
	SDO, SDIO	I _{LOAD} = 2 mA			0.5	
	Input data rate		0		250	MSPS
t _s (SDENB)	Setup time, SDENB to rising edge of SCLK		20			ns
t _s (SDIO)	Setup time, SDIO valid to rising edge of SCLK		10			ns
t _h (SDIO)	Hold time, SDIO valid to rising edge of SCLK		5			ns
t _{SCLK}	Period of SCLK		100			ns
t _{SCLKH}	High time of SCLK		40			ns
t _{SCLKL}	Low time of SCLK		40			ns
t _d (Data)	Data output delay after falling edge of SCLK			10		ns
t _{RESET}	Minimum RESETB pulse width			25		ns
TIMING PARALLEL DATA INPUT: (DUAL CLOCK and DUAL SYNCHRONOUS CLOCK MODES: Figure 32)						
t _s	Setup time	CLK1/C = input	1			ns
t _h	Hold time		1			ns
t _{align}	Max timing offset between CLK1 and CLK2 rising edges	DUAL SYNCHRONOUS BUS MODE only (Typical characteristic)	$\frac{1}{2f_{CLK2}} - 0.55$			ns
TIMING PARALLEL DATA INPUT (EXTERNAL CLOCK MODE: Figure 33 and PLL CLOCK MODE: Figure 34)						
t _s	Setup time	CLKO_CLK1 = input or output. Note: Delay time increases with higher capacitive loads.	1			ns
t _h	Hold time		1			ns
t _d (CLKO)	Delay time		4.5			ns
CLOCK INPUT (CLK2/CLK2C)						
	CLK2/C Duty cycle		40%		60%	
	CLK2/C Differential voltage ⁽¹⁾		0.4	1		V
	CLK2/C Input common mode		$\frac{2}{3} \times CLKVDD$			V
	CLK2C Input Frequency				800	MHz
CLOCK INPUT (CLK1/CLK1C)						
	CLK1/C Duty cycle		40%		60%	
	CLK1/C Differential voltage		0.4	1.0		V
	CLK1/C Input common mode		IOVDD / 2			V
	CLK1/C Input Frequency				250	MHz
CLOCK OUTPUT (CLKO)						
	CLKO Output Frequency ⁽²⁾	with 3pF load			160	MHz

(1) Driving the clock input with a differential voltage lower than 1V will result in degraded performance.

(2) Specified by design and simulation. Not production tested. It is recommended to buffer CLKO.

ELECTRICAL CHARACTERISTICS (DIGITAL SPECIFICATIONS)

Over recommended operating free-air temperature range, AVDD, IOVDD = 3.3V, DVDD, CLKVDD = 1.8V.

PARAMETER	TEST CONDITIONS	MIN	TYP	MAX	UNIT
PHASE LOCKED LOOP					
Phase noise at 600 kHz offset	100 MHz, 0-dBFS tone, f _{DATA} = 200 MSPS, CLK2/C = 200 MHz, PLL _m = '00111', PLL _n = '001', (M/N=4) PLL _{gain} = '11', PLL _{range} = '1000' (8) x4 Interpolation	-125			dBc/ Hz
Phase noise at 6 MHz offset		-146			
PLL/VCO Operating Frequency, Typical VCO Gain	PLL _{gain} = '00', PLL _{range} = '0000' (0)	140		270	MHz
			215		MHz/V
	PLL _{gain} = '01', PLL _{range} = '0001' (1)	270		440	MHz
			290		MHz/V
	PLL _{gain} = '01', PLL _{range} = '0010' (2)	370		490	MHz
			255		MHz/V
	PLL _{gain} = '01', PLL _{range} = '0011' (3)	450		530	MHz
			230		MHz/V
	PLL _{gain} = '10', PLL _{range} = '0100' (4)	530		650	MHz
			285		MHz/V
	PLL _{gain} = '10', PLL _{range} = '0101' (5)	600		680	MHz
			260		MHz/V
	PLL _{gain} = '10', PLL _{range} = '0110' (6)	660		720	MHz
			245		MHz/V
	PLL _{gain} = '10', PLL _{range} = '0111' (7)	710		750	MHz
			230		MHz/V
PLL _{gain} = '11', PLL _{range} = '1000' (8)	750		830	MHz	
		275		MHz/V	
PLL _{gain} = '11', PLL _{range} = '1001' (9)	800		860	MHz	
		260		MHz/V	
PLL _{gain} = '11', PLL _{range} = '1010' (A)	840		890	MHz	
		245		MHz/V	
PLL _{gain} = '11', PLL _{range} = '1011' (B)	880		910	MHz	
		235		MHz/V	
PFD Maximum Frequency			160		MHz

TYPICAL CHARACTERISTICS

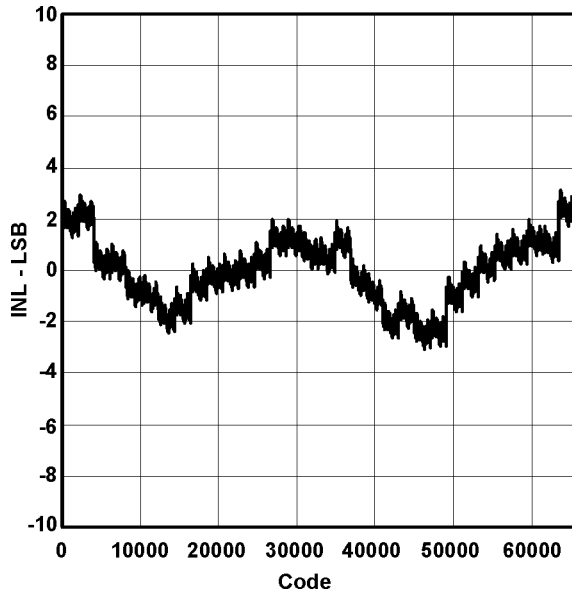

Figure 1. Integral Nonlinearity

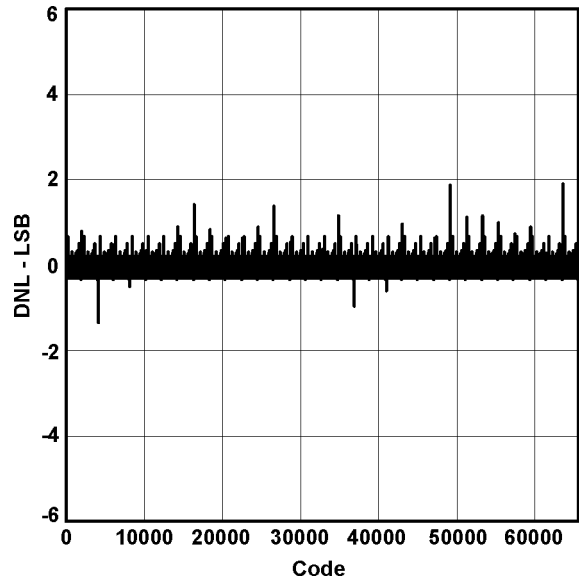

Figure 2. Differential Nonlinearity

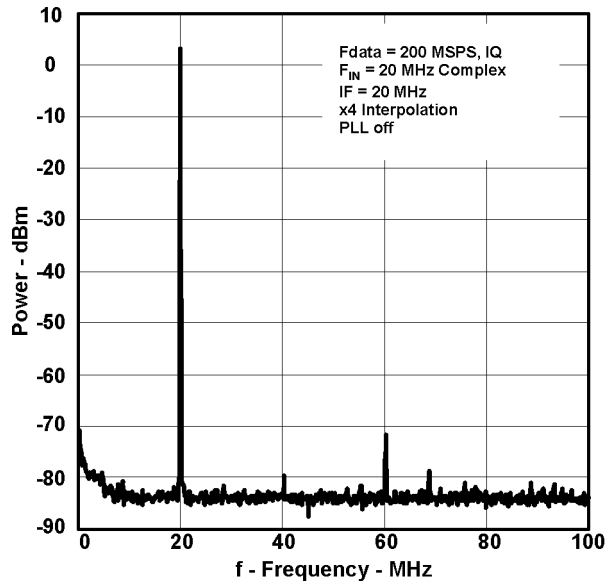

Figure 3. Single Tone Spectral Plot

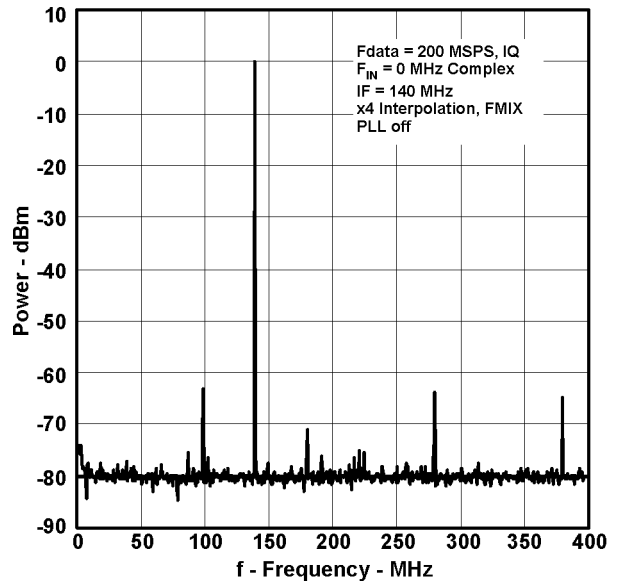

Figure 4. Single Tone Spectral Plot

TYPICAL CHARACTERISTICS (continued)

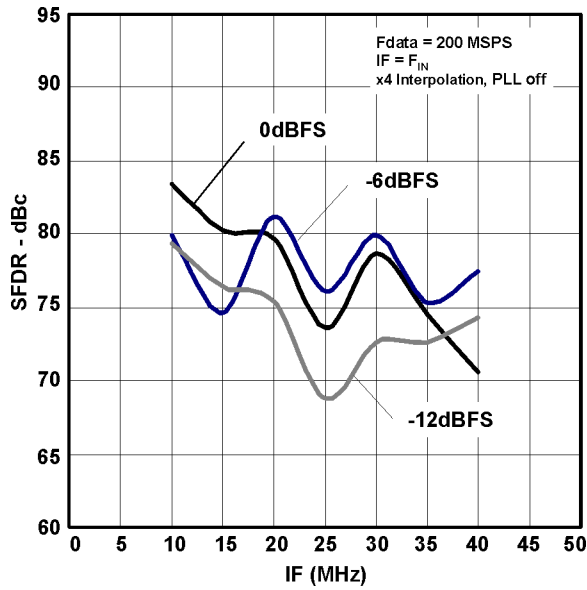

Figure 5. In-Band SFDR vs. Intermediate Frequency

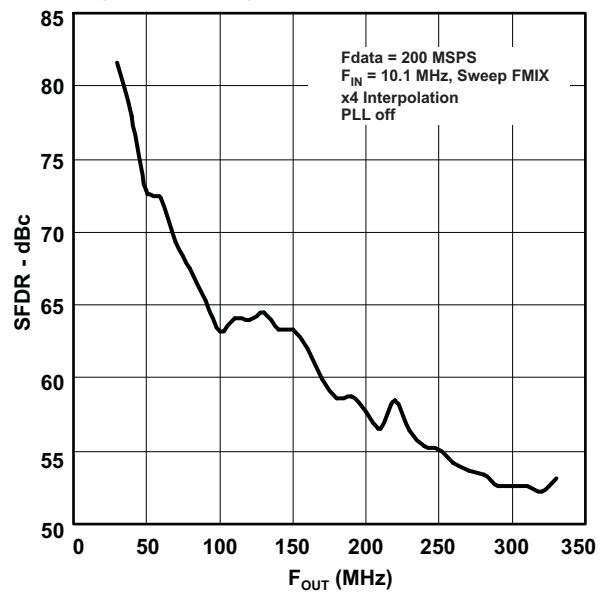

Figure 6. Out-Of-Band SFDR vs. Intermediate Frequency

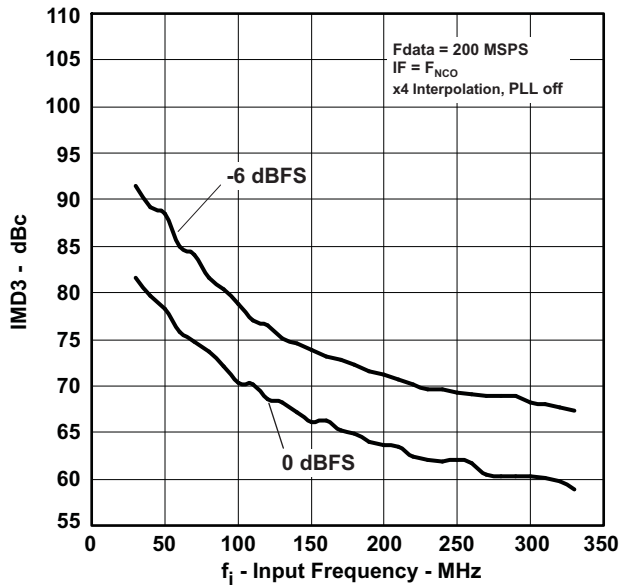

Figure 7. Two Tone IMD vs. Intermediate Frequency

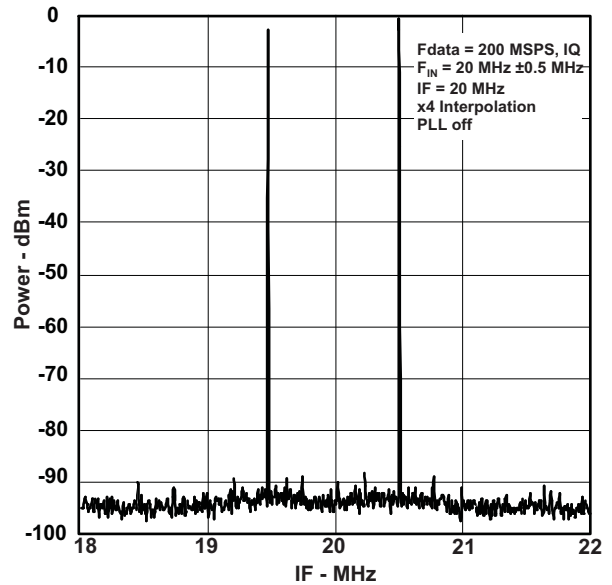

Figure 8. Two Tone IMD Spectral Plot

TYPICAL CHARACTERISTICS (continued)

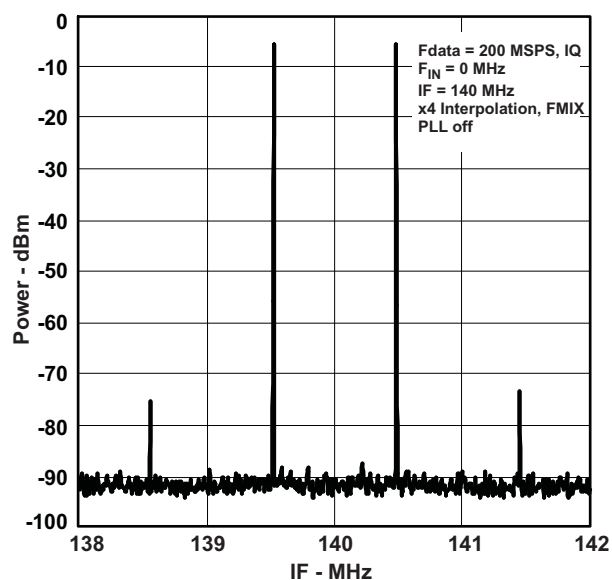

Figure 9. Two Tone IMD Spectral Plot

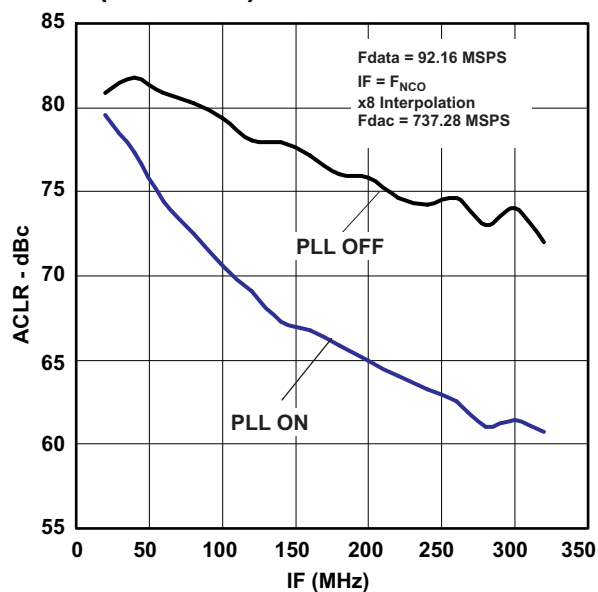

Figure 10. WCDMA ACLR vs Intermediate Frequency

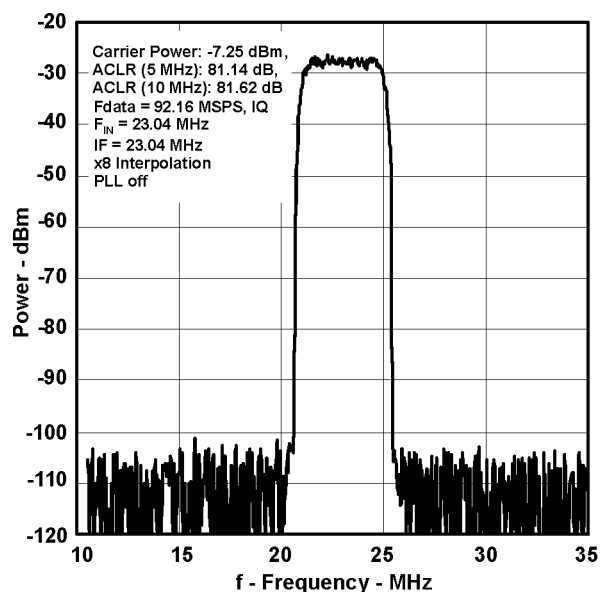

Figure 11. WCDMA TM1:Single Carrier, PLL Off

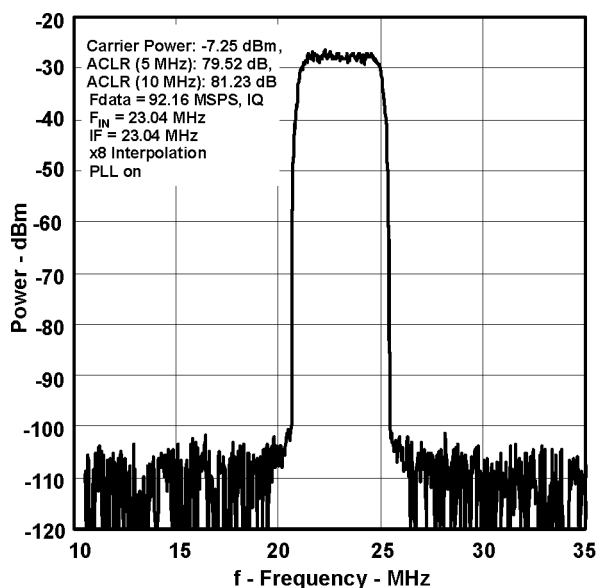

Figure 12. WCDMA TM1:Single Carrier, PLL On

TYPICAL CHARACTERISTICS (continued)

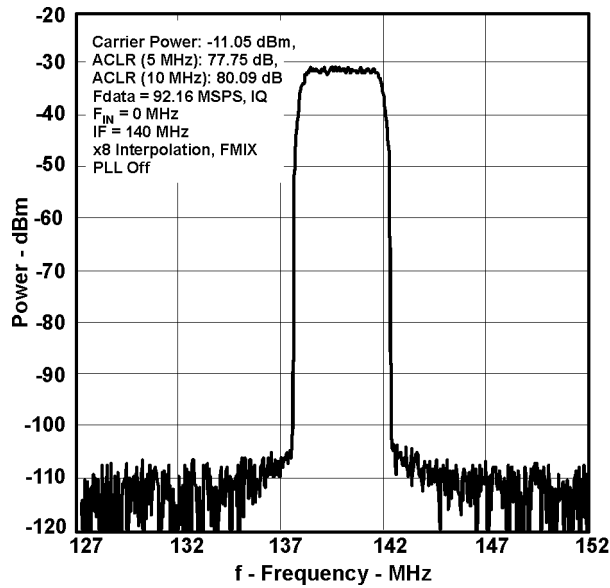

Figure 13. WCDMA TM1:Single Carrier, PLL Off

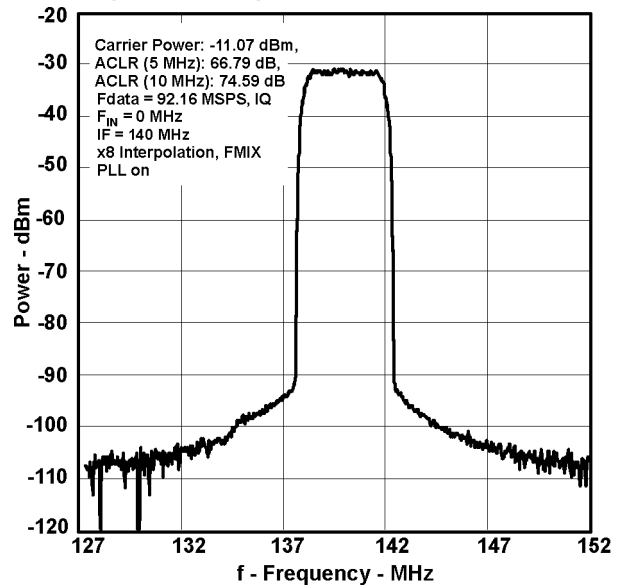

Figure 14. WCDMA TM1:Single Carrier, PLL On

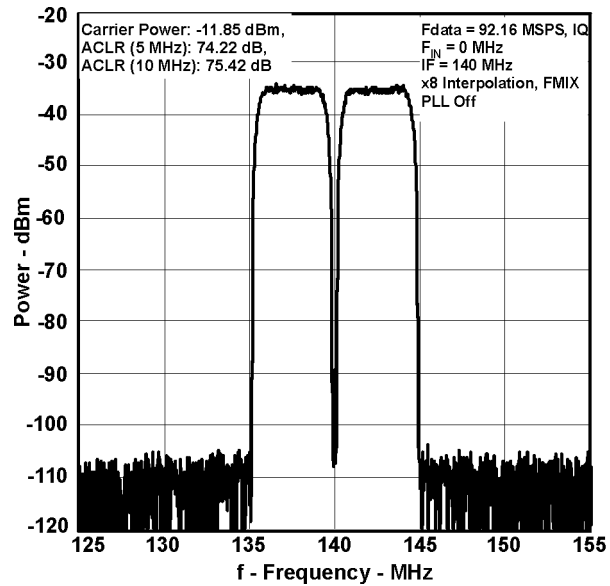

Figure 15. WCDMA TM1:Two Carriers, PLL Off

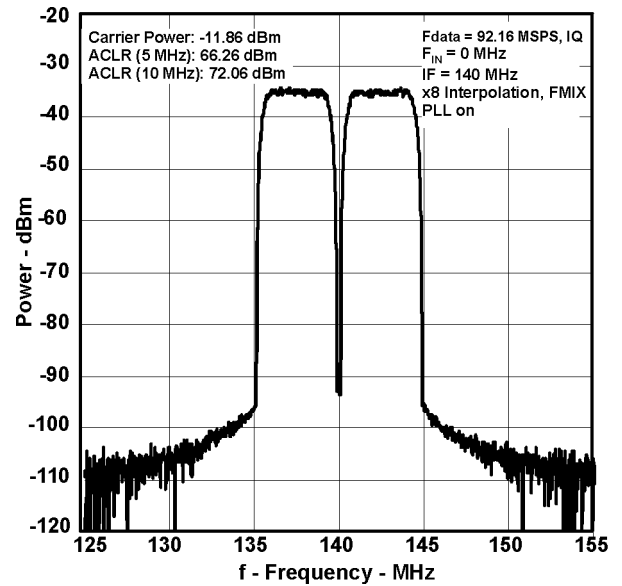

Figure 16. WCDMA TM1:Two Carriers, PLL On

TYPICAL CHARACTERISTICS (continued)

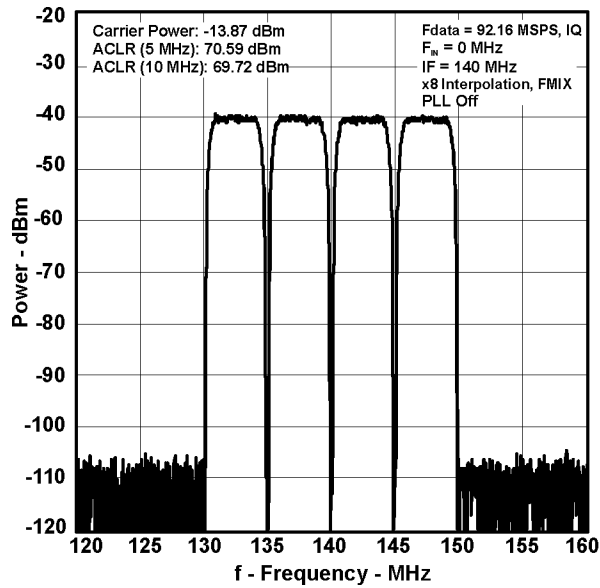

Figure 17. WCDMA TM1:Four Carriers, PLL Off

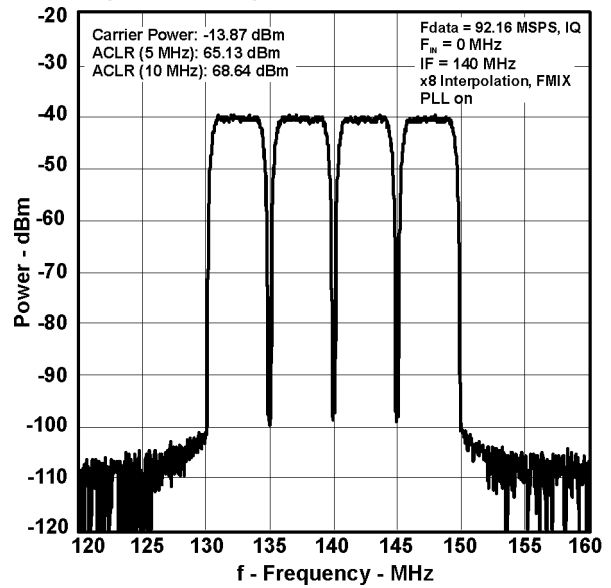

Figure 18. WCDMA TM1:Four Carriers, PLL On

TEST METHODOLOGY

Typical AC specifications were characterized with the DAC5688EVM. A sinusoidal master clock frequency is generated by an HP8665B signal generator which drives an Agilent 8133A pulse generator to generate a square wave output clock for the TSW3100 Pattern Generator and EVM input clock. On the EVM, the input clock is driven by an CDCM7005 clock distribution chip that is configured to simply buffer the external clock or divide it down for necessary test configurations.

The DAC5688 output is characterized with a Rohde and Schwarz FSU spectrum analyzer. For WCDMA signal characterization, it is important to use a spectrum analyzer with high IP3 and noise subtraction capability so that the spectrum analyzer does not limit the ACPR measurement.

DEFINITION OF SPECIFICATIONS

Adjacent Carrier Leakage Ratio (ACLR): Defined for a 3.84Mcps 3GPP W-CDMA input signal measured in a 3.84MHz bandwidth at a 5MHz offset from the carrier with a 12dB peak-to-average ratio.

Analog and Digital Power Supply Rejection Ratio (APSRR, DPSRR): Defined as the percentage error in the ratio of the delta IOUT and delta supply voltage normalized with respect to the ideal IOUT current.

Differential Nonlinearity (DNL): Defined as the variation in analog output associated with an ideal 1 LSB change in the digital input code.

Gain Drift: Defined as the maximum change in gain, in terms of ppm of full-scale range (FSR) per °C, from the value at ambient (25°C) to values over the full operating temperature range.

Gain Error: Defined as the percentage error (in FSR%) for the ratio between the measured full-scale output current and the ideal full-scale output current.

Integral Nonlinearity (INL): Defined as the maximum deviation of the actual analog output from the ideal output, determined by a straight line drawn from zero scale to full scale.

Intermodulation Distortion (IMD3, IMD): The two-tone IMD3 or four-tone IMD is defined as the ratio (in dBc) of the worst 3rd-order (or higher) intermodulation distortion product to either fundamental output tone.

Offset Drift: Defined as the maximum change in DC offset, in terms of ppm of full-scale range (FSR) per °C, from the value at ambient (25°C) to values over the full operating temperature range.

Offset Error: Defined as the percentage error (in FSR%) for the ratio between the measured mid-scale output current and the ideal mid-scale output current.

Output Compliance Range: Defined as the minimum and maximum allowable voltage at the output of the current-output DAC. Exceeding this limit may result reduced reliability of the device or adversely affecting distortion performance.

Reference Voltage Drift: Defined as the maximum change of the reference voltage in ppm per degree Celsius from value at ambient (25°C) to values over the full operating temperature range.

Spurious Free Dynamic Range (SFDR): Defined as the difference (in dBc) between the peak amplitude of the output signal and the peak spurious signal.

Signal to Noise Ratio (SNR): Defined as the ratio of the RMS value of the fundamental output signal to the RMS sum of all other spectral components below the Nyquist frequency, including noise, but excluding the first six harmonics and dc.

REGISTER DESCRIPTIONS

Table 1. Register Map

Name	Address	Default	(MSB) Bit 7	Bit 6	Bit 5	Bit 4	Bit 3	Bit 2	Bit 1	(LSB) Bit 0	
STATUS0	0x00	0x01	PLL_lock	unused	unused	device_ID(2:0)			version(1:0)		
CONFIG1	0x01	0x0B	inset_mode(1:0)		unused	synchr_clkin	twos	inv_inclk	interp_value(1:0)		
CONFIG2	0x02	0xE1	diffclk_ena	clk1_in_ena	clk1c_in_ena	clko_SE_hold	fir4_ena	qmc_offset_ena	qmc_corr_ena	mixer_ena	
CONFIG3	0x03	0x00	diffclk_dly(1:0)		clko_dly(1:0)		reserved				
CONFIG4	0x04	0x00	ser_dac_data_ena	output_delay(1:0)		B_equals_A	A_equals_B	unused	reva	revb	
CONFIG5	0x05	0x22	sif4	sif_sync_sig	clkdiv_sync_ena	clkdiv_sync_sel	reserved	clkdiv_shift	mixer_gain	unused	
CONFIG6	0x06	0x00	phaseoffset(7:0)								
CONFIG7	0x07	0x00	phaseoffset(15:8)								
CONFIG8	0x08	0x00	phaseadd(7:0)								
CONFIG9	0x09	0x00	phaseadd(15:8)								
CONFIG10	0x0A	0x00	phaseadd(23:16)								
CONFIG11	0x0B	0x00	phaseadd(31:24)								
CONFIG12	0x0C	0x00	qmc_gaina(7:0)								
CONFIG13	0x0D	0x00	qmc_gainb(7:0)								
CONFIG14	0x0E	0x00	qmc_phase(7:0)								
CONFIG15	0x0F	0x24	qmc_phase(9:8)		qmc_gaina(10:8)			qmc_gainb(10:8)			
CONFIG16	0x10	0x00	qmc_offseta(7:0)								
CONFIG17	0x11	0x00	qmc_offsetb(7:0)								
CONFIG18	0x12	0x00	qmc_offseta(12:8)						unused	unused	unused
CONFIG19	0x13	0x00	qmc_offsetb(12:8)						unused	unused	unused
CONFIG20	0x14	0x00	ser_dac_data(7:0)								
CONFIG21	0x15	0x00	ser_dac_data(15:8)								
CONFIG22	0x16	0x15	nco_sel(1:0)		nco_reg_sel(1:0)		qmcrr_reg_sel(1:0)		qmcrr_offset_reg_sel(1:0)		
CONFIG23	0x17	0x15	unused	unused	fifo_sel(2:0)		aflag_sel		unused	unused	
CONFIG24	0x18	0x80	fifo_sync_strt(3:0)			unused		unused	unused	unused	
CONFIG25	0x19	0x00	unused	unused	unused	unused	unused	unused	unused	unused	
CONFIG26	0x1A	0x0D	io_1p8_3p3	unused	sleepb	sleepa	isbiaslpf_a	isbiaslpf_b	PLL_sleep	PLL_ena	
CONFIG27	0x1B	0xFF	coarse_daca(3:0)				coarse_dacb(3:0)				
CONFIG28	0x1C	0x00	reserved								
CONFIG29	0x1D	0x00	PLL_m(4:0)					PLL_n(2:0)			
CONFIG30	0x1E	0x00	PLL_LPF_reset	VCO_div2	PLL_gain(1:0)		PLL_range(3:0)				

Register name: STATUS0 - Address: 0x00, Default 0x01

Bit 7	Bit 6	Bit 5	Bit 4	Bit 3	Bit 2	Bit 1	Bit 0
PLL_lock	unused	unused	device_ID (2:0)		version(1:0)		
0	0	0	0	0	0	0	1

- PLL_lock : Asserted when the internal PLL is locked. (Read Only)
- device_ID(2:0) : Returns '000' for DAC5688. (Read Only)
- version(1:0) : A hardwired register that contains the version of the chip. (Read Only)

Register name: CONFIG1 Address: 0x01, Default 0x0B

Bit 7	Bit 6	Bit 5	Bit 4	Bit 3	Bit 2	Bit 1	Bit 0
inset_mode (1:0)		unused	synchr_clkln	twos	inv_inclk	interp_valule(1:0)	
0	0	0	0	1	0	1	1

- inset_mode(1:0)** : Controls the expected format of the input data. For the interleaved modes, TXENABLE or the MSB of the port that does not have data can be used to tell the chip which sample is the A sample. For TXENABLE the sample aligned with the rising edge is A. For the MSB, it is presumed that this signal will toggle with A and B. The MSB should be '1' for A and '0' for B. (** See CONFIG23 **)

inset_mode	Function
00	Normal input on A and B.
01	Interleaved input on A, which is de-interleaved and placed on both A and B data paths. (** See CONFIG23 **)
10	Interleaved input on B, which is de-interleaved and placed on both A and B data paths. (** See CONFIG23 **)
11	Half rate data on A and B inputs. This data is merge together to form a single stream of data on the A data path.

- synchr_clkln** : This turns on the synchronous mode of the dual-clock in mode. In this mode, the CLK2/C and CLK1/C must be synchronous in phase since the slower clock is used to synchronize dividers in the clock distribution circuit.
- twos** : When set (default), the input data format is expected to be 2's complement. When cleared, the input is expected to be offset-binary.
- inv_inclk** : This allows the input clock, the clock driving the input side of the FIFO to be inverted. This allows easier registering of the data (more setup/hold time) in the single-clock mode of the device
- interp_valule(1:0)** : These bits define the interpolation factor:

interp_value	Interpolation Factor
00	1X
01	2X
10	4X
11	8X

Register name: CONFIG2 Address: 0x02, Default 0xE1

Bit 7	Bit 6	Bit 5	Bit 4	Bit 3	Bit 2	Bit 1	Bit 0
diffclk_ena	clk1_in_ena	clk1c_in_ena	clko_SE_hold	fir4_ena	qmc_offset_ena	qmc_corr_ena	mixer_ena
1	1	1	0	0	0	0	1

- diffclk_ena** : When set (default), CLK1 and CLK1C pins are used as a differential clock input. Otherwise, CLK1 pin is used as a single ended input.
- clk1_in_ena** : When set (default), the CLKO_CLK1 pin is configured as the CLK1 input. If cleared, the pin is configured to output an internally generated CLKO as a clock signal for the input data.
- clk1c_in_ena** : When set (default), the LOCK_CLK1C pin is configured as the CLK1C input. If cleared, the pin is configured to output the PLL_LOCK status.
- clko_SE_hold** : When set, the single ended (SE) clock is held to a value of '1' so that the signal doesn't toggle when using the differential clock input.
- fir4_ena** : When set, the FIR4 Inverse SINC filter is enabled. Otherwise it is bypassed
- qmc_offset_ena** : When set, the digital Quadrature Modulator Correction (QMC) offset correction circuitry is enabled.
- qmc_corr_ena** : When set, the QMC phase and gain correction circuitry is enabled.
- mixer_ena** : When set, the Full Mixer (FMIX) is enabled. Otherwise it is bypassed.

Register name: CONFIG3 Address: 0x03, Default 0x00

Bit 7	Bit 6	Bit 5	Bit 4	Bit 3	Bit 2	Bit 1	Bit 0
diffclk_dly(1:0)		clko_dly(1:0)		Reserved(3:0)			
0	0	0	0	0	0	0	0

- diffclk_dly(1:0)** : To allow for a wider range of interfacing, the differential input clock (CLK1/CLK1C) has programmable delay added to its tree.

diffclk_dly	Approximate additional delay
00	0
01	1.0 ns
10	2.0 ns
11	3.0 ns

- clko_dly(1:0)** : Same as above except these bits effect the single ended or internally generated clock

Register name: CONFIG4 Address: 0x04, Default 0x00

Bit 7	Bit 6	Bit 5	Bit 4	Bit 3	Bit 2	Bit 1	Bit 0
ser_dac_data_ena	output_delay(1:0)		B_equals_A	A_equals_B	unused	reva	revb
0	0	0	0	0	0	0	0

- ser_dac_data_ena** : Muxes the ser_dac_data(15:0) to both DACs when asserted.
- output_delay(1:0)** : Delays the output to both DACs from 0 to 3 DAC clock cycles
- B_equals_A** : When set, the DACA data is driving the DACB output.
- A_equals_B** : When set, the DACB data is driving the DACA output.

Bit 4 B_equals_A	Bit 3 A_equals_B	DACB Output	DACA Output	Description
0	0	B data	A data	Normal Output
0	1	B data	B data	Both DACs driven by B data
1	0	A data	A data	Both DACs driven by A data
1	1	A data	B data	Swapped Output

- reva** : Reverse the input bits of the A input port. MSB becomes LSB.
- revb** : Reverse the input bits of the B input port. MSB becomes LSB

Register name: CONFIG5 Address: 0x05, Default 0x22

Bit 7	Bit 6	Bit 5	Bit 4	Bit 3	Bit 2	Bit 1	Bit 0
sif4	sif_sync_sig	clkdiv_sync_ena	clkdiv_sync_sel	Reserved	clkdiv_shift	mixer_gain	unused
0	0	1	0	0	0	1	0

- sif4** : When set, the serial interface (SIF) is a 4 bit interface, otherwise it is a 3 bit interface.
- sif_sync_sig** : SIF created sync signal. Set to '1' to cause a sync and then clear to '0' to remove it.
- clkdiv_sync_ena** : Enables syncing of the clock divider using the sync or TXENABLE pins when the bit is asserted.
- clkdiv_sync_sel** : Selects the input pin to sync the clock dividers. (0 = SYNC, 1 = TXENABLE)
- clkdiv_shift** : When set, a rising edge on the selected sync (see clkdiv_sync_sel) for the clock dividers will cause a slip in the synchronous counter by 1T and is useful for multi-DAC time alignment.
- mixer_gain** : When set, adds 6dB to the mixer gain output.

Register name: CONFIG6 Address: 0x06, Default 0x00 (Synced)

Bit 7	Bit 6	Bit 5	Bit 4	Bit 3	Bit 2	Bit 1	Bit 0
phaseoffset(7:0)							
0	0	0	0	0	0	0	0

phaseoffset(7:0) : See CONFIG7 below.

Register name: CONFIG7 Address: 0x07, Default 0x00 (Synced)

Bit 7	Bit 6	Bit 5	Bit 4	Bit 3	Bit 2	Bit 1	Bit 0
phaseoffset(15:8)							
0	0	0	0	0	0	0	0

phaseoffset(15:8) : This is the phase offset added to the NCO accumulator just before generation of the SIN and COS values. The phase offset is added to the upper 16bits of the NCO accumulator results and these 16 bits are used in the sin/cosine lookup tables.

Register name: CONFIG8 Address: 0x08, Default 0x00 (Synced)

Bit 7	Bit 6	Bit 5	Bit 4	Bit 3	Bit 2	Bit 1	Bit 0
phaseadd(7:0)							
0	0	0	0	0	0	0	0

phaseadd(7:0) : See CONFIG11 below.

Register name: CONFIG9 Address: 0x09, Default 0x00 (Synced)

Bit 7	Bit 6	Bit 5	Bit 4	Bit 3	Bit 2	Bit 1	Bit 0
phaseadd(15:8)							
0	0	0	0	0	0	0	0

phaseadd(15:8) : See CONFIG11 below.

Register name: CONFIG10 Address: 0x0A, Default 0x00 (Synced)

Bit 7	Bit 6	Bit 5	Bit 4	Bit 3	Bit 2	Bit 1	Bit 0
phaseadd(23:16)							
0	0	0	0	0	0	0	0

phaseadd(23:16) : See CONFIG11 below.

Register name: CONFIG11 Address: 0x0B, Default 0x00 (Synced)

Bit 7	Bit 6	Bit 5	Bit 4	Bit 3	Bit 2	Bit 1	Bit 0
phaseadd(31:24)							
0	0	0	0	0	0	0	0

phaseadd(31:24) : The phaseadd(31:24) value is used to determine the frequency of the NCO. The two's complement formatted value can be positive or negative and the LSB is equal to $F_s/(2^{32})$.

Register name: CONFIG12 Address: 0x0C, Default 0x00 (Synced)

Bit 7	Bit 6	Bit 5	Bit 4	Bit 3	Bit 2	Bit 1	Bit 0
qmc_gaina(7:0)							
0	0	0	0	0	0	0	0

qmc_gaina(7:0) : Lower 8 bits of the 11-bit Quadrature Modulator Correction (QMC) gain word for DACA. The upper 3 bits are in the CONFIG15 register. The full 11-bit qmc_gaina(10:0) word is formatted as UNSIGNED with a range of 0 to 1.9990 and the default gain is 1.0000. The implied decimal point for the multiplication is between bit 9 and bit 10. Refer to formatting reference below.

qmc_gaina(10:0) [Binary]	qmc_gaina(10:0) [Decimal]	Format	Gain Value
00000000000	0	$0 + 0/1024 =$	0.0000000
00000000001	1	$0 + 1/1024 =$	0.0009766
.....
01111111111	1023	$0 + 1023/1024 =$	0.9990234
10000000000	[Default] 1024	$1 + 0/1024 =$	1.0000000
10000000001	1025	$1 + 1/1024 =$	1.0009766
.....
11111111111	2047	$1 + 1023/1024 =$	1.9990234

Register name: CONFIG13 Address: 0x0D, Default 0x00 (Synced)

Bit 7	Bit 6	Bit 5	Bit 4	Bit 3	Bit 2	Bit 1	Bit 0
qmc_gainb(7:0)							
0	0	0	0	0	0	0	0

qmc_gainb(7:0) : Lower 8 bits of the 11-bit QMC gain word for DACB. The upper 3 bits are in CONFIG15 register. Refer to CONFIG12 above for formatting.

Register name: CONFIG14 Address: 0x0E, Default 0x00 (Synced)

Bit 7	Bit 6	Bit 5	Bit 4	Bit 3	Bit 2	Bit 1	Bit 0
qmc_phase(7:0)							
0	0	0	0	0	0	0	0

qmc_phase(7:0) : Lower 8 bits of the 10-bit Quadrature Modulator Correction (QMC) phase word. The upper 2 bits are in the CONFIG15 register. The full 11-bit **qmc_phase(9:0)** correction word is formatted as two's complement and scaled to occupy a range of -0.125 to 0.12475 and a default phase correction 0.00. To accomplish QMC phase correction, this value is multiplied by the current 'Q' sample, then summed into the 'I' sample. Refer to formatting reference below.

qmc_phase(9:0) [Binary]	qmc_phase(9:0) [Decimal]	Format	Phase Correction
1000000000	-512	$(-1 + 0/512) / 8 =$	-0.1250000
1000000001	-511	$(-1 + 1/512) / 8 =$	-0.1234559
.....
1111111111	-1	$(-1 + 511/512) / 8 =$	-0.0002441
0000000000	[Default] 0	$(+0 + 0/512) / 8 =$	+0.0000000
0000000001	1	$(+0 + 1/512) / 8 =$	+0.0002441
.....
0111111111	511	$(+0 + 511/512) / 8 =$	+0.1247559

Register name: CONFIG15 Address: 0x0F, Default 0x24 (Synced)

Bit 7	Bit 6	Bit 5	Bit 4	Bit 3	Bit 2	Bit 1	Bit 0
qmc_phase(9:8)		qmc_gaina(10:8)			qmc_gainb(10:8)		
0	0	1	0	0	1	0	0

- qmc_phase(9:8)** : Upper 2 bits of **qmc_phase** term. Defaults to zero.
- qmc_gaina(10:8)** : Upper 3 bits of **qmc_gaina** term. Defaults to unity gain.
- qmc_gainb(10:8)** : Upper 3 bits of the **qmc_gainb** term. Defaults to unity gain.

Register name: CONFIG16 Address: 0x10, Default 0x00 (Synced)

Bit 7	Bit 6	Bit 5	Bit 4	Bit 3	Bit 2	Bit 1	Bit 0
qmc_offseta(7:0)							
0	0	0	0	0	0	0	0

qmc_offseta(7:0) : Lower 8 bits of the DACA offset correction. The upper 5 bits are in CONFIG18 register. The offset is measured in DAC LSBs.

Register name: CONFIG17 Address: 0x11, Default 0x00 (Synced)

Bit 7	Bit 6	Bit 5	Bit 4	Bit 3	Bit 2	Bit 1	Bit 0
qmc_offsetb(7:0)							
0	0	0	0	0	0	0	0

qmc_offsetb(7:0) : Lower 8 bits of the DACB offset correction. The upper 5 bits are in CONFIG19 register. The offset is measured in DAC LSBs.

Register name: CONFIG18 Address: 0x12, Default 0x00 (Synced)

Bit 7	Bit 6	Bit 5	Bit 4	Bit 3	Bit 2	Bit 1	Bit 0
qmc_offseta(12:8)					unused	unused	unused
0	0	0	0	0	0	0	0

qmc_offseta(12:8) : Upper 5 bits of the DACA offset correction.

Register name: CONFIG19 Address: 0x13, Default 0x00 (Synced)

Bit 7	Bit 6	Bit 5	Bit 4	Bit 3	Bit 2	Bit 1	Bit 0
qmc_offsetb(12:8)					unused	unused	unused
0	0	0	0	0	0	0	0

qmc_offsetb(12:8) : Upper 5 bits of the DACB offset correction.

Register name: CONFIG20 Address: 0x14, Default 0x00

Bit 7	Bit 6	Bit 5	Bit 4	Bit 3	Bit 2	Bit 1	Bit 0
ser_dac_data(7:0)							
0	0	0	0	0	0	0	0

ser_dac_data(7:0) : Lower 8 bits of the serial interface controlled DAC value. This data is routed to both DACs when enabled via **ser_dac_data_ena** in CONFIG4. Value is expected in 2s complement format.

Register name: CONFIG21 Address: 0x15, Default 0x00

Bit 7	Bit 6	Bit 5	Bit 4	Bit 3	Bit 2	Bit 1	Bit 0
ser_dac_data(15:8)							
0	0	0	0	0	0	0	0

ser_dac_data(15:8) : Upper 8 bits of the serial interface controlled DAC value. This data is routed to both DACs when enabled via **ser_dac_data_ena** in CONFIG4. Value is expected in 2's complement format.

Register name: CONFIG22 Address: 0x16, Default 0x15

Bit 7	Bit 6	Bit 5	Bit 4	Bit 3	Bit 2	Bit 1	Bit 0
nco_sel(1:0)		nco_reg_sel(1:0)		qmcorr_reg_sel(1:0)		qmoffset_reg_sel(1:0)	
0	0	0	1	0	1	0	1

nco_sel(1:0) : Selects the signal to use as the sync for the NCO accumulator.

nco_reg_sel(1:0) : Selects the signal to use as the sync for loading the NCO registers.

qmcorr_reg_sel(1:0) : Selects the signal to use as the sync for loading the QM correction registers.

qmoffset_reg_sel(1:0) : Selects the signal to use as the sync for loading the QM offset correction registers.

*_sel (1:0)	Sync selected
00	TXENABLE from FIFO output
01	SYNC from FIFO output
10	sync_SIF_sig (via CONFIG5)
11	Always zero

Register name: CONFIG23 Address: 0x17, Default 0x15

Bit 7	Bit 6	Bit 5	Bit 4	Bit 3	Bit 2	Bit 1	Bit 0
unused	unused	fifo_sel(2:0)			aflag_sel	unused	unused
0	0	0	1	0	1	0	1

fifo_sel(2:0) : Selects the sync source for the FIFO from the table below. For the case where the sync is dependent on the first transition of the input data MSB: Once the transition occurs, the only way to get another sync it to reset the device or to program **fifo_sel** to another value

fifo_sel (2:0)	Sync selected
000	TXENABLE from pin
001	SYNC from pin
010	sync_SIF_sig (via CONFIG5)
011	Always zero
100	1 st transition on DA MSB
101	1 st transition on DB MSB
110	Always zero
111	Always one

aflag_sel : When set, the MSB of the input opposite of incoming data is used to determine the A sample. When cleared, rising edge of TXENABLE is used. Refer to [Figure 37](#).

Register name: CONFIG24 Address: 0x18, Default 0x80

Bit 7	Bit 6	Bit 5	Bit 4	Bit 3	Bit 2	Bit 1	Bit 0
fifo_sync_strt(3:0)				Unused	Unused	Unused	Unused
1	0	0	0	0	0	0	0

fifo_sync_strt(3:0) : When the sync to the FIFO occurs, this is the value loaded into the FIFO output position counter. With this value the initial difference between input and output pointers can be controlled. This may be helpful in syncing multiple chips or controlling the delay through the device.

Register name: CONFIG25 Address: 0x19, Default 0x00

Bit 7	Bit 6	Bit 5	Bit 4	Bit 3	Bit 2	Bit 1	Bit 0
Unused	Unused	Unused	Unused	Unused	Unused	Unused	Unused
0	0	0	0	0	0	0	0

Register name: CONFIG26 Address: 0x1A, Default 0x0D

Bit 7	Bit 6	Bit 5	Bit 4	Bit 3	Bit 2	Bit 1	Bit 0
io_1p8_3p3	Unused	sleepb	sleepa	isbiaslpfb_a	isbiaslpfb_b	PLL_sleep	PLL_ena
0	0	0	0	1	1	0	1

io_1p8_3p3 : Used to program the digital input voltage threshold levels. '0'=3.3V tolerate pads and '1'=1.8V tolerate pads. Applies to following digital pins: CLKO_CLK1, LOCK_CLK1C, DA[15:0], DB[15:0], SYNC, RESETB, SCLK, SDENB, SDIO (input only) and TXENABLE.

sleepb : When set, DACB is put into sleep mode. Putting the DAC into single DAC mode does not automatically assert this signal, so for minimum power in single DAC mode, also program this register bit.

sleepa : When set, DACA is put into sleep mode. Note: If DACA channel is in sleep mode (**sleepa** = '1') the DACB channel is also forced in to sleep mode.

isbiaslpfb_a : Turns on the low pass filter for the current source bias in the DACA when cleared. The low pass filter will set a corner at ~472kHz when low and ~95 kHz when high.

isbiaslpfb_b : Turns on the low pass filter for the current source bias in the DACB when cleared. The low pass filter will set a corner at ~472kHz when low and ~95 kHz when high.

PLL_sleep : When set, the PLL is put into sleep mode. Bypassing the PLL does not automatically but it into sleep mode.

PLL_ena : When set, the PLL is on and its output clock is being used as the DAC clock.

Register name: CONFIG27 Address: 0x1B, Default 0xFF

Bit 7	Bit 6	Bit 5	Bit 4	Bit 3	Bit 2	Bit 1	Bit 0
coarse_daca(3:0)				coarse_dacb(3:0)			
1	1	1	1	1	1	1	1

coarse_daca(3:0) : Scales the output current in 16 equal steps.

$$\frac{V_{EXTIO}}{R_{bias}} \times (DACA_{gain} + 1)$$

coarse_dacb(3:0) : Same as above except for DACB.

Register name: CONFIG28 Address: 0x1C, Default 0x00

Bit 7	Bit 6	Bit 5	Bit 4	Bit 3	Bit 2	Bit 1	Bit 0
Reserved	Reserved	Reserved	Reserved	Reserved	Reserved	Reserved	Reserved
0	0	0	0	0	0	0	0

Register name: CONFIG29 Address: 0x1D, Default 0x00

Bit 7	Bit 6	Bit 5	Bit 4	Bit 3	Bit 2	Bit 1	Bit 0
PLL_m(4:0)				PLL_n(2:0)			
0	0	0	0	0	0	0	0

PLL_m : M portion of the M/N divider of the PLL thermometer encoded:

PLL_m(4:0)	M value
00000	1
00001	2
00011	4
00111	8
01111	16
11111	32
All other values	Invalid

PLL_n : N portion of the M/N divider of the PLL thermometer encoded. If supplying a high rate CLK2/C frequency, the PLL_n value should be used to divide down the input CLK2/C to maintain a maximum PFD operating of 160 MHz.

PLL_n(2:0)	n value
000	1
001	2
011	4
111	8
All other values	Invalid

PLL Function:

$$f_{VCO} = \left[\frac{(M)}{(N)} \right] \times f_{ref}$$

where f_{ref} is the frequency of the external DAC clock input on the CLK2/C pins

Register name: CONFIG30 Address: 0x1E, Default 0x00

Bit 7	Bit 6	Bit 5	Bit 4	Bit 3	Bit 2	Bit 1	Bit 0
PLL_LPF_reset	VCO_div2	PLL_gain(1:0)		PLL_range(3:0)			
0	0	0	0	0	0	0	0

- PLL_LPF_reset** : When set, can be used to hold the PLL loop filter at 0 volts.
- VCO_div2** : When set, the PLL CLOCK output is 1/2 the PLL VCO frequency. Used to run the VCO at 2X the desired clock frequency to reduce phase noise for lower DAC clock rates.
- PLL_gain(1:0)** : Used to adjust the PLL's Voltage Controlled Oscillator (VCO) gain, K_{VCO} . Refer to the Electrical Characteristics table. By increasing the **PLL_gain**, the VCO can cover a broader range of frequencies; however, the higher gain also increases the phase noise of the PLL. In general, lower **PLL_gain** settings result in lower phase noise. The K_{VCO} of the VCO can also affect the PLL stability and is used to determine the loop filter components. See section on determining the PLL filter components for more detail.
- PLL_range(3:0)** : Used to adjust the bias current of the VCO. By increasing the bias current, the oscillator can reach higher frequencies. Refer to the Electrical Characteristics table.
 '0000' – minimum bias current and lowest VCO frequency range
 '1111' – maximum bias current and highest VCO frequency range

DETAILED DESCRIPTION

EXAMPLE SYSTEM DIAGRAM

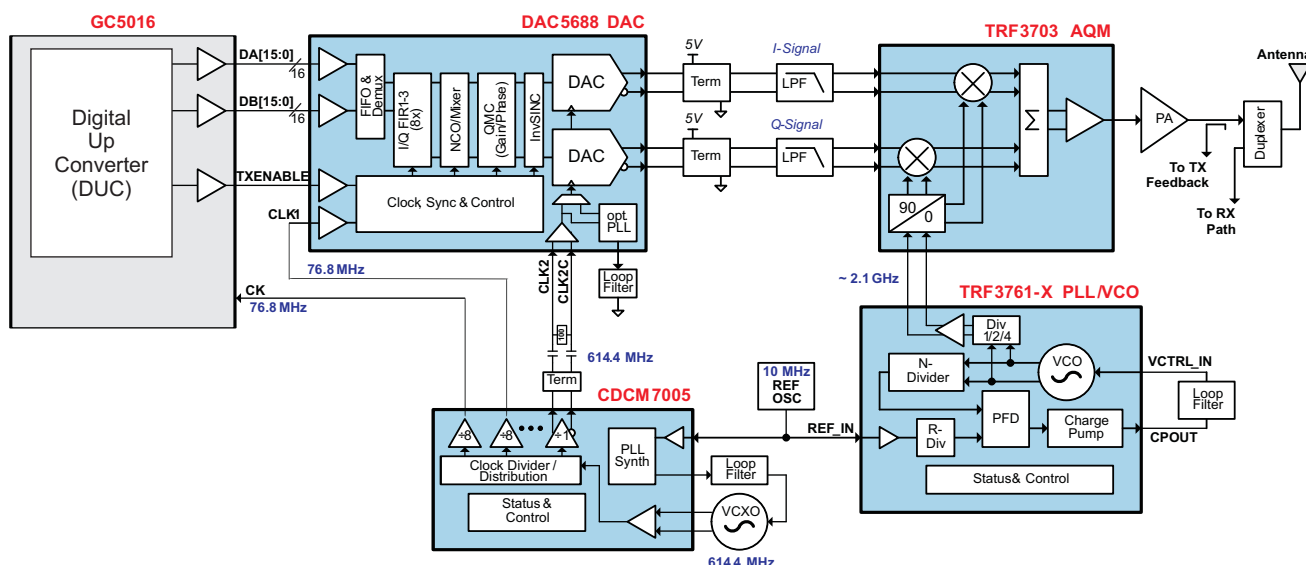

Figure 19. Example System Diagram: Direct Conversion with 8x interpolation

SERIAL INTERFACE

The serial port of the DAC5688 is a flexible serial interface which communicates with industry standard microprocessors and microcontrollers. The interface provides read/write access to all registers used to define the operating modes of DAC5688. It is compatible with most synchronous transfer formats and can be configured as a 3 or 4 pin interface by **SIF4** in register **CONFIG5**. In both configurations, **SCLK** is the serial interface input clock and **SDENB** is serial interface enable. For 3 pin configuration, **SDIO** is a bidirectional pin for both data in and data out. For 4 pin configuration, **SDIO** is data in only and **SDO** is data out only. Data is input into the device with the rising edge of **SCLK**. Data is output from the device on the falling edge of **SCLK**.

Each read/write operation is framed by signal **SDENB** (Serial Data Enable Bar) asserted low for 2 to 5 bytes, depending on the data length to be transferred (1–4 bytes). The first frame byte is the instruction cycle which identifies the following data transfer cycle as read or write, how many bytes to transfer, and what address to transfer the data. [Table 2](#) indicates the function of each bit in the instruction cycle and is followed by a detailed description of each bit. Frame bytes 2 to 5 comprise the data transfer cycle.

Table 2. Instruction Byte of the Serial Interface

Bit	7	6	5	4	3	2	1	0
Description	R/W	N1	N0	A4	A3	A2	A1	A0

R/W Identifies the following data transfer cycle as a read or write operation. A high indicates a read operation from DAC5688 and a low indicates a write operation to DAC5688.

[N1 : N0] Identifies the number of data bytes to be transferred per Table 3. Data is transferred MSB first.

Table 3. Number of Transferred Bytes Within One Communication Frame

N1	N0	Description
0	0	Transfer 1 Byte
0	1	Transfer 2 Bytes
1	0	Transfer 3 Bytes
1	1	Transfer 4 Bytes

[A4 : A0] Identifies the address of the register to be accessed during the read or write operation. For multi-byte transfers, this address is the starting address. Note that the address is written to the DAC5688 MSB first and counts down for each byte

Figure 20 shows the serial interface timing diagram for a DAC5688 write operation. **SCLK** is the serial interface clock input to DAC5688. Serial data enable **SDENB** is an active low input to DAC5688. **SDIO** is serial data in. Input data to DAC5688 is clocked on the rising edges of **SCLK**.

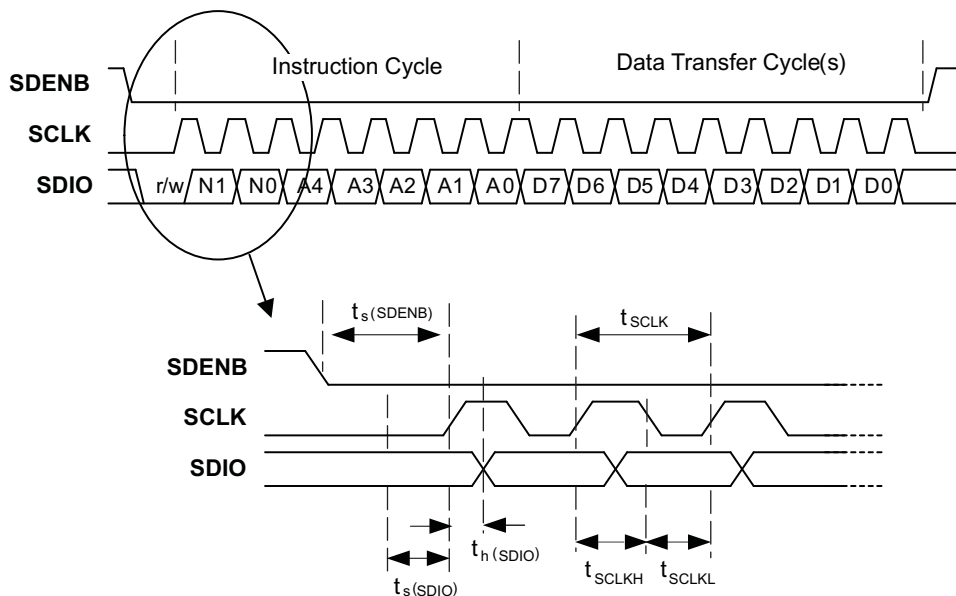

Figure 20. Serial Interface Write Timing Diagram

Figure 21 shows the serial interface timing diagram for a DAC5688 read operation. **SCLK** is the serial interface clock input to DAC5688. Serial data enable **SDENB** is an active low input to DAC5688. **SDIO** is serial data in during the instruction cycle. In 3 pin configuration, **SDIO** is data out from DAC5688 during the data transfer cycle(s), while **SDO** is in a high-impedance state. In 4 pin configuration, **SDO** is data out from DAC5688 during the data transfer cycle(s). The **SDIO/SDO** data is output on the falling edge of **SCLK**. At the end of the data transfer, **SDO** will output low on the final falling edge of **SCLK** until the rising edge of **SDENB** when it will 3-state.

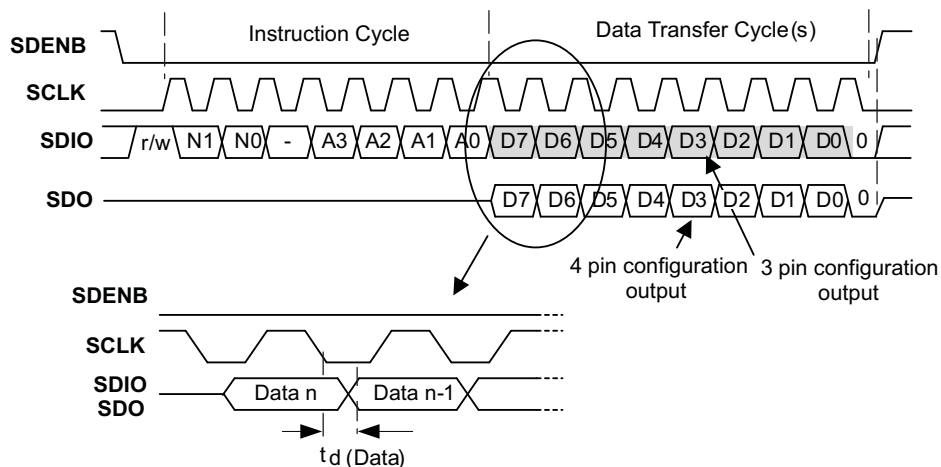

Figure 21. Serial Interface Read Timing Diagram

FIR FILTERS

Figure 22 shows the magnitude spectrum response for FIR1, a 67-tap interpolating half-band filter. The transition band is from 0.4 to $0.6 \times f_{IN}$ (the input data rate for the FIR filter) with <0.002 -dB of pass-band ripple and > 80 -dB stop-band attenuation. Figure 23 shows the transition band region from 0.37 to $0.47 \times f_{IN}$. Up to $0.458 \times f_{IN}$ there is less than 0.5 dB of attenuation.

Figure 24 shows the magnitude spectrum response for the 19-tap FIR2 filter. The transition band is from 0.25 to $0.75 \times f_{IN}$ (the input data rate for the FIR filter). For $4x$ interpolation modes, the composite filter response is shown in Figure 25.

Figure 26 shows the magnitude spectrum response for the 11-tap FIR3 filter. For $8x$ interpolation modes, the composite filter response is shown in Figure 27.

The DAC5688 also has a 9-tap non-interpolating inverse sinc filter (FIR4) running at the DAC update rate (f_{DAC}) that can be used to flatten the frequency response of the sample and hold output. The DAC sample and hold output set the output current and holds it constant for one DAC clock cycle until the next sample, resulting in the well known $\sin(x)/x$ or $\text{sinc}(x)$ frequency response shown in Figure 28 (red dash-dotted line). The inverse sinc filter response (Figure 28, blue dashed line) has the opposite frequency response between 0 to $0.4 \times f_{DAC}$, resulting in the combined response (Figure 28, green solid line). Between 0 to $0.4 \times f_{DAC}$, the inverse sinc filter compensates the sample and hold rolloff with less than 0.03 -dB error.

The inverse sinc filter has a gain > 1 at all frequencies. Therefore, the signal input to FIR4 must be reduced from full scale to prevent saturation in the filter. The amount of backoff required depends on the signal frequency, and is set such that at the signal frequencies the combination of the input signal and filter response is less than 1 (0 dB). For example, if the signal input to FIR4 is at $0.25 \times f_{DAC}$, the response of FIR4 is 0.9 dB, and the signal must be backed off from full scale by 0.9 dB. The gain function in the QMC block can be used to set reduce amplitude of the input signal. The advantage of FIR4 having a positive gain at all frequencies is that the user is then able to optimized backoff of the signal based on the signal frequency.

The filter taps for all digital filters are listed in Table 4. Note that the loss of signal amplitude may result in lower SNR due to decrease in signal amplitude.

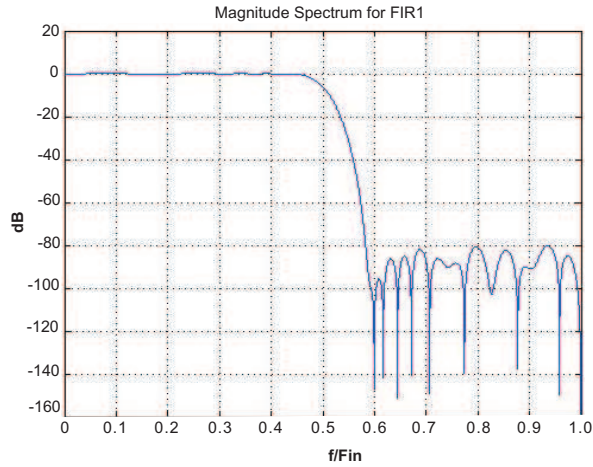

Figure 22. Magnitude Spectrum for FIR1

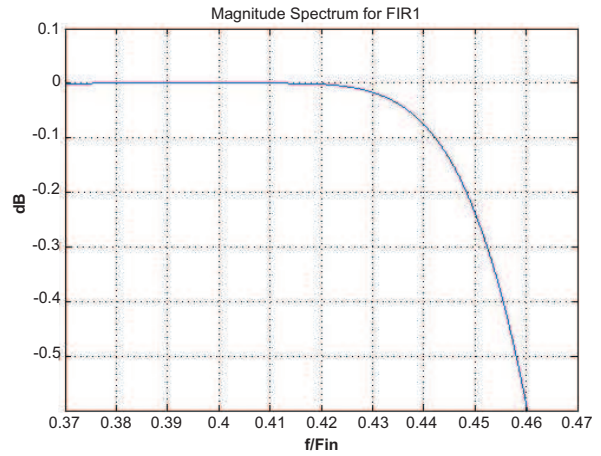

Figure 23. FIR1 Transition Band

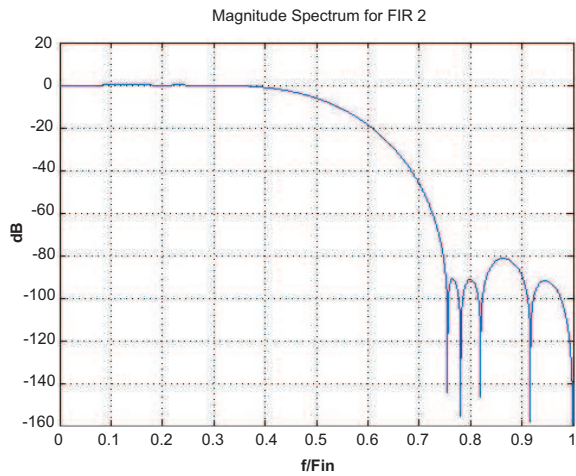

Figure 24. Magnitude Spectrum for FIR2

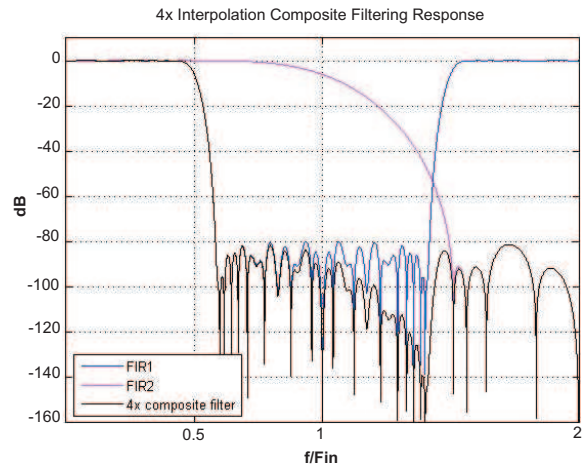

Figure 25. 4x Interpolation Composite Response

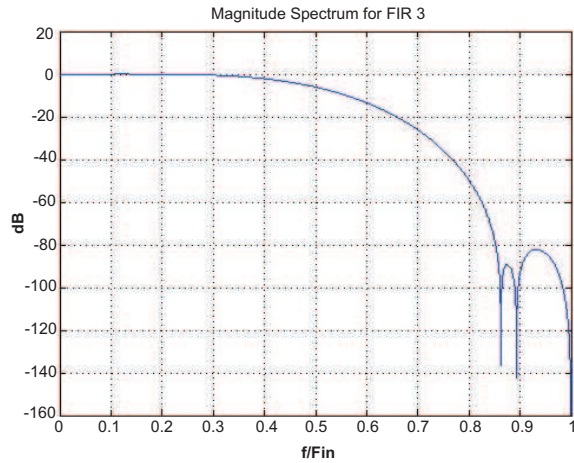

Figure 26. Magnitude Spectrum for FIR3

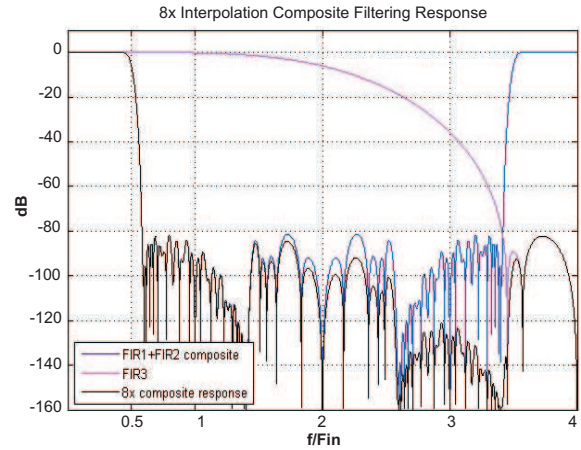

Figure 27. 8x Interpolation Composite Response

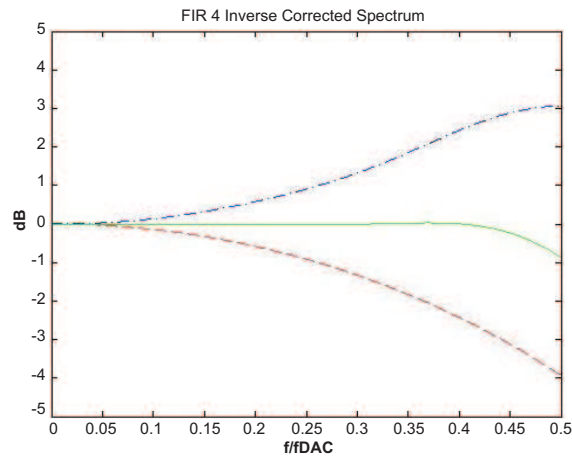

Figure 28. Magnitude Spectrum for FIR4

Table 4. FIR Filter Coefficients

2X Interpolating Half-band Filters						Non-Interpolating Inverse-SINC Filter	
FIR1		FIR2		FIR3		FIR4	
67 Taps		19 Taps		11 Taps		9 Taps	
2	2	9	9	31	31	1	1
0	0	0	0	0	0	-4	-4
-5	-5	-58	-58	-219	-219	13	13
0	0	0	0	0	0	-50	-50
11	11	214	214	1212	1212	592⁽¹⁾	
0	0	0	0	2048⁽¹⁾			
-21	-21	-638	-638				
0	0	0	0				
37	37	2521	2521				
0	0	4096⁽¹⁾					
-61	-61						
0	0						
97	97						
0	0						
-148	-148						
0	0						
218	218						
0	0						
-314	-314						
0	0						
444	444						
0	0						
-624	-624						
0	0						
877	877						
0	0						
-1260	-1260						
0	0						
1916	1916						
0	0						
-3372	-3372						
0	0						
10395	10395						
16384⁽¹⁾							

(1) Center Taps are highlighted in **BOLD**.

Full Complex Mixer (FMIX)

The full complex Mixer (FMIX) block uses a Numerically Controlled Oscillator (NCO) with a 32-bit frequency register **phaseadd(31:0)** and a 16-bit phase register **phaseoffset(15:0)** to provide sin and cos for mixing. The NCO tuning frequency is programmed in CONFIG8 through CONFIG11 registers. Phase offset is programmed in CONFIG6 and CONFIG7 registers. A block-diagram of the NCO is shown below in Figure 29.

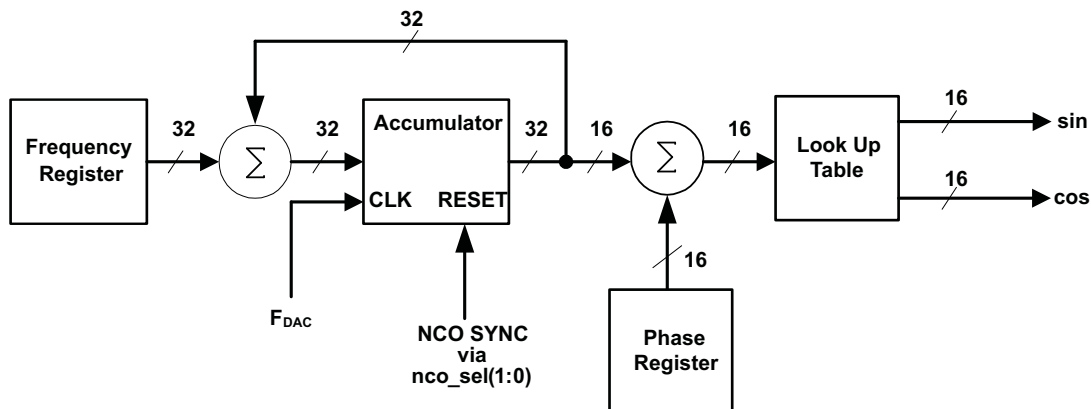

Figure 29. Block-Diagram of the NCO

Synchronization of the NCO occurs by resetting the NCO accumulator to zero. The synchronization source is selected by CONFIG22 **nco_sel(1:0)**. Frequency word f_{ref} in the phaseadd register is added to the accumulator every clock cycle, f_{DAC} . The output frequency of the NCO is

$$f_{NCO} = \frac{f_{ref} \times f_{NCO_CLK}}{2^{32}} \quad (1)$$

Treating channels A and B as a complex vector $I + IxQ$ where $I(t) = A(t)$ and $Q(t) = B(t)$, the output of FMIX $I_{OUT}(t)$ and $Q_{OUT}(t)$ is

$$I_{OUT}(t) = (I_{IN}(t) \cos(2\pi f_{NCO}t + \delta) - Q_{IN}(t) \sin(2\pi f_{NCO}t + \delta)) \times 2^{(mixer_gain - 1)} \quad (2)$$

$$Q_{OUT}(t) = (I_{IN}(t) \sin(2\pi f_{NCO}t + \delta) + Q_{IN}(t) \cos(2\pi f_{NCO}t + \delta)) \times 2^{(mixer_gain - 1)} \quad (3)$$

Where t is the time since the last resetting of the NCO accumulator, δ is the phase offset value and **mixer_gain** is either 0 or 1. δ is given by:

$$\delta = 2\pi \times \text{phase}(15:0) / 2^{16} \quad (4)$$

The maximum output amplitude of FMIX occurs if $I_{IN}(t)$ and $Q_{IN}(t)$ are simultaneously full scale amplitude and the sine and cosine arguments $2\pi f_{NCO}t + \delta$ $(2N-1) \times \pi/4$ ($N = 1, 2, \dots$).

With CONFIG5 **mixer_gain** = 0, the gain through FMIX is $\sqrt{2}/2$ or -3 dB. This loss in signal power is in most cases undesirable, and it is recommended that the gain function of the QMC block be used to increase the signal by 3 dB to compensate. With **mixer_gain** = 1, the gain through FMIX is $\sqrt{2}$ or $+3$ dB, which can cause clipping of the signal if $I_{IN}(t)$ and $Q_{IN}(t)$ are simultaneously near full scale amplitude and should therefore be used with caution.

Quadrature Modulator Correction (QMC)

The Quadrature Modulator Correction (QMC) block provides a means for adjusting the gain and phase of the complex signal. At a quadrature modulator output, gain and phase imbalances result in an undesired sideband signal.

The block diagram for the QMC is shown in Figure 30. The QMC block contains 3 programmable parameters: **qmc_gaina**(10:0), **qmc_gainb**(10:0) and **qmc_phase**(9:0).

Registers **qmc_gaina**(10:0) and **qmc_gainb**(10:0) control the I and Q path gains and are 11 bit values with a range of 0 to approximately 2. This value is used to scale the signal range. Register **qmc_phase**(9:0) controls the phase imbalance between I and Q and is a 10-bit value that ranges from $-1/8$ to approximately $+1/8$. This value is multiplied by each Q sample then summed into the I sample path. This operation is a simplified approximation of a true phase rotation and covers the range from -7.5 to $+7.5$ degrees in 1024 steps.

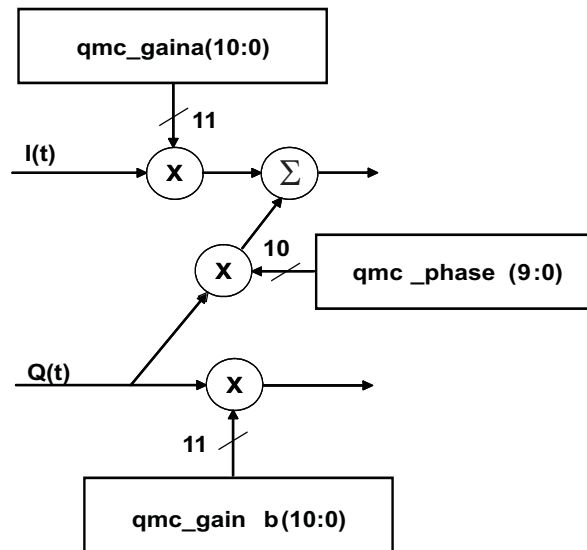

Figure 30. QMC Block Diagram

DAC Offset Control

The **qmc_offseta**(12:0) and **qmc_offsetb**(12:0) values can be used to independently adjust the I and Q path DC offsets. Both offset values are represented in 2s-complement format with a range from -4096 to 4095 .

The offset value adds a digital offset to the digital data before digital-to-analog conversion. Since the offset is added directly to the data it may be necessary to back off the signal to prevent saturation. Both data and offset values are LSB aligned.

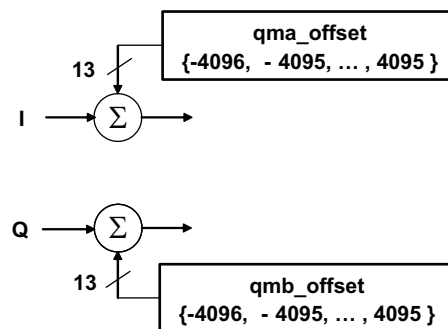

Figure 31. DAC Offset Block

CLOCK MODES

The DAC5688 supports several different clocking modes for generating the internal clocks for the logic and DAC. The clocking modes are selected by programming the register bits below and summarized in [Table 5](#).

Register	Control Bits
CONFIG1	synchr_clkin
CONFIG2	clk1_in_ena, clk1c_in_ena, diffclk_ena
CONFIG26	PLL_ena

Table 5. Summary of Clock Modes and Options

Clocking Mode	Option	CLKO_ CLK1 I/O	Programming Bits				
			synchr_clkin	clk1_in_en	clk1c_in_ena	diffclk_ena	PLL_ena
Dual Synchronous Clock Mode	Diff. CLK1	Input	1	1	1	1	0
	S/E CLK1	Input	1	1	X	0	0
Dual Clock Mode	Diff. CLK1	Input	0	1	1	1	0
	S/E CLK1	Input	0	1	X	0	0
External Clock Mode	CLKO	Output	0	0	X	0	0
PLL Clock Mode	Diff. CLK1	Input	0	1	1	1	1
	S/E CLK1	Input	0	1	X	0	1
	CLKO	Output	0	0	X	0	1

DUAL SYNCHRONOUS CLOCK MODE

In DUAL SYNCHRONOUS CLOCK MODE, the user provides the CLK2/C clock signal at the DAC sample rate and also provides a divided down CLK1 at the input data rate. The CLK1 signal can be differential or single-ended. Refer to Figure 16 for the timing diagram. In this mode the relationship between CLK2 and CLK1 (t_{align}) is critical and used as a synchronizing mechanism for the internal logic. This facilitates multi-DAC synchronization by using dual external clock inputs CLK1 and CLK2 while FIFO data is always written and read from location zero. It is highly recommended that a clock synchronizer device such as the CDCM7005 provide both CLK2/C and CLK1/C inputs. Although CLK1 could be single-ended it is recommended to use a differential clock to ensure proper skews between the two clock inputs.

DUAL CLOCK MODE

In DUAL CLOCK MODE, the user provides the CLK2/C clock signal at the DAC sample rate and also provides a divided down CLK1 at the input data rate. The CLK1 signal can be differential or single-ended. Refer to [Figure 32](#) for the timing diagram. Unlike the DUAL SYNCHRONOUS CLOCK MODE, the t_{align} parameter is not critical because these clocks are not used as a synchronizing mechanism for the internal logic and the FIFO is used as an elastic buffer for the data. Synchronizing in this mode is provided by separate control inputs.

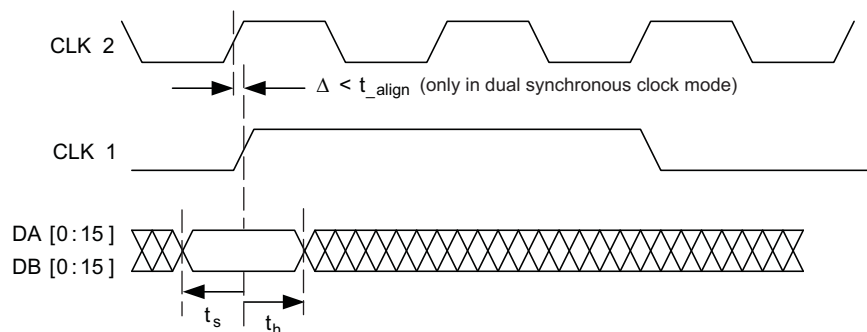

Figure 32. DUAL (SYNCHRONOUS) CLOCK MODE Timing Diagram

EXTERNAL CLOCK MODE

In EXTERNAL CLOCK MODE, the user provides a clock signal at the DAC output sample rate through CLK2/C. The CLK0_CLK1 pin is configured as an output in this mode and will toggle at a required frequency for the configured interpolation rate and data mode. The CLK0_CLK1 clock can be used to drive the input data source (such as digital upconverter) that sends the data to the DAC. Note that the CLK0_CLK1 delay relative to the input CLK2 rising edge ($t_{d(CLK0)}$ in Figure 33) will increase with increasing loads.

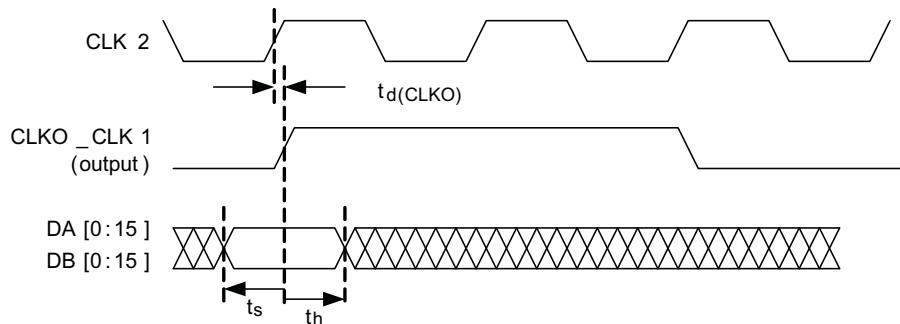

Figure 33. EXTERNAL CLOCK MODE Timing Diagram

PLL CLOCK MODE

In PLL CLOCK MODE, the user provides an external reference clock to the CLK2/C input pins. Refer to Figure 34. An internal clock multiplying PLL uses the lower-rate reference clock to generate a high-rate clock for the DAC. This function is very useful when a high-rate clock is not already available at the system level; however, the internal VCO phase noise in PLL Clock Mode may degrade the quality of the DAC output signal when compared to an external low jitter clock source.

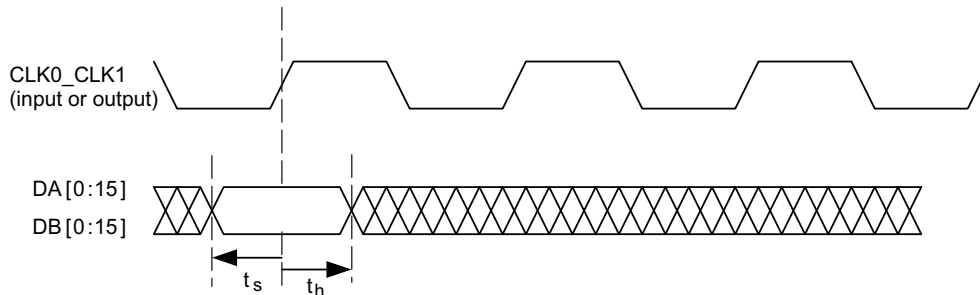

Figure 34. PLL CLOCK MODE Timing Diagram

The internal PLL has a type four phase-frequency detector (PFD) comparing the CLK2/C reference clock with a feedback clock to drive a charge pump controlling the VCO operating voltage and maintaining synchronization between the two clocks. An external low-pass filter is required to control the loop response of the PLL. See the *Low-Pass Filter* section for the filter setting calculations. This is the only mode where the LPF filter applies.

The input reference clock N-Divider is selected by CONFIG29 **PLL_n(2:0)** for values of ÷1, ÷2, ÷4 or ÷8. The VCO feedback clock M-Divider is selected by CONFIG29 **PLL_m(4:0)** for values of ÷1, ÷2, ÷4, ÷8, ÷16 or ÷32. The combination of M-Divider and N-Divider form the clock multiplying ratio of M/N. If the reference clock frequency is greater than 160MHz, use a N-Divider of ÷2, ÷4 or ÷8 to avoid exceeding the maximum PFD operating frequency.

For DAC sample rates less than the maximum VCO operating frequency of 910/2 or **455 MHz**. The phase noise of PLL may improved by using the output divider via CONFIG30 **VCO_div2**. If not using the PLL, clear CONFIG26 **PLL_ena** and set CONFIG26 **PLL_sleep** to reduce power consumption. In some cases, it may be useful to reset the VCO control voltage by toggling CONFIG30 **PLL_LPF_reset**.

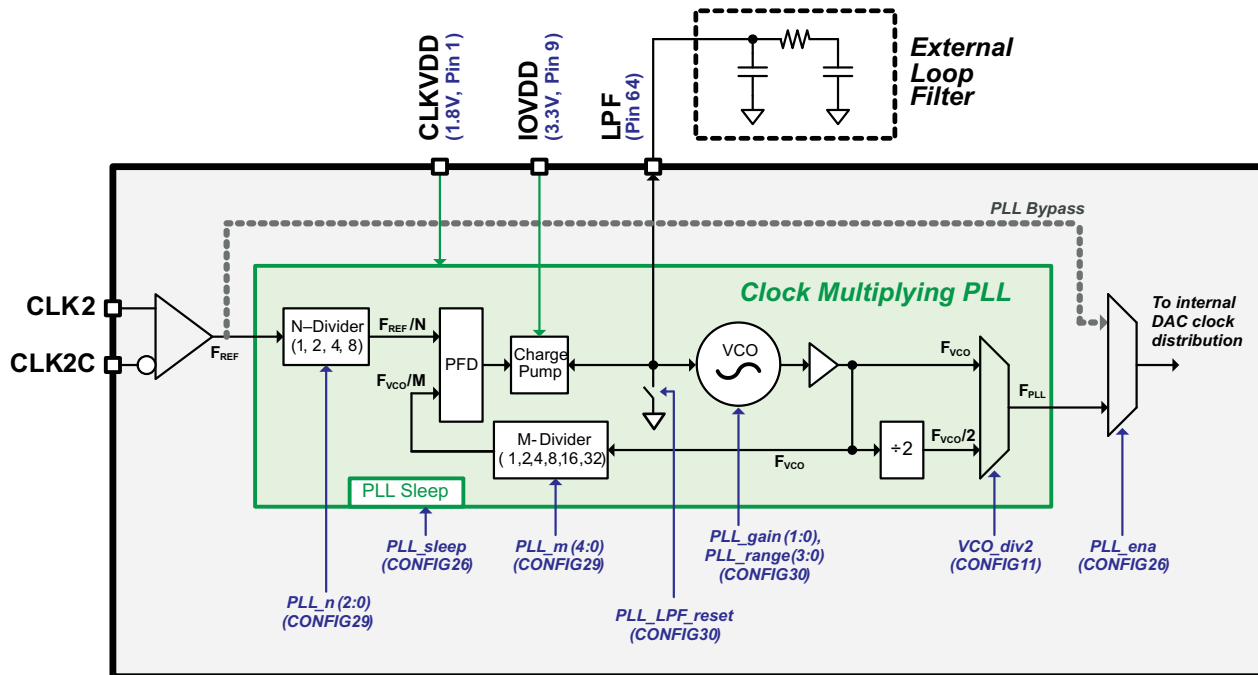

Figure 35. Functional Block Diagram for PLL

DATA BUS MODES

The DAC5688 supports three DATA BUS MODES:

1. DUAL BUS MODE
2. INTERLEAVED BUS MODE
3. HALF RATE BUS MODE

DUAL BUS MODE

In DUAL BUS MODE, the user inputs data on both DA[15:0] and DB[15:0] ports. This mode is selected by setting CONFIG1 `insel_mode(1:0)` = '00'. Refer to Figure 36.

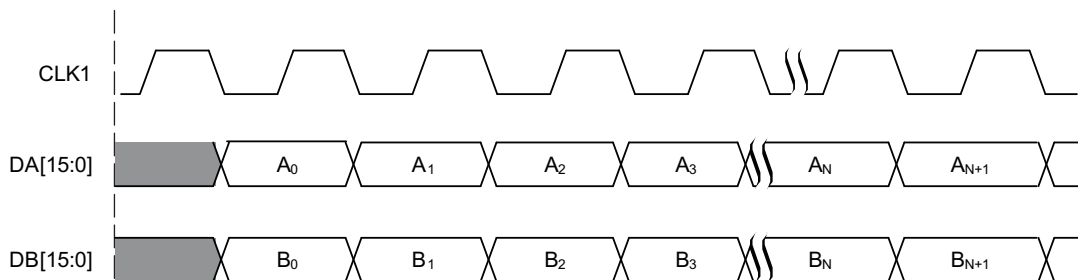

Figure 36. DUAL BUS MODE (Dual Clock Mode)

INTERLEAVED BUS MODE

In INTERLEAVED BUS MODE, the user inputs dual-channel data as an interleaved single data stream to either DA[15:] or DB[15:0] ports. The DAC5688 de-interleaves the input data stream and routes to both A and B data paths. For input data on DA[15:0], set CONFIG1 **inssel_mode[15:0]** = '01'. For input data on DB[15:0], set CONFIG1 **inssel_mode[15:0]** = '10'. In this bus mode, a separate input flag is required to distinguish an A sample from a B sample in the interleaved data stream. This flag can either be the single event rising edge of TXENABLE or the continuous toggling MSB of the port inactive data port. For the TXENABLE flag option, set the CONFIG23 **aflag_sel** bit and the A sample will be expected to be aligned with the rising edge of TXENABLE. For the toggling MSB option, clear the CONFIG23 **aflag_sel** bit and the A sample will be expected for each '1' of the MSB with the B sample is flagged for each '0' of the MSB. Refer to [Figure 37](#).

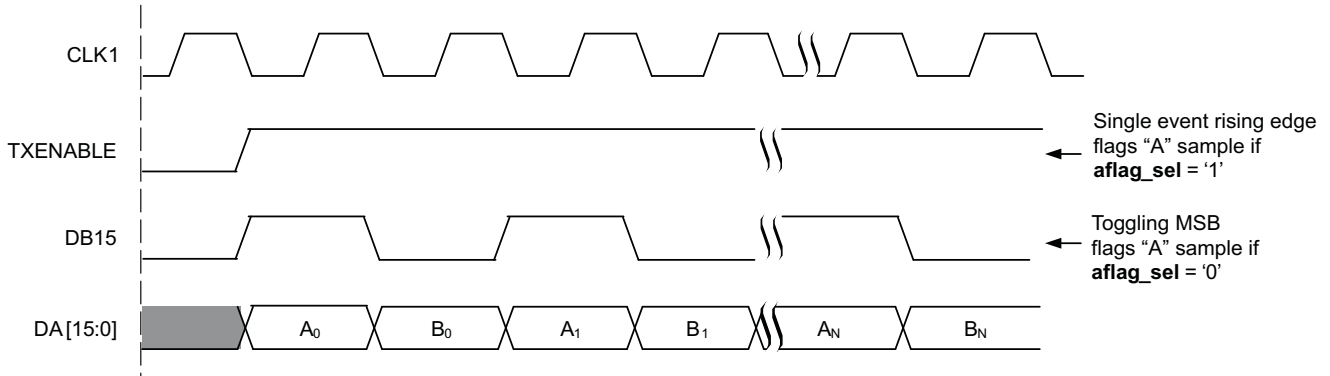

Figure 37. INTERLEAVED BUS MODE on DA[15:0] port (Dual Clock Mode)

HALF RATE BUS MODE

In HALF RATE BUS MODE, the user inputs data on both DA[15:0] and DB[15:0] ports at half rate and input logic merges both data streams into one DAC channel (A). This mode is selected by setting CONFIG1 **inssel_mode[15:0]** = '11'. Refer to [Figure 38](#).

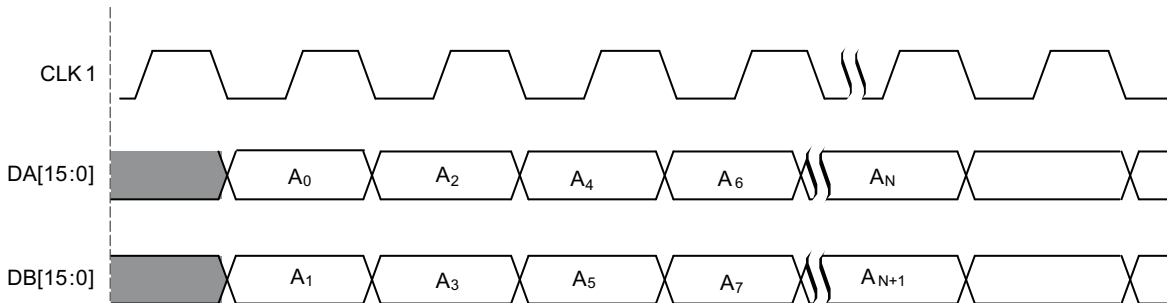

Figure 38. HALF RATE BUS MODE (Dual Clock Mode)

CLK2 and CLK2C Inputs

Figure 39 shows an equivalent circuit for the DAC input clock (CLK2/C).

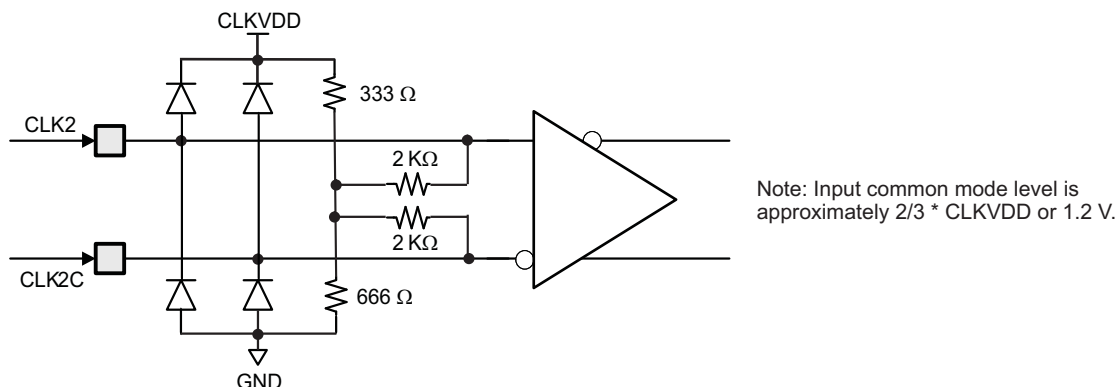

Figure 39. CLK2/C Equivalent Input Circuit

Figure 40 shows the preferred configuration for driving the CLK2/CLK2C input clock with a differential ECL/PECL source.

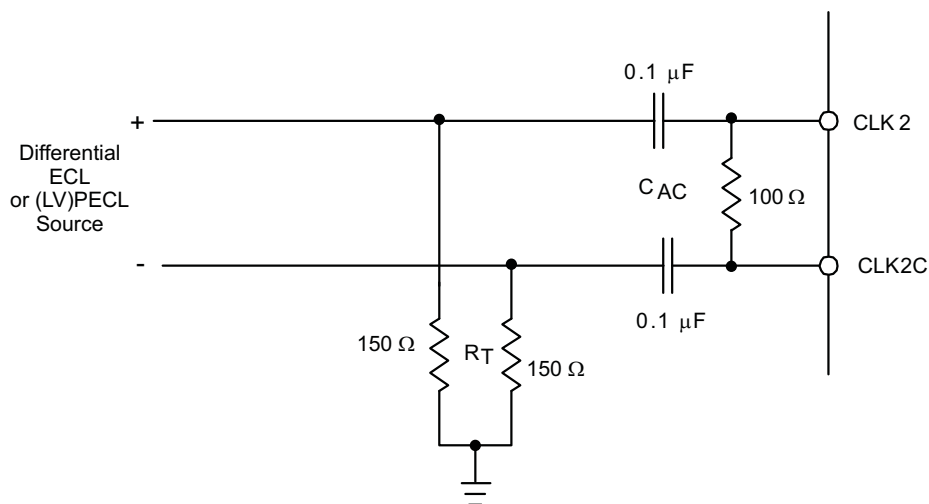

Figure 40. Preferred Clock Input Configuration With a Differential ECL/PECL Clock Source

CLKO_CLK1 and LOCK_CLK1C Pins

Figure 41 shows the functionality of the CLKO_CLK1 and LOCK_CLK1C pins. Refer to Table 5. The controls for these pins are found in the CONFIG2 register and are used in selection of device clocking mode. In single-ended mode (CONFIG2 `diffclk_ena` = '0') refer to Figure 43, both CLKO_CLK1 and LOCK_CLK1C pins have an internal pull-down resistor approximately equivalent to 100kΩ.

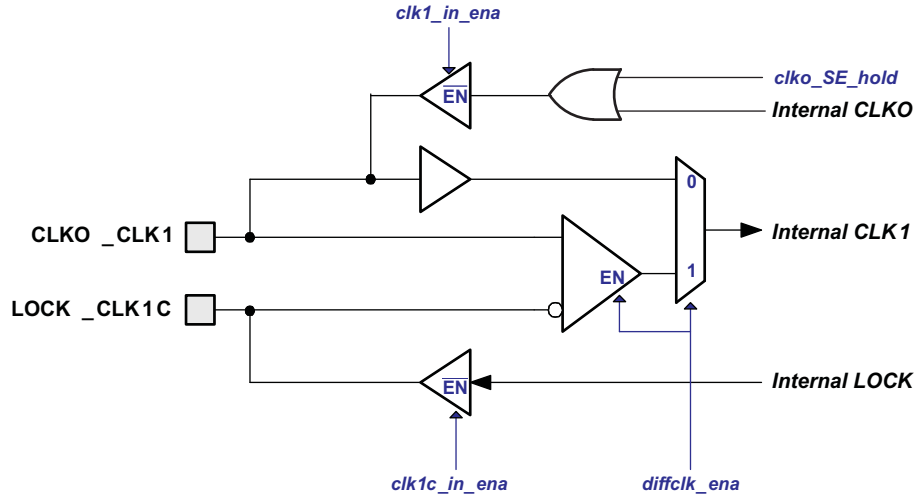

Figure 41. CLKO_CLK1 and LOCK_CLK1C pins bi-directional control

In differential mode (CONFIG2 `diffclk_ena` = '1') the CLKO_CLK1 and LOCK_CLK1C input pins are configured as a differential CLK1/C clock input. Refer Figure 39 for the equivalent circuit.

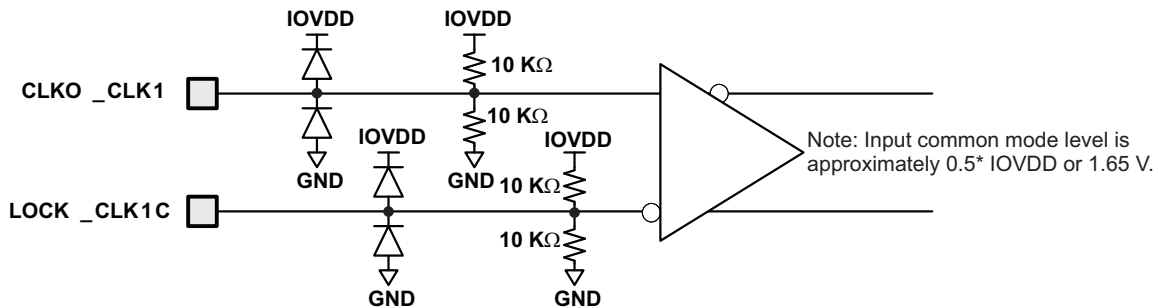

Figure 42. CLKO_CLK1 and LOCK_CLK1C Differential Input Mode Equivalent Circuit

CMOS DIGITAL INPUTS

Figure 43 shows a schematic of the equivalent CMOS digital inputs of the DAC5688. SDIO, SCLK, SYNC, TXENABLE, DA[15:0] and DB[15:0] have pull-down resistors while RESETB and SDENB have pull-up resistors internal the DAC5688. See specification table for logic thresholds. The pull-up and pull-down circuitry is approximately equivalent to 100kΩ.

The input switches levels for all CMOS digital inputs can be changed from 3.3V input levels to 1.8V input levels by programming the CONFIG26 **io_1p8_3p3** register bit. If **io_1p8_3p3** is cleared, the input thresholds are set for 3.3V CMOS levels. If **io_1p8_3p3** is set, the input thresholds are set for 1.8V levels.

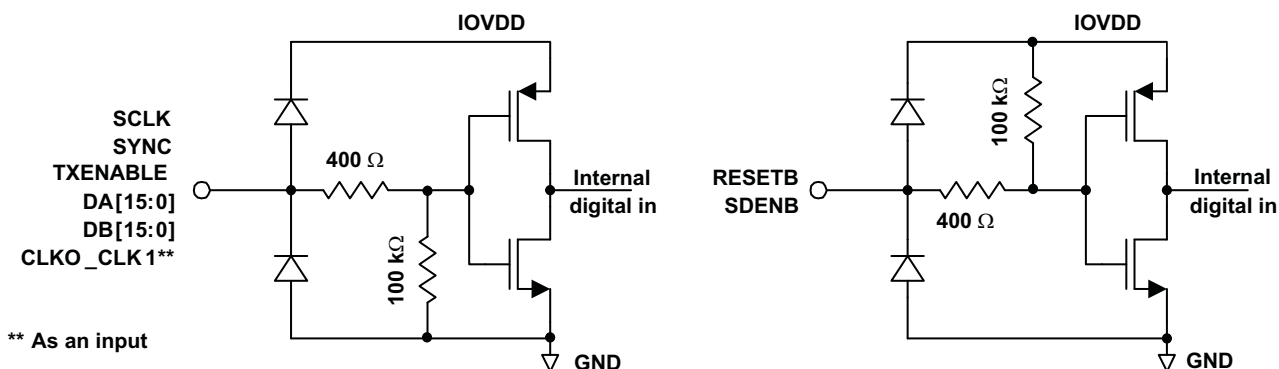

Figure 43. CMOS/TTL Digital Equivalent Input

REFERENCE OPERATION

The DAC5688 uses a bandgap reference and control amplifier for biasing the full-scale output current. The full-scale output current is set by applying an external resistor R_{BIAS} to pin BIASJ. The bias current I_{BIAS} through resistor R_{BIAS} is defined by the on-chip bandgap reference voltage and control amplifier. The default full-scale output current equals 16 times this bias current and can thus be expressed as:

$$I_{OUT_{FS}} = 16 \times I_{BIAS} = 16 \times V_{EXTIO} / R_{BIAS}$$

Each DAC has a 4-bit independent coarse gain control via **coarse_daca(3:0)** and **coarse_dacb (3:0)** in the CONFIG27 register. Using gain control, the $I_{OUT_{FS}}$ can be expressed as:

$$I_{OUTA_{FS}} = (DACA_gain + 1) \times I_{BIAS} = (DACA_gain + 1) \times V_{EXTIO} / R_{BIAS}$$

$$I_{OUTB_{FS}} = (DACB_gain + 1) \times I_{BIAS} = (DACB_gain + 1) \times V_{EXTIO} / R_{BIAS}$$

where V_{EXTIO} is the voltage at terminal EXTIO. The bandgap reference voltage delivers an accurate voltage of 1.2 V. This reference is active when terminal EXTLO is connected to AGND. An external decoupling capacitor C_{EXT} of 0.1 μ F should be connected externally to terminal EXTIO for compensation. The bandgap reference can additionally be used for external reference operation. In that case, an external buffer with high impedance input should be applied in order to limit the bandgap load current to a maximum of 100 nA. The internal reference can be disabled and overridden by an external reference by connecting EXTLO to AVDD. Capacitor C_{EXT} may hence be omitted. Terminal EXTIO thus serves as either input or output node.

The full-scale output current can be adjusted from 20 mA down to 2 mA by varying resistor R_{BIAS} or changing the externally applied reference voltage. The internal control amplifier has a wide input range, supporting the full-scale output current range of 20 dB.

DAC TRANSFER FUNCTION

The CMOS DAC's consist of a segmented array of NMOS current sinks, capable of sinking a full-scale output current up to 20 mA. Differential current switches direct the current to either one of the complementary output nodes IOUT1 or IOUT2. (DACA = IOUTA1 or IOUTA2 and DACB = IOUTB1 or IOUTB2.) Complementary output currents enable differential operation, thus canceling out common mode noise sources (digital feed-through, on-chip and PCB noise), dc offsets, even order distortion components, and increasing signal output power by a factor of two.

The full-scale output current is set using external resistor R_{BIAS} in combination with an on-chip bandgap voltage reference source (+1.2 V) and control amplifier. Current I_{BIAS} through resistor R_{BIAS} is mirrored internally to provide a maximum full-scale output current equal to 16 times I_{BIAS} .

The relation between I_{OUT1} and I_{OUT2} can be expressed as:

$$I_{OUT1} = -I_{OUT_{FS}} - I_{OUT2}$$

We will denote current flowing into a node as – current and current flowing out of a node as + current. Since the output stage is a current sink the current can only flow from $AVDD$ into the I_{OUT1} and I_{OUT2} pins. The output current flow in each pin driving a resistive load can be expressed as:

$$I_{OUT1} = I_{OUT_{FS}} \times (65536 - \text{CODE}) / 65536$$

$$I_{OUT2} = I_{OUT_{FS}} \times \text{CODE} / 65536$$

where CODE is the decimal representation of the DAC data input word.

For the case where I_{OUT1} and I_{OUT2} drive resistor loads R_L directly, this translates into single ended voltages at I_{OUT1} and I_{OUT2} :

$$V_{OUT1} = AVDD - |I_{OUT1}| \times R_L$$

$$V_{OUT2} = AVDD - |I_{OUT2}| \times R_L$$

Assuming that the data is full scale (65536 in offset binary notation) and the R_L is 25 Ω , the differential voltage between pins I_{OUT1} and I_{OUT2} can be expressed as:

$$V_{OUT1} = AVDD - |-0\text{mA}| \times 25 \Omega = 3.3 \text{ V}$$

$$V_{OUT2} = AVDD - |-20\text{mA}| \times 25 \Omega = 2.8 \text{ V}$$

$$V_{DIFF} = V_{OUT1} - V_{OUT2} = 0.5\text{V}$$

Note that care should be taken not to exceed the compliance voltages at node I_{OUT1} and I_{OUT2} , which would lead to increased signal distortion.

DAC OUTPUT SINC RESPONSE

Due to sampled nature of a high-speed DAC's, the well known $\sin(x)/x$ (or SINC) response can significantly attenuate higher frequency output signals. Refer to [Figure 44](#) which shows the unitized SINC attenuation roll-off with respect to the final DAC sample rate in 4 Nyquist zones. For example, if the final DAC sample rate $F_S = 1.0$ GSPS, then a tone at 440MHz will be attenuated by 3.0dB. Although the SINC response can create challenges in frequency planning, one side benefit is the natural attenuation of Nyquist images. The increased over-sampling ratio of the input data provided by the DAC5688's 2x, 4x and 8x digital interpolation modes improve the SINC roll-off (droop) within the original signal's band of interest.

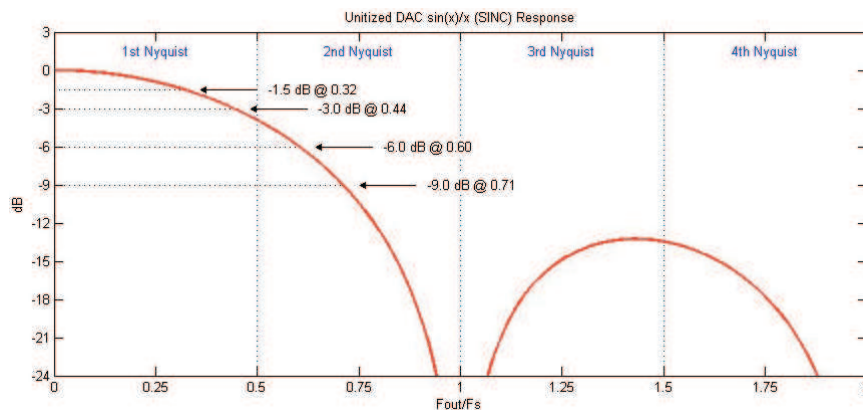

Figure 44. Unitized DAC $\sin(x)/x$ (SINC) Response

ANALOG CURRENT OUTPUTS

Figure 45 shows a simplified schematic of the current source array output with corresponding switches. Differential switches direct the current of each individual NMOS current source to either the positive output node IOUT1 or its complementary negative output node IOUT2. The output impedance is determined by the stack of the current sources and differential switches, and is typically >300 kΩ in parallel with an output capacitance of 5 pF.

The external output resistors are referred to an external ground. The minimum output compliance at nodes IOUT1 and IOUT2 is limited to $AVDD - 0.5\text{ V}$, determined by the CMOS process. Beyond this value, transistor breakdown may occur resulting in reduced reliability of the DAC5688 device. The maximum output compliance voltage at nodes IOUT1 and IOUT2 equals $AVDD + 0.5\text{ V}$. Exceeding the minimum output compliance voltage adversely affects distortion performance and integral non-linearity. The optimum distortion performance for a single-ended or differential output is achieved when the maximum full-scale signal at IOUT1 and IOUT2 does not exceed 0.5 V.

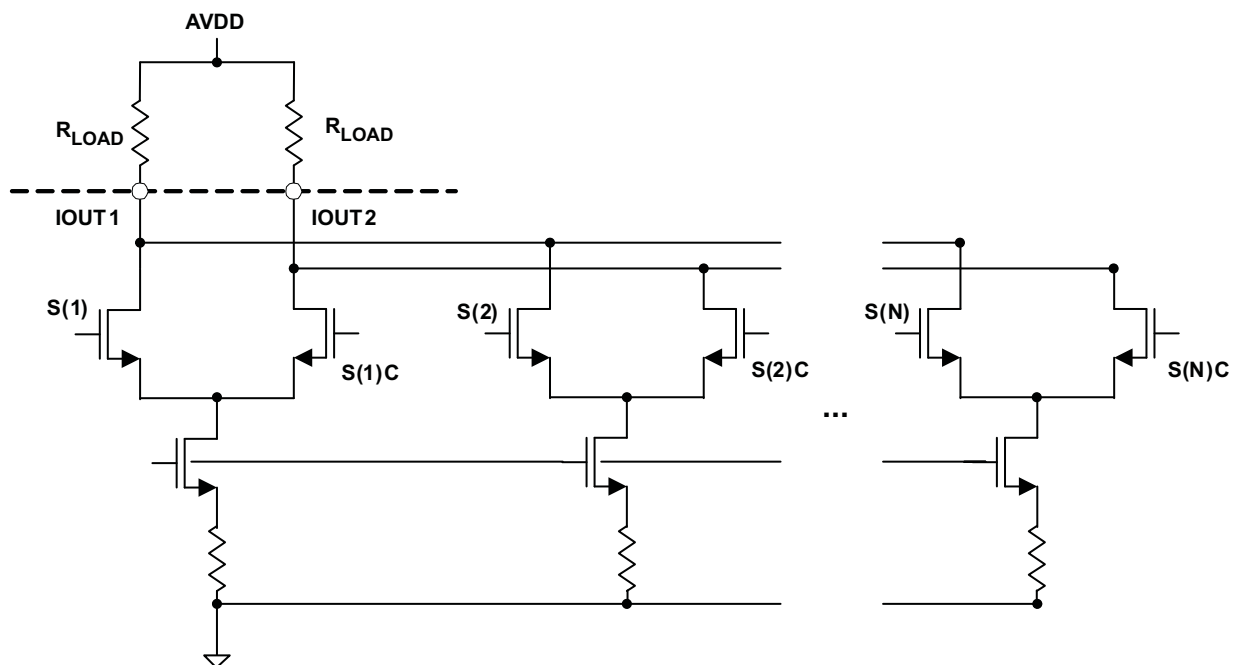

Figure 45. Equivalent Analog Current Output

The DAC5688 can be easily configured to drive a doubly terminated 50Ω cable using a properly selected RF transformer. Figure 46 and Figure 47 show the 50Ω doubly terminated transformer configuration with 1:1 and 4:1 impedance ratio, respectively. Note that the center tap of the primary input of the transformer has to be connected to AVDD to enable a dc current flow. Applying a 20mA full-scale output current would lead to a 0.5 V_{PP} for a 1:1 transformer and a 1 V_{PP} output for a 4:1 transformer. The low dc-impedance between IOUT1 or IOUT2 and the transformer center tap sets the center of the ac-signal at AVDD, so the 1 V_{PP} output for the 4:1 transformer results in an output between $AVDD + 0.5\text{ V}$ and $AVDD - 0.5\text{ V}$.

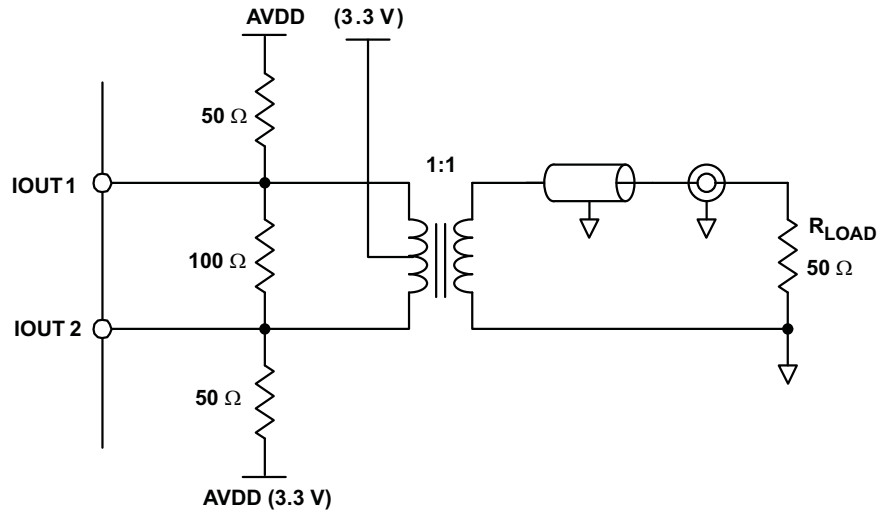

Figure 46. Driving a Doubly Terminated 50Ω Cable Using a 1:1 Impedance Ratio Transformer

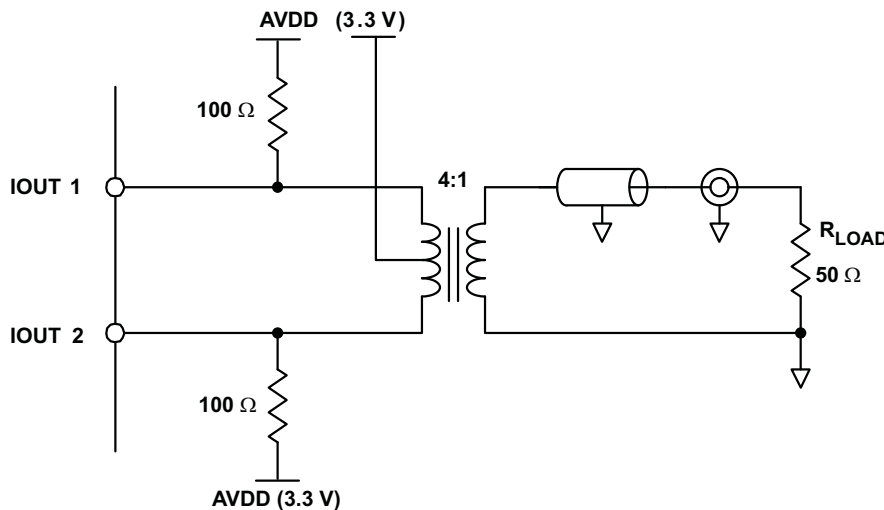

Figure 47. Driving a Doubly Terminated 50Ω Cable Using a 4:1 Impedance Ratio Transformer

PASSIVE INTERFACE TO ANALOG QUADRATURE MODULATORS

A common application in communication systems is to interface the DAC to an IQ modulator like the TRF3703 family of modulators from Texas Instruments. The input of the modulator is generally of high impedance and requires a specific common-mode voltage. A simple resistive network can be used to maintain 50Ω load impedance for the DAC5688 and also provide the necessary common-mode voltages for both the DAC and the modulator.

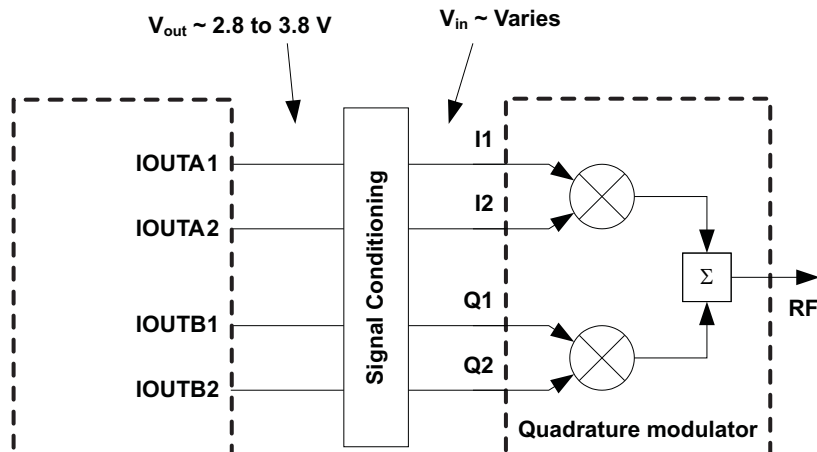

Figure 48. DAC to Analog Quadrature Modulator Interface

The DAC5688 has a maximum 20mA full-scale output and a voltage compliance range of $AVDD \pm 0.5$ V. The TRF3703 IQ modulator family can be operated at three common-mode voltages: 1.5V, 1.7V, and 3.3V.

Figure 49 shows the recommended passive network to interface the DAC5688 to the TRF3703-17 which has a common mode voltage of 1.7V. The network generates the 3.3V common mode required by the DAC output and 1.7V at the modulator input, while still maintaining 50Ω load for the DAC.

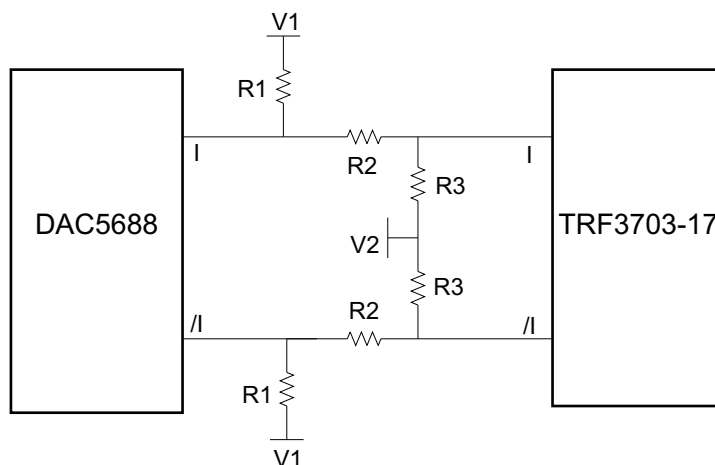

Figure 49. DAC5688 to TRF3703-17 Interface

If $V1$ is set to 5V and $V2$ is set to -5V, the corresponding resistor values are $R1 = 57\Omega$, $R2 = 80\Omega$, and $R3 = 336\Omega$. The loss developed through $R2$ is about -1.86 dB. In the case where there is no -5V supply available and $V2$ is set to 0V, the resistor values are $R1 = 66\Omega$, $R2 = 101\Omega$, and $R3 = 107\Omega$. The loss with these values is -5.76dB.

Figure 50 shows the recommended network for interfacing with the TRF3703-33 which requires a common mode of 3.3V. This is the simplest interface as there is no voltage shift. Because there is no voltage shift there is any loss in the network. With $V1 = 5V$ and $V2 = 0V$, the resistor values are $R1 = 66\Omega$ and $R3 = 208\Omega$.

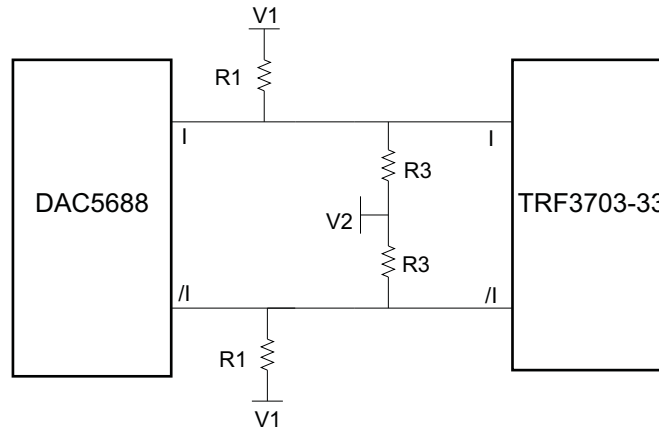

Figure 50. DAC5688 to TRF3703-33 Interface

In most applications a baseband filter is required between the DAC and the modulator to eliminate the DAC images. This filter can be placed after the common-mode biasing network. For the DAC to modulator network shown in Figure 51, R2 and the filter load R4 need to be considered into the DAC impedance. The filter has to be designed for the source impedance created by the resistor combination of $R3 \parallel (R2+R1)$. The effective impedance seen by the DAC is affected by the filter termination resistor resulting in $R1 \parallel (R2+R3 \parallel (R4/2))$.

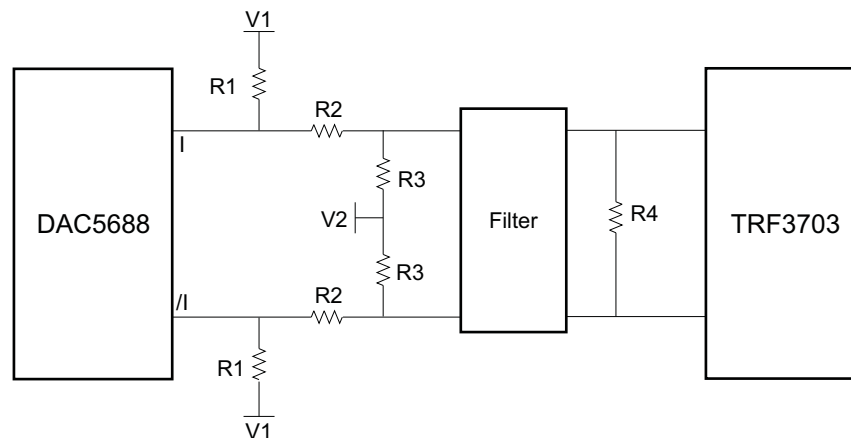

Figure 51. DAC5688 to Modulator Interface with Filter

Factoring in R4 into the DAC load, a typical interface to the TRF3703-17 with V1 = 5V and V2 = 0V results in the following values: R1 = 72Ω, R2 = 116Ω, R3 = 124Ω and R4 = 150Ω. This implies that the filter needs to be designed for 75Ω input and output impedance (single-ended impedance). The common mode levels for the DAC and modulator are maintained at 3.3V and 1.7V and the DAC load is 50Ω. The added load of the filter termination causes the signal to be attenuated by -10.8 dB.

A filter can be implemented in a similar manner to interface with the TRF3703-33. In this case it is much simpler to balance the loads and common mode voltages due to the absence of R2. An added benefit is that there is no loss in this network. With V1 = 5V and V2 = 0V the network can be designed such that R1 = 115Ω, R3 = 681Ω, and R4 = 200Ω. This results in a filter impedance of $R1 \parallel R2=100\Omega$, and a DAC load of $R1 \parallel R3 \parallel (R4/2)$ which is equal to 50Ω. R4 is a differential resistor and does not affect the common mode level created by R1 and R3. The common-mode voltage is set at 3.3 V for a full-scale current of 20mA.

For more information on how to interface the DAC5688 to an analog quadrature modulator please refer to the application reports *Passive Terminations for Current Output DACs* (SLAA399) and *Design of Differential Filters for High-Speed Signal Chains* (SLWA053).

RECOMMENDED STARTUP SEQUENCE

The following startup sequence is recommend to initialization the DAC5688:

1. Supply all 1.8V (CLKVDD, DVDD, VFUSE) and 3.3V (AVDD and IOVDD) voltages.
2. Toggle RESETB pin for a minimum 25 nSec active low pulse width.
3. Provide a stable CLK2/C input clock.
4. Program all desired SIF registers.
5. Provide a sync signal to all digital blocks. The sync input source may be either TXENABLE pin, SYNC pin or a software sync via CONFIG5 **sif_sync_sig** bit; however, only the TXENABLE or SYNC pins are recommended for multi-DAC synchronization. Refer to CONFIG5, CONFIG22 and CONFIG23 registers for sync source selection. Note: Registers CONFIG6 through CONFIG13 all require a sync input to transfer the contents of the control register inputs to the active digital blocks.
6. Provide data flow.

MULTI-DAC SYNCHRONIZATION

If the system has two or more DACs requiring synchronization, the sync signal in Step 5 of the RECOMMENDED STARTUP SEQUENCE must be provided to all the DACs simultaneously. The sync input source must be either the TXENABLE pin or the SYNC pin (the software sync is not recommended).

In some applications such as beamforming it is required that the multiple DACs in the system have constant latency thus resulting in phase aligned outputs. As a result of the clock domain transfer on the DAC5688 FIFO, the outputs of all DACs can only be synchronized to within ± 1 DAC clock cycle in the External and Dual Clock modes. In order to guarantee exact phase alignment between all devices it is required to set up the device in Dual Synchronous Clock mode.

DESIGNING THE PLL LOOP FILTER

To minimize phase noise given for a given f_{DAC} and M/N, the values of **PLL_gain** and **PLL_range** are selected so that G_{VCO} is minimized and within the MIN and MAX frequency for a given setting.

The external loop filter components C1, C2, and R1 are set by the G_{VCO} , M/N, the loop phase margin ϕ_d and the loop bandwidth ω_d . Except for applications where abrupt clock frequency changes require a fast PLL lock time, it is suggested that ϕ_d be set to at least 80 degrees for stable locking and suppression of the phase noise side lobes. Phase margins of 60 degrees or less can be sensitive to board layout and decoupling details.

See [Figure 52](#) for the recommend external loop filter topology. C1, C2, and R1 are calculated by the following equations

$$C1 = \tau1 \left(1 - \frac{\tau2}{\tau3} \right) \quad C2 = \frac{\tau1 - \tau2}{\tau3} \quad R1 = \frac{\tau3^2}{\tau1(\tau3 - \tau2)} \quad (5)$$

where

$$\tau1 = \frac{K_d K_{VCO}}{\omega_d^2} (\tan \phi_d + \sec \phi_d) \quad \tau2 = \frac{1}{\omega_d (\tan \phi_d + \sec \phi_d)} \quad \tau3 = \frac{\tan \phi_d + \sec \phi_d}{\omega_d} \quad (6)$$

charge pump current: $I_{qp} = 1$ mA

vco gain: $K_{VCO} = 2\pi \times G_{VCO}$ rad/V

PFD Frequency: $\omega_d \leq 160$ MHz

phase detector gain: $K_d = I_{qp} \div (2 \times \pi \times M)$ A/rad

An Excel spreadsheet is provided by Texas Instruments for automatically calculating the values for C1, R1 and C2.

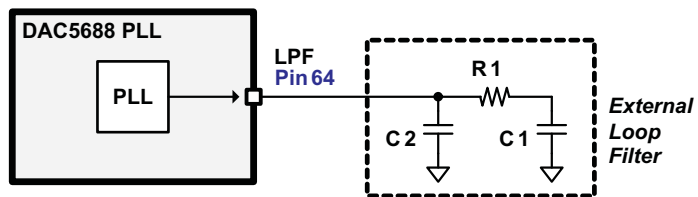

Figure 52. Recommended External Loop Filter Topology

REVISION HISTORY

NOTE: Page numbers of previous versions may differ from current version.

Changes from Revision A (March 2008) to Revision B	Page
• Changed Dual-Channel to first of title	1
• Changed sin(x)/x from upper case to lower case	1
• Added sentence to DESCRIPTION section.. "The DAC5688....multiplying PLL."	1
• Changed to join last column 2 bottom rows as one	1
• Deleted "and External" from description of pin 25	3
• Added sentence to description of pin 1	3
• Added sentence to description of pin 10,39,50,63	3
• Added text to description of TXENABLE, pin 6	3
• Deleted part of condition - Measured differential....to AVDD	5
• Changed min value from 1.71 to 1.7, max value from 2.15 to 1.9	5
• Deleted min value -0.2 and max value 0.2, and added typ value of +/-0.2	5
• Deleted "PLL = off" from 7 rows of Digital Latency description	6
• Changed test conditions "NCO off" to "NCO on"; last row of Digital Latency, 2 places	6
• Changed test conditions "NCO off" to "NCO" on next to last row of Digital Latency; and "QMC off" to "QMC on"	6
• Deleted min value -40 and max value 40 and added +/-20 to typ value in IIH row	7
• Deleted min value -40 and max value 40 and added +/-20 to typ value in IIL row	7
• Deleted 0.22xIOVDD from max value and added 0.5 in row of VOL	7
• Added 2 notes to EC digital specifications table	7
• Changed sentence in Offset Error: under TEST METHODOLOGY	14
• Added new register map table under REGISTER DESCRIPTIONS section	15
• Changed text in Register STATUS0	16
• Changed Bit 0 of Register CONFIG2 from 0 to 1	17
• Changed text of Register CONFIG3 description	17
• Changed text of Register CONFIG4 description	17
• Deleted "Reserved" explanation from Register CONFIG5 description.	18
• Changed phaseoffset(15:0) to phaseoffset(15:8) in Register CONFIG7 description	18
• Changed "Phaseadd(31:0)" to "phaseadd(31:24)" in Register CONFIG11 description	19
• Deleted explanatory "Note" from Register CONFG14 description	20
• Added text to Register CONFIG20 description.	21
• Added text to Register CONFIG21 description.	21
• Changed "Default 0x00" to "Default 0x15" for Register CONFIG23 Address	22
• Changed text in Register CONFIG23 description	22
• Changed Register CONFIG28 description from "Reserved(7:0)" to "cleared"	23
• Deleted "cleared" in description for Register CONFG28	23
• Deleted explanatory NOTE from Register CONFIG30 description.	24
• Added sentence to 1st paragraph of section "SERIAL INTERFACE" description.	25
• Changed graphic entity for Figure 22, Magnitude Spectrum for FIR1	28
• Changed text in section "Full Complex Mixer (FMIX)."	31
• Changed Q _{OUT} equation in Full Complex Mixer (FMIX) section.	31
• Changed description for section "Quadrature Modulator Correction (QMC)."	32
• Changed description for section "DAC Offset Control."	32
• Changed text in section "DUAL SYNCHRONOUS CLOCK MODE."	33
• Added text in section "DUAL CLOCK MODE."	33

- Changed [Figure 36](#) , [Figure 37](#), [Figure 38](#), caption from ".....(PLL Clock Mode)" to ".....(Dual Clock Mode)" 35
- Changed graphic entity for [Figure 40](#) 37
- Added section "PASSIVE INTERFACE TO ANALOG QUADRATURE MODULATORS." 42
- Changed text in section "RECOMMENDED STARTUP SEQUENCE " 45

Changes from Revision B (August 2010) to Revision C **Page**

- Changed cos in equation 2 to sin 31

PACKAGING INFORMATION

Orderable Device	Status (1)	Package Type	Package Drawing	Pins	Package Qty	Eco Plan (2)	Lead/Ball Finish (6)	MSL Peak Temp (3)	Op Temp (°C)	Device Marking (4/5)	Samples
DAC5688IRGCR	ACTIVE	VQFN	RGC	64	2000	Green (RoHS & no Sb/Br)	NIPDAU	Level-3-260C-168 HR	-40 to 85	DAC5688I	Samples
DAC5688IRGCT	ACTIVE	VQFN	RGC	64	250	Green (RoHS & no Sb/Br)	NIPDAU	Level-3-260C-168 HR	-40 to 85	DAC5688I	Samples

(1) The marketing status values are defined as follows:

ACTIVE: Product device recommended for new designs.

LIFEBUY: TI has announced that the device will be discontinued, and a lifetime-buy period is in effect.

NRND: Not recommended for new designs. Device is in production to support existing customers, but TI does not recommend using this part in a new design.

PREVIEW: Device has been announced but is not in production. Samples may or may not be available.

OBsolete: TI has discontinued the production of the device.

(2) **RoHS:** TI defines "RoHS" to mean semiconductor products that are compliant with the current EU RoHS requirements for all 10 RoHS substances, including the requirement that RoHS substance do not exceed 0.1% by weight in homogeneous materials. Where designed to be soldered at high temperatures, "RoHS" products are suitable for use in specified lead-free processes. TI may reference these types of products as "Pb-Free".

RoHS Exempt: TI defines "RoHS Exempt" to mean products that contain lead but are compliant with EU RoHS pursuant to a specific EU RoHS exemption.

Green: TI defines "Green" to mean the content of Chlorine (Cl) and Bromine (Br) based flame retardants meet JS709B low halogen requirements of <=1000ppm threshold. Antimony trioxide based flame retardants must also meet the <=1000ppm threshold requirement.

(3) MSL, Peak Temp. - The Moisture Sensitivity Level rating according to the JEDEC industry standard classifications, and peak solder temperature.

(4) There may be additional marking, which relates to the logo, the lot trace code information, or the environmental category on the device.

(5) Multiple Device Markings will be inside parentheses. Only one Device Marking contained in parentheses and separated by a "~" will appear on a device. If a line is indented then it is a continuation of the previous line and the two combined represent the entire Device Marking for that device.

(6) Lead/Ball Finish - Orderable Devices may have multiple material finish options. Finish options are separated by a vertical ruled line. Lead/Ball Finish values may wrap to two lines if the finish value exceeds the maximum column width.

Important Information and Disclaimer:The information provided on this page represents TI's knowledge and belief as of the date that it is provided. TI bases its knowledge and belief on information provided by third parties, and makes no representation or warranty as to the accuracy of such information. Efforts are underway to better integrate information from third parties. TI has taken and continues to take reasonable steps to provide representative and accurate information but may not have conducted destructive testing or chemical analysis on incoming materials and chemicals. TI and TI suppliers consider certain information to be proprietary, and thus CAS numbers and other limited information may not be available for release.

In no event shall TI's liability arising out of such information exceed the total purchase price of the TI part(s) at issue in this document sold by TI to Customer on an annual basis.

TAPE AND REEL INFORMATION

QUADRANT ASSIGNMENTS FOR PIN 1 ORIENTATION IN TAPE

*All dimensions are nominal

Device	Package Type	Package Drawing	Pins	SPQ	Reel Diameter (mm)	Reel Width W1 (mm)	A0 (mm)	B0 (mm)	K0 (mm)	P1 (mm)	W (mm)	Pin1 Quadrant
DAC5688IRGCR	VQFN	RGC	64	2000	330.0	16.4	9.3	9.3	1.5	12.0	16.0	Q2
DAC5688IRGCT	VQFN	RGC	64	250	330.0	16.4	9.3	9.3	1.5	12.0	16.0	Q2

TAPE AND REEL BOX DIMENSIONS



*All dimensions are nominal

Device	Package Type	Package Drawing	Pins	SPQ	Length (mm)	Width (mm)	Height (mm)
DAC5688IRGCR	VQFN	RGC	64	2000	367.0	367.0	38.0
DAC5688IRGCT	VQFN	RGC	64	250	367.0	367.0	38.0

GENERIC PACKAGE VIEW

RGC 64

VQFN - 1 mm max height

9 x 9, 0.5 mm pitch

PLASTIC QUAD FLATPACK - NO LEAD

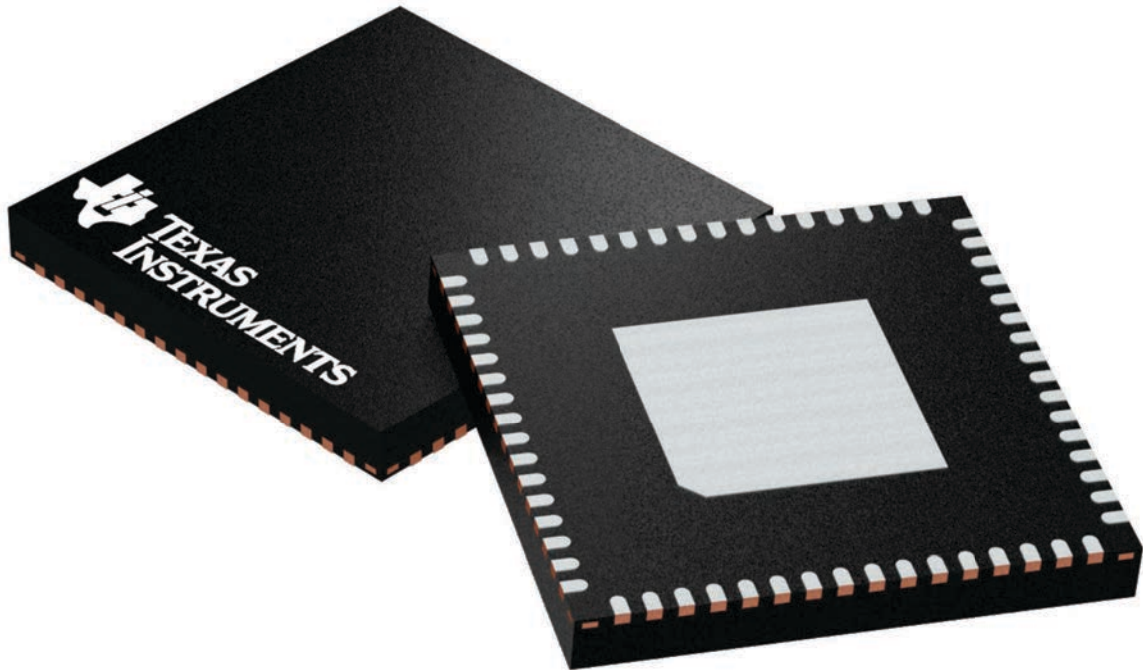

Images above are just a representation of the package family, actual package may vary.
Refer to the product data sheet for package details.

4224597/A

RGC0064H

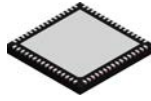

PACKAGE OUTLINE

VQFN - 1 mm max height

PLASTIC QUAD FLATPACK - NO LEAD

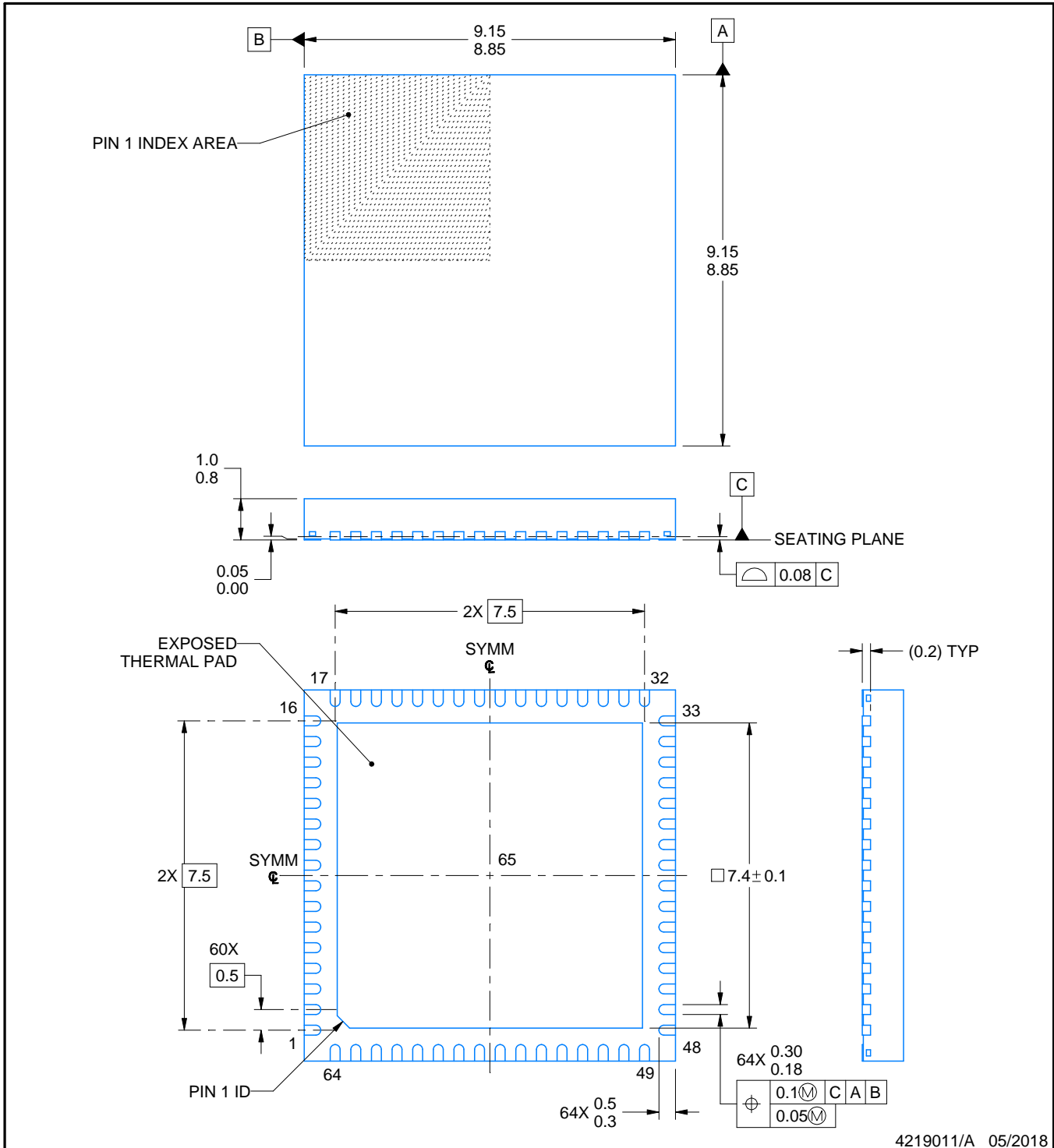

4219011/A 05/2018

NOTES:

1. All linear dimensions are in millimeters. Any dimensions in parenthesis are for reference only. Dimensioning and tolerancing per ASME Y14.5M.
2. This drawing is subject to change without notice.
3. The package thermal pad must be soldered to the printed circuit board for thermal and mechanical performance.

EXAMPLE BOARD LAYOUT

RGC0064H

VQFN - 1 mm max height

PLASTIC QUAD FLATPACK - NO LEAD

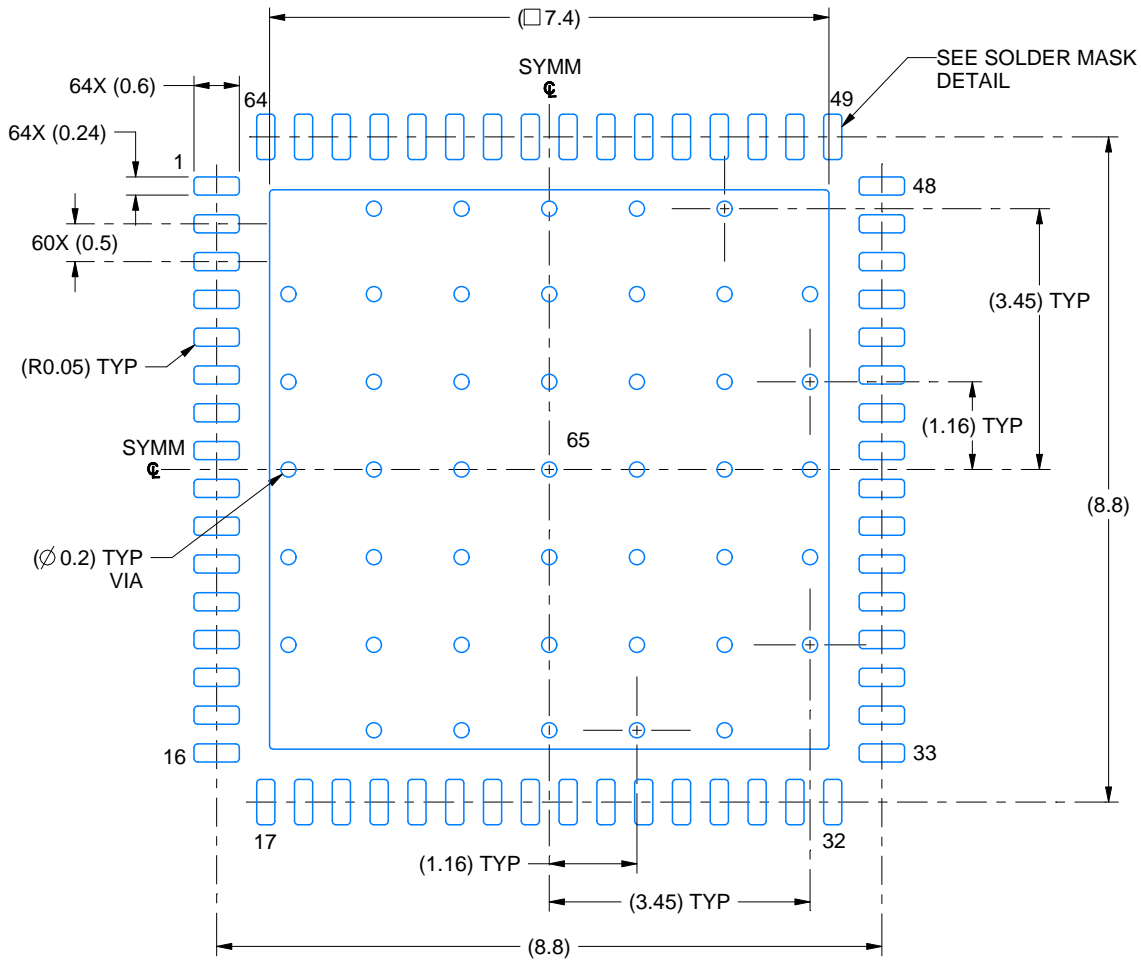

LAND PATTERN EXAMPLE
EXPOSED METAL SHOWN
SCALE: 10X

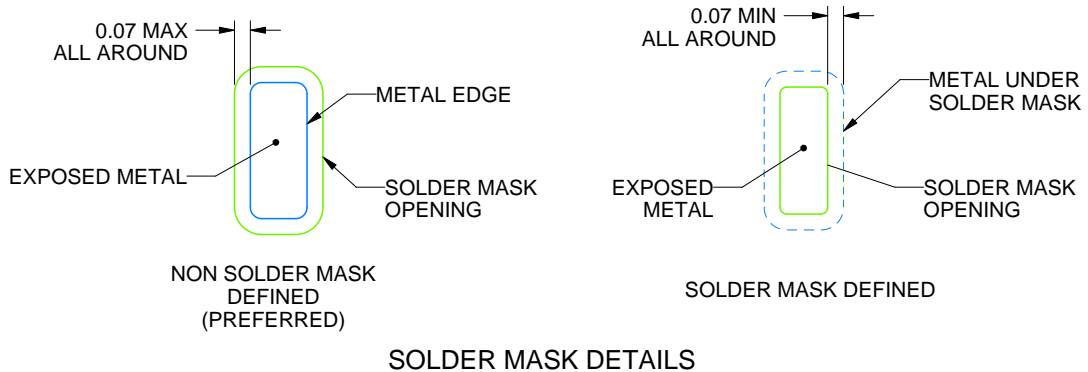

4219011/A 05/2018

NOTES: (continued)

- This package is designed to be soldered to a thermal pad on the board. For more information, see Texas Instruments literature number SLUA271 (www.ti.com/lit/sluea271).
- Vias are optional depending on application, refer to device data sheet. If any vias are implemented, refer to their locations shown on this view. It is recommended that vias under paste be filled, plugged or tented.

EXAMPLE STENCIL DESIGN

RGC0064H

VQFN - 1 mm max height

PLASTIC QUAD FLATPACK - NO LEAD

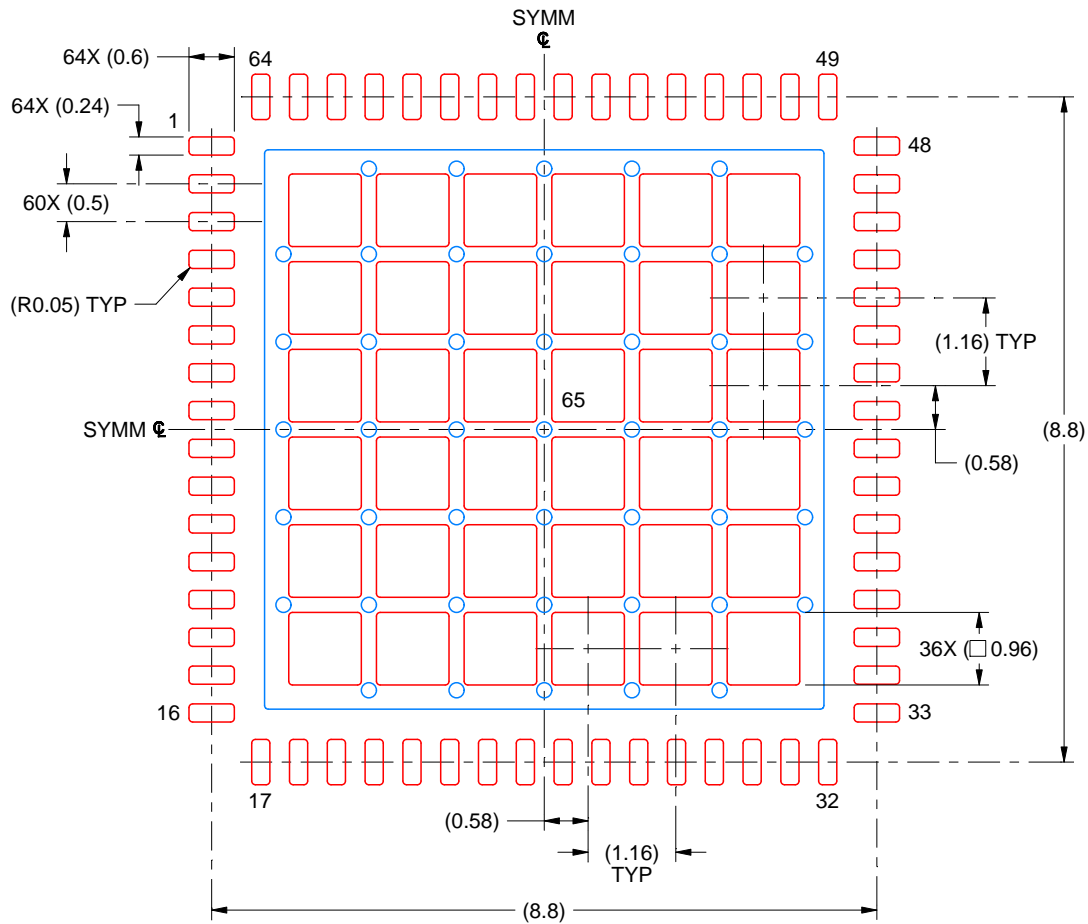

SOLDER PASTE EXAMPLE
BASED ON 0.125 MM THICK STENCIL
SCALE: 10X

EXPOSED PAD 65
61% PRINTED SOLDER COVERAGE BY AREA UNDER PACKAGE

4219011/A 05/2018

NOTES: (continued)

6. Laser cutting apertures with trapezoidal walls and rounded corners may offer better paste release. IPC-7525 may have alternate design recommendations.

IMPORTANT NOTICE AND DISCLAIMER

TI PROVIDES TECHNICAL AND RELIABILITY DATA (INCLUDING DATASHEETS), DESIGN RESOURCES (INCLUDING REFERENCE DESIGNS), APPLICATION OR OTHER DESIGN ADVICE, WEB TOOLS, SAFETY INFORMATION, AND OTHER RESOURCES "AS IS" AND WITH ALL FAULTS, AND DISCLAIMS ALL WARRANTIES, EXPRESS AND IMPLIED, INCLUDING WITHOUT LIMITATION ANY IMPLIED WARRANTIES OF MERCHANTABILITY, FITNESS FOR A PARTICULAR PURPOSE OR NON-INFRINGEMENT OF THIRD PARTY INTELLECTUAL PROPERTY RIGHTS.

These resources are intended for skilled developers designing with TI products. You are solely responsible for (1) selecting the appropriate TI products for your application, (2) designing, validating and testing your application, and (3) ensuring your application meets applicable standards, and any other safety, security, or other requirements. These resources are subject to change without notice. TI grants you permission to use these resources only for development of an application that uses the TI products described in the resource. Other reproduction and display of these resources is prohibited. No license is granted to any other TI intellectual property right or to any third party intellectual property right. TI disclaims responsibility for, and you will fully indemnify TI and its representatives against, any claims, damages, costs, losses, and liabilities arising out of your use of these resources.

TI's products are provided subject to TI's Terms of Sale (www.ti.com/legal/termsofsale.html) or other applicable terms available either on ti.com or provided in conjunction with such TI products. TI's provision of these resources does not expand or otherwise alter TI's applicable warranties or warranty disclaimers for TI products.

Mailing Address: Texas Instruments, Post Office Box 655303, Dallas, Texas 75265
Copyright © 2020, Texas Instruments Incorporated