

SYMBOL DEFINITION		MISSING SYMBOLS	
A DIMENSION WITHOUT AN INSPECTION REPORT SYMBOL DOES NOT REQUIRE INSPECTION. IT MAY BE CONTROLLED ON THE INDIVIDUAL COMPONENT DRAWING.	TOTAL NO OF INSPECTIONS REQUIRED	5	7 11
	LAST NO. USED		19

DWG STATUS				REVISION HISTORY				AUTH		DR		APVD	
DATE	STG	REV	N/P	CHG	ZONE								
31MR09	R	01	-	-		ALL PARTS: RELEASED (13726146 WAS PE180265, 13726147 WAS PE179543, 13726148 WAS PE179542)	407686	MM	MM	RJB			
03AP09	R	02	-	-		ALL PARTS: REDUCED CONTACT BEAM LENGTH; ADDED 1.45 ± 0.05, 5.05 DIMENSIONS AND NOTE 6	407762	MM	MM	RJB			
17AP09	R	03	-	-		ALL PARTS: ADDED 0.42 ± 0.05 DIMENSION; REVISED NOTE 3 TO STATE 7.5 AMPS	407841	MM	MM	RJB			
23JUN09	R	04	-	-		ALL PARTS: REVISED TOLERANCES ON TOD	408274	MM	MM	RJB			
19AU09	R	05	-	-		ALL PARTS: REVISED TOLERANCES ON TOD	408676	MM	MM	RJB			
27OC09	R	06	-	-		ALL PARTS: REVISED NOTE 6; ADDED NOTE 7	409339	MM	MM	RJB			
15MR10	R	07	-	-		ALL PARTS: REVISED NOTE 6; ADDED CABLE CORE STRANDS LABEL (#19); 1.75 DIMENSION (#1) WAS 1.7	410284	MM	MM	RJB			
02AU10	R	08	-	-		ALL PARTS: ADDED PLATING TYPE INFORMATION, NOTE 8; REVISED NOTE 2 AND MATERIAL SPECIFICATION.	411468	MM	MM	RJB			
29SE10	R	09	-	-		ALL PARTS - REVISED "PARTS MEET" & "PLATING TYPE" NOTES	412049	ARC	ARC	RJB			
02NO10	R	10	-	-		ALL PARTS - UPDATED PDM ATTRIBUTES	412391	ACR	JAA	RJB			
10DE10	R	11	-	-		ALL PARTS - UPDATED DRAWING NAME	412864	MAL	MAL	RJB			
15MR11	R	12	-	-		ALL PARTS - 2.06 +0.04/-0.05 WAS 2.06 ± 0.04	413657	DMC	DMC	RJB			
25AP11	R	13	-	-		ALL PARTS - ADDED CONTACT PLATING & CONTACT PLATING I.D. COLUMNS ON CHART	413975	ARC	ARC	RJB			
26NO12	R	14	-	-		ALL PARTS - UPDATED PDM ATTRIBUTES	420528	CER	CER	RBS			
28NO12	R	15	-	-		13726148 - CABLE SIZE WAS 0.75 - 0.8; 13726146 - CABLE DIA WAS 0.81 - 1.1	420596	CER	CER	RBS			

3 1.6 ± 0.05  
MUST BE MAINTAINED FOR ENTIRE 6.5mm TERMINAL BOX LENGTH

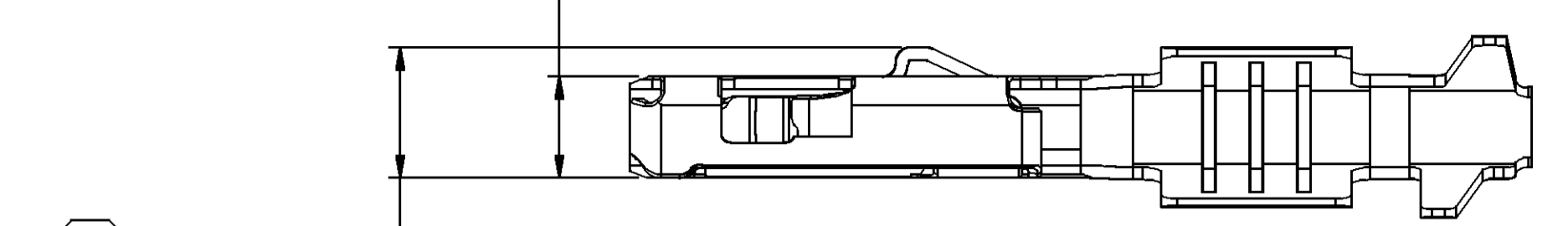

2 +0.04  
2.06 -0.05

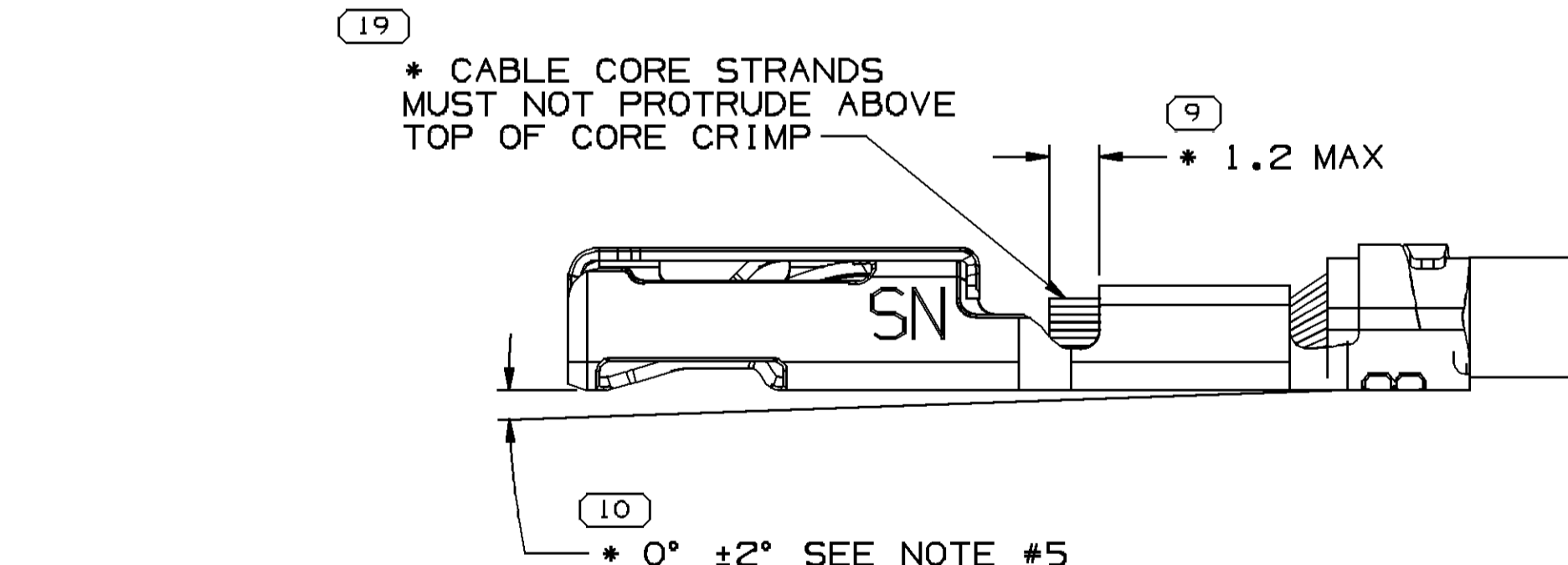
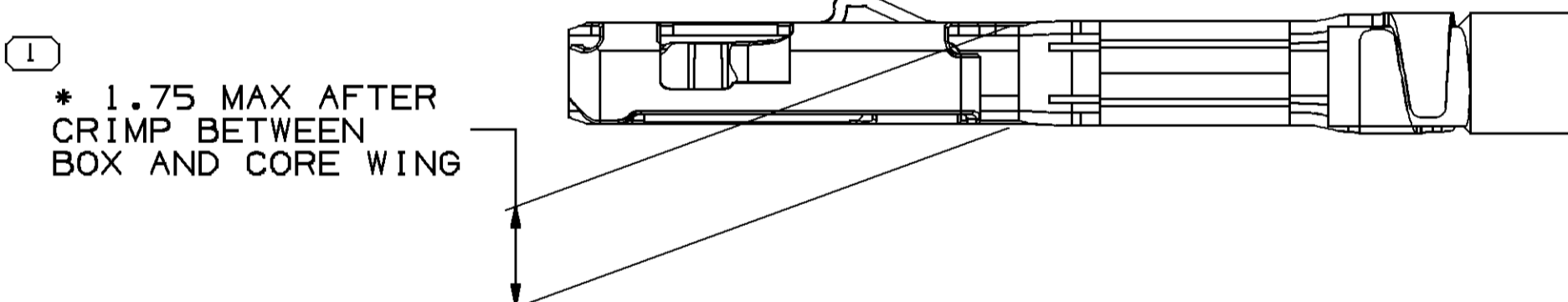
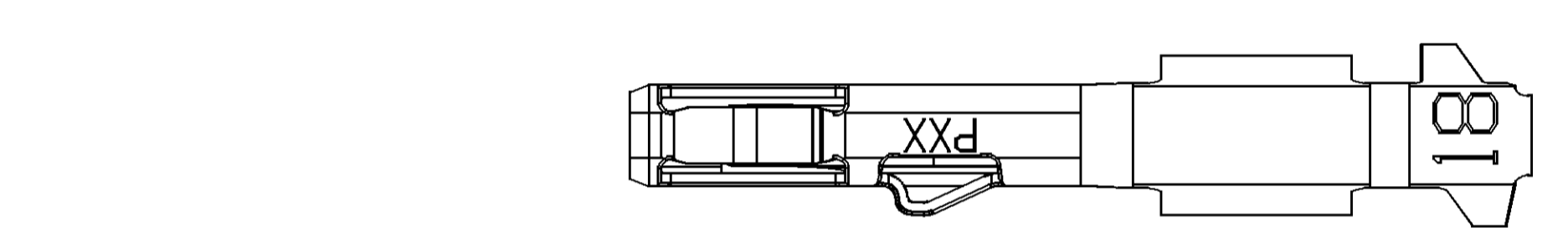
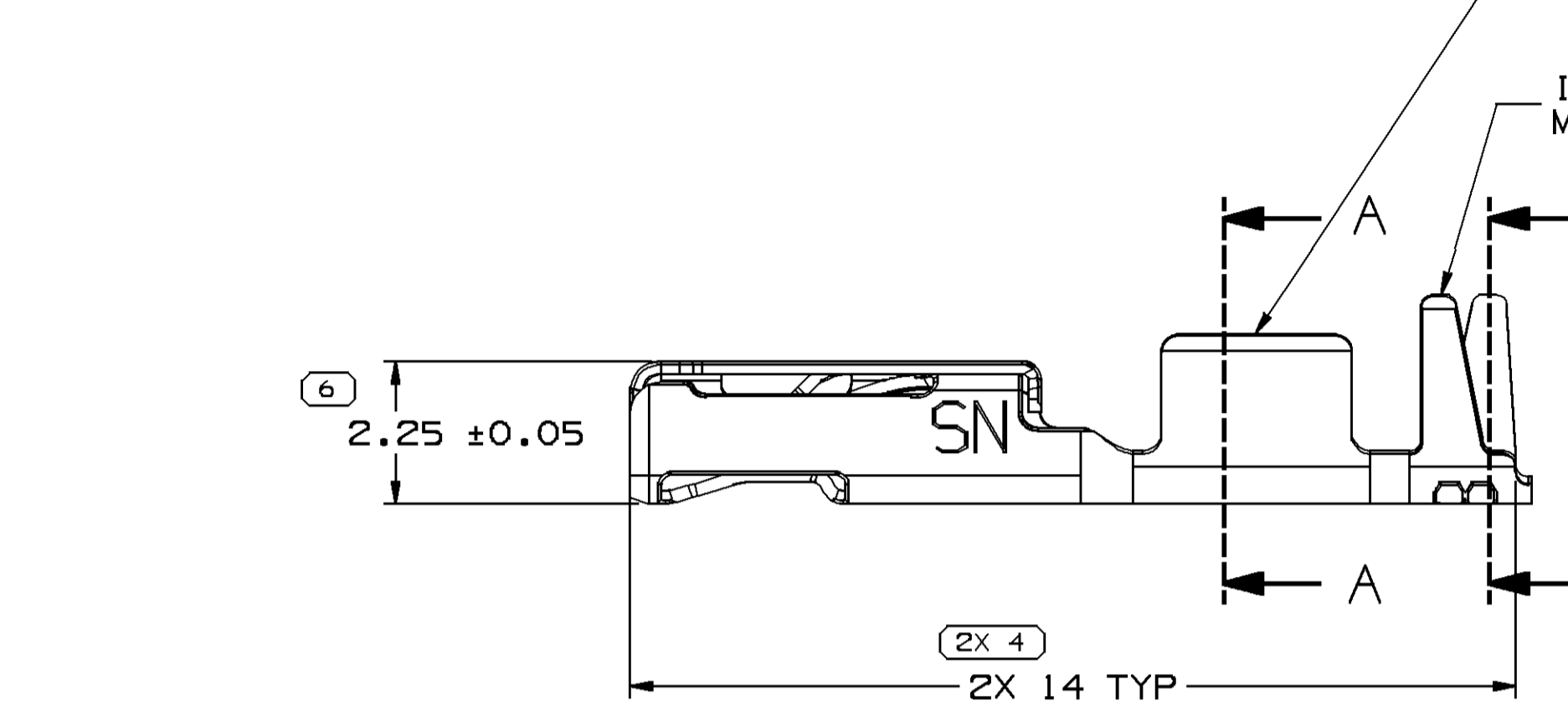

10 \* 0° ± 2° SEE NOTE #5  
TERMINAL, CABLE CRIMP ALIGNMENT & POSITION

CONDUCTOR WINGS FOR (SEE CHART) MM<sup>2</sup> CABLE  
INSULATION WINGS FOR (SEE CHART) MAX INSULATION DIA

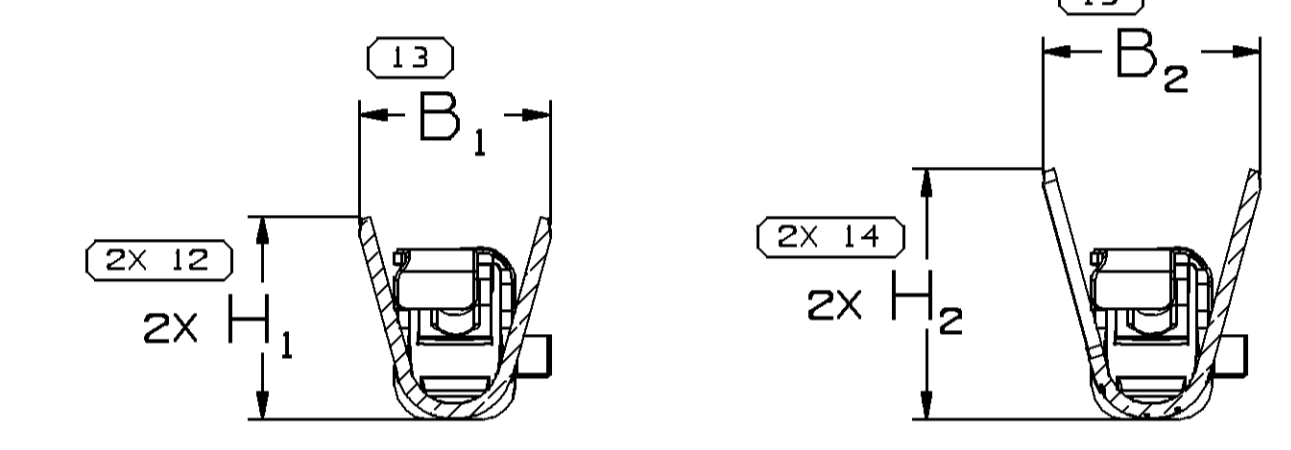
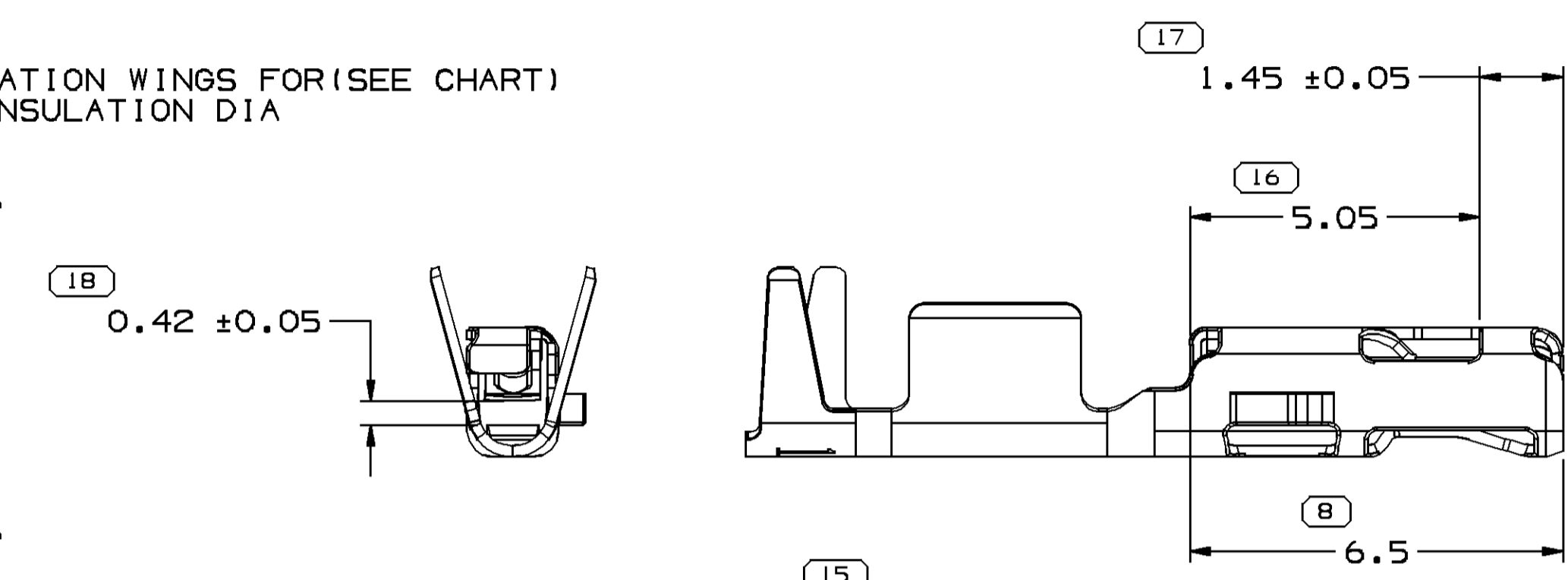

- NOTES
- UNLESS OTHERWISE SPECIFIED AND/OR INDICATED:  
DIMENSIONS ARE TO FACE OF VIEW SHOWN AND AUTOMATICALLY ROUNDED BY COMPUTER FOR INSPECTION (SEE MATH MODEL FOR PRECISE DIMENSIONS). FOR ALL OTHER DIMENSIONS NOT SHOWN BUT REQUIRED FOR TOOL BUILD, SEE MATH MODEL FOR PRECISE TOOL PATH DATA.
  - RECOMMENDED MATING BLADE THICKNESS 0.64 ± 0.03mm  
RECOMMENDED MATING BLADE WIDTH NOT TO EXCEED 1mm AND NO LESS THAN 0.6mm. SEE USCAR EWCAP-001 (0.64 PIN) FOR OTHER MATING BLADE REQUIREMENTS.
  - MAXIMUM CURRENT CAPACITY IS 7.5 AMPS WITH 0.8mm<sup>2</sup> COPPER CABLE.
  - \* DENOTES DIMENSIONS MADE AT CUT-OFF AND CRIMP DIE
  - PLUS ANGLE IS WING BOTTOM SURFACE ROTATED COUNTERCLOCKWISE AGAINST THE BOX BOTTOM SURFACE.
  - PARTS MEET THE PERFORMANCE REQUIREMENTS OF 6MW3191 DEC 2007 REVISION FOR THE FOLLOWING CLASSIFICATIONS:  
TEMPERATURE CLASS 3 (-40°C TO 125°C)  
VIBRATION CLASS 1 (ON BODY OR CHASSIS)  
SEALING CLASS 1 (UNSEALED) FOR GAGE I.D. 25  
SEALING CLASS 2 & 3 (SEALED - CONNECTOR DEPENDENT) FOR GAGE I.D. 18 AND 21
  - DO NOT PROBE, TEST OR OTHERWISE CONTACT THE INTERIOR REGION (THE SPRING OR ANY MOVING PART) OF THIS TERMINAL. SEVERE DAMAGE CAN OCCUR, COMPROMISING THE PERFORMANCE OF THE ELECTRICAL INTERFACE.
  - PLATING TYPE:  
1. REFLOW TIN 1.9 - 3.3 MICROMETERS THICK OVER COPPER  
UNDERPLATE 0.5 - 1.0 MICROMETERS THICK  
PLATING TYPE INFORMATION SHOWN ABOVE IS REFERENCE ONLY:  
PLATING REQUIREMENTS ARE CONTAINED IN APPLICABLE MATERIAL SPECIFICATION.

PART NUMBER	REV	N/P	STATUS	MATERIAL DESCRIPTION	CONTACT AREA PLATING TYPE (SEE NOTE 8)	CRIMP AREA PLATING TYPE (SEE NOTE 8)	CONTACT PLATING	CONTACT PLATING I.D.	I.D.	CABLE SIZE (mm <sup>2</sup> )	CABLE DIAMETER	B <sub>1</sub> ± 0.15	B <sub>2</sub> ± 0.3	(H <sub>1</sub> )	(H <sub>2</sub> )
13726148	02	AN	-	COPPER ALLOY	I	I	TIN	SN	18	0.8	1.7 - 1.9	2.52	2.88	2.68	3.31
13726147	02	AM	-	COPPER ALLOY	I	I	TIN	SN	21	0.35 - 0.5	1.47 - 1.83	2.04	2.8	2.06	3.17
13726146	02	AN	-	COPPER ALLOY	I	I	TIN	SN	25	0.13 - 0.22	0.83 - 1.1	1.54	1.74	1.56	1.77

DIMENSIONAL RANGE (MM)		CHART	D
FROM	0	> 12	
TO	12		

TOLERANCE UNLESS OTHERWISE SPECIFIED  
± 0.1 ± 0.2  
ANGULAR TOLERANCE ± 2°

LINE DRAWN THROUGH A PART NUMBER INDICATES THAT PHYSICAL PARTS ARE NOT AVAILABLE FOR ORDERING.	
PART NUMBERS THAT DO NOT HAVE A LINE PRESENT INDICATE THAT PHYSICAL PARTS ARE AVAILABLE FOR ORDERING.	
CONTACT DELPHI SALES TO ASSURE AVAILABILITY OF PARTS.	
UNLESS OTHERWISE SPECIFIED THIS DOCUMENT IS IN ACCORDANCE WITH ASME Y14.5M-1994 AS MODIFIED BY THE GM GLOBAL DIMENSIONING AND TOLERANCING ADDENDUM-2001. SEPARATE PATTERNS OF FEATURES MAY BE GAGED SEPARATELY REGARDLESS OF DATUM REFERENCES.	
ALL DIMENSIONS ARE IN MILLIMETERS	
THIRD ANGLE PROJECTION	DO NOT SCALE
USE DATA	NX

**DELPHI**  
DELPHI PACKARD ELECTRICAL/ELECTRONIC ARCHITECTURE  
WARREN, OH  
COPYRIGHT 2009 DELPHI CORPORATION AND/OR ITS AFFILIATES. ALL RIGHTS RESERVED.

THIS DRAWING IS THE PROPERTY OF DELPHI CORPORATION AND CONTAINS DELPHI CONFIDENTIAL INFORMATION. THE REPRODUCTION, DISTRIBUTION AND UTILIZATION OF THIS DOCUMENT OR ITS RELATED CAD MATH DATA, AS WELL AS COMMUNICATION OF ANY CONTENT TO OTHERS, WITHOUT EXPRESS AUTHORIZATION, IS PROHIBITED.

DR	DATE
APVD1 M McCALL	31MR09
APVD2 M McCALL	31MR09
APVD3 RAYMOND J. BLASKO	31MR09
APVD4	
APVD5	

SUBSTANCES OF CONCERN AND RECYCLED CONTENT PER DELPHI 10949001

MATERIAL SEE CHART

DRAWING NAME  
TAXI TERM F OCS 0.64 ISM

DRAWING NUMBER  
13756466

SIZE	SCALE	FRAME NO	SHEET NO	STG	REV	N/P
A1	10:1	1 OF 1	1 OF 1	R	15	-

# Mouser Electronics

Authorized Distributor

Click to View Pricing, Inventory, Delivery & Lifecycle Information:

[Aptiv:](#)

[13726148-L](#) [13726147-L](#) [13726146-L](#)