

SYMBOL DEFINITION		MISSING SYMBOLS	
A DIMENSION WITHOUT AN INSPECTION REPORT SYMBOL ( ) DOES NOT REQUIRE INSPECTION. IT MAY BE CONTROLLED ON THE INDIVIDUAL COMPONENT DRAWING.	TOTAL NO OF INSPECTIONS REQUIRED	NO MISSING SYMBOL NUMBER	57
	LAST NO. USED		22

DWG STATUS					ZONE	REVISION HISTORY	AUTH	DR	APVD1	APVD2
DATE	STG	REV	N/P	CHG						
28MR01	R	001	-	-		15355357 WAS SEPERATE DRAWING, 15410207 RELEASED	208291	CJC	CJC	CAM
29N001	R	002	-	-		UPDATED TOLERANCES	217960	CJC	CJC	CAM
17SE03	R	03	-	-		ALL PARTS - REVISED NOTES AND MAT'L SPEC WAS R0071790	246025	TLD	TLD	MP

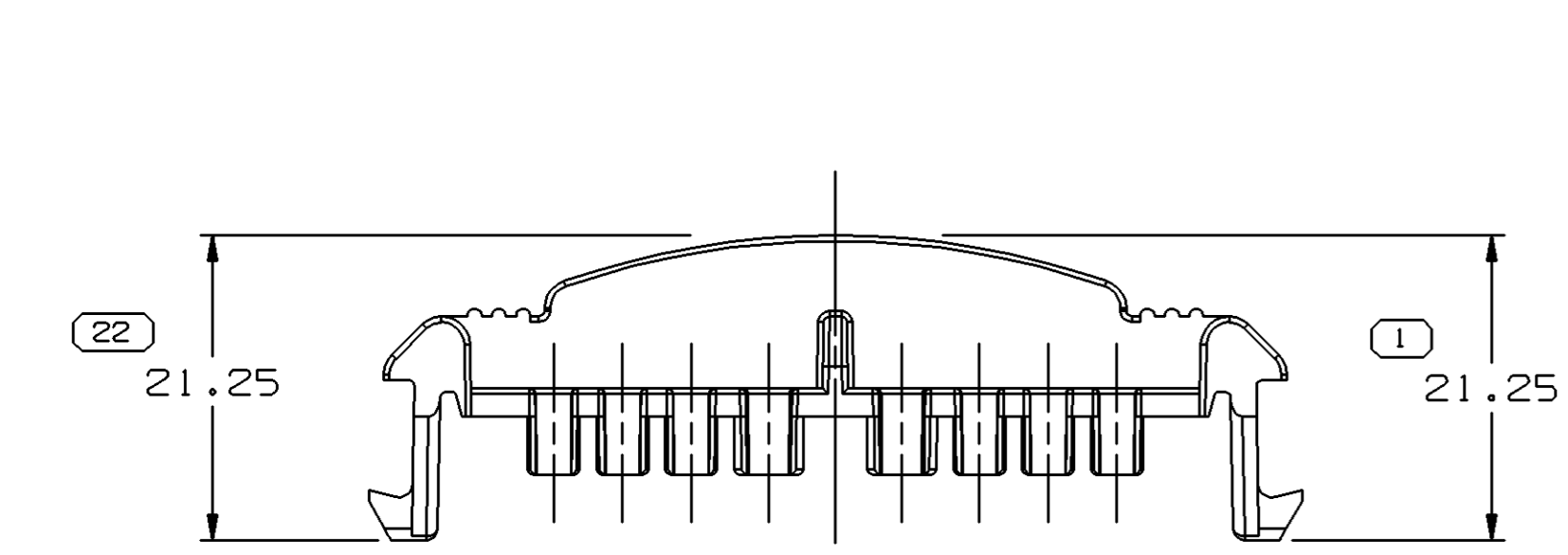

TYPE 101

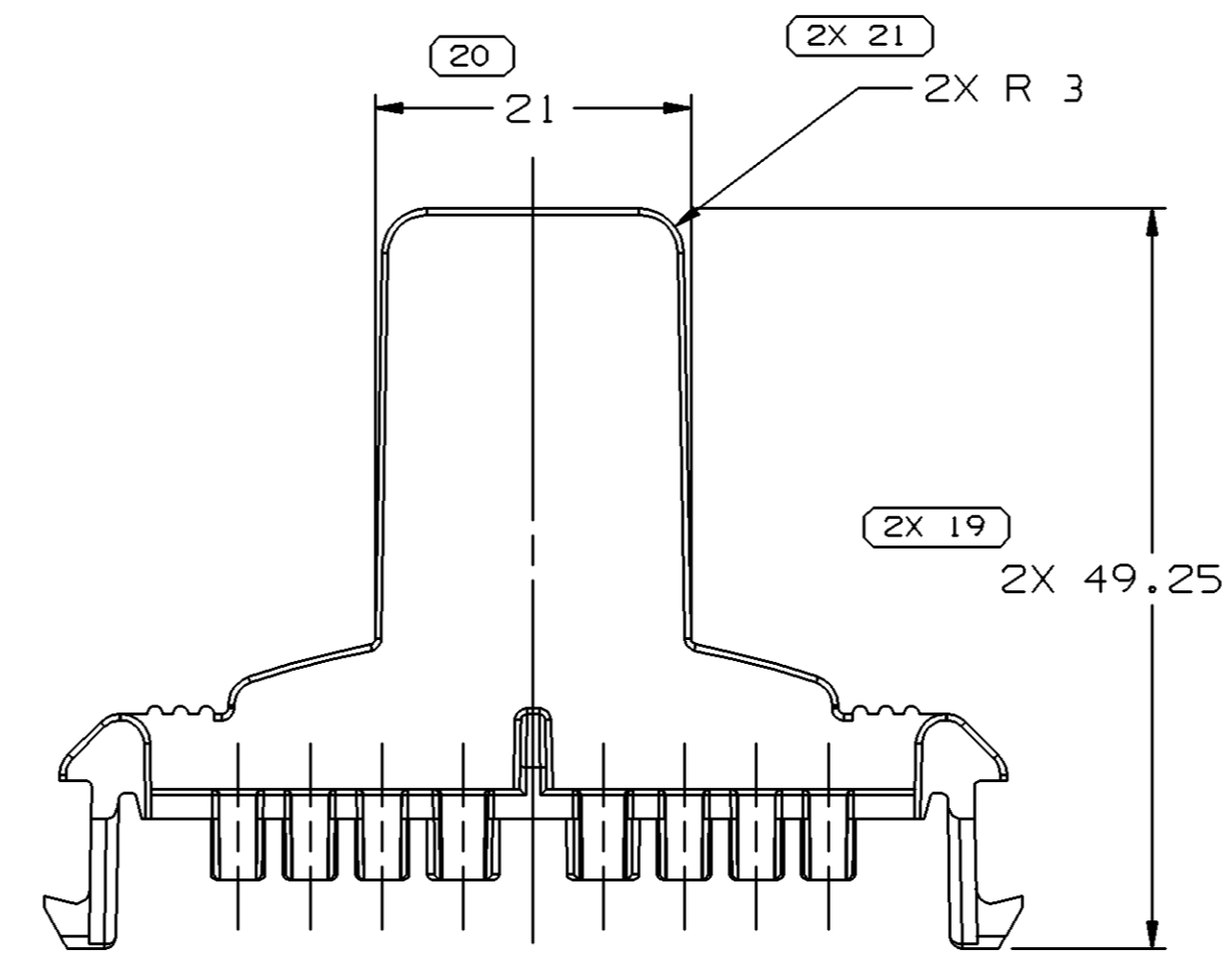

TYPE 102  
SAME AS TYPE 101  
EXCEPT AS SHOWN

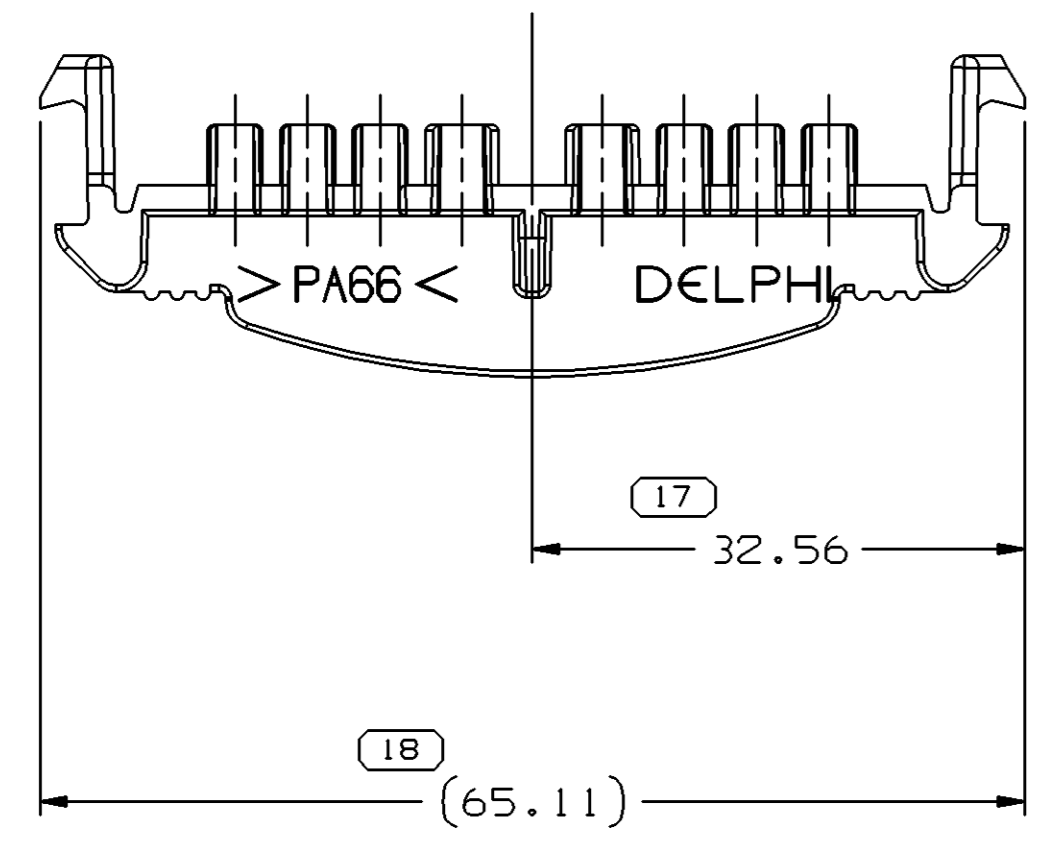
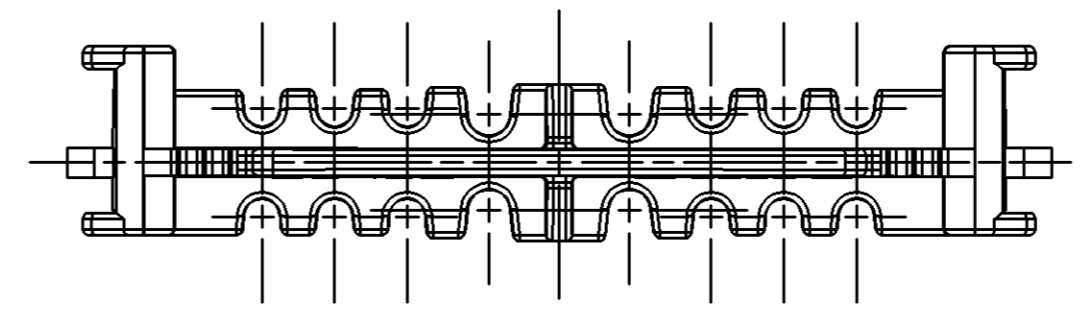
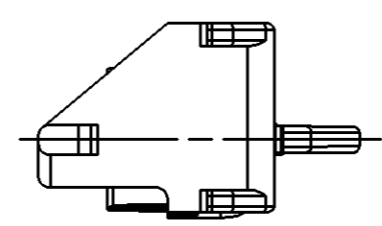
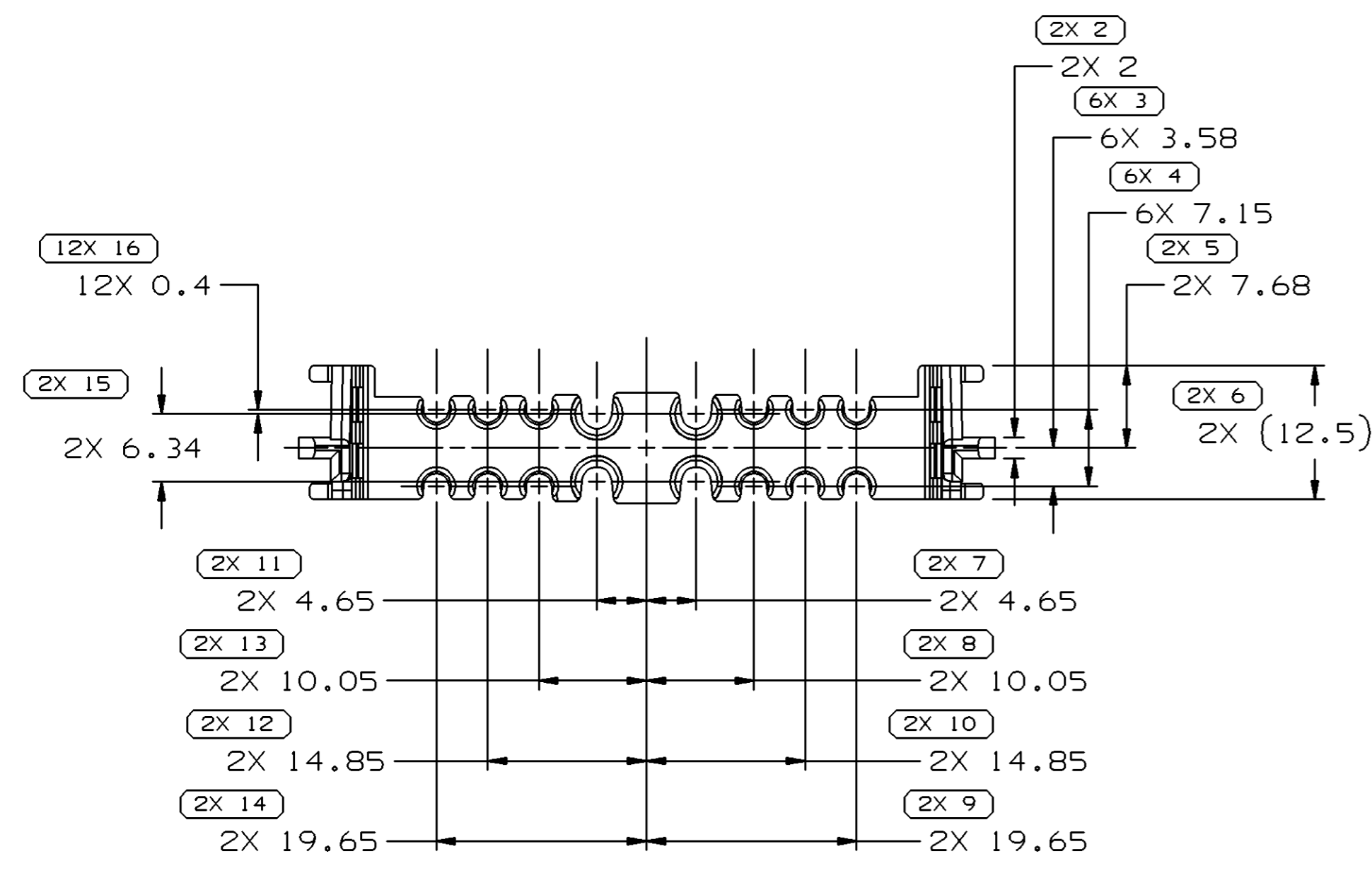

NOTES

- UNLESS OTHERWISE SPECIFIED AND/OR INDICATED: DIMENSIONS ARE TO FACE OF VIEW SHOWN AND AUTOMATICALLY ROUNDED BY COMPUTER FOR INSPECTION (SEE MATH MODEL FOR PRECISE DIMENSIONS). FOR ALL OTHER DIMENSIONS NOT SHOWN BUT REQUIRED FOR TOOL BUILD, SEE MATH MODEL FOR PRECISE TOOL PATH DATA.
- MATERIAL RECYCLING CODE PER ISO 11469. (2.3)X(0.1) RAISED CHARACTERS AS SHOWN TO BE LOCATED ON ANY EXTERIOR SURFACE. OPTIONAL CONSTRUCTION TO BE NO MATERIAL RECYCLING CODE.
- MATING COMPONENTS OR EQUIVALENT: CONNECTOR 15336173
- (2.3)X(0.1) RAISED DELPHI CORPORATE BRAND TO BE LOCATED ON ANY EXTERIOR SURFACE, PREFERABLY VISIBLE AT FINAL ASSEMBLY. OPTIONAL CONSTRUCTION TO BE "PED" OR NO LOGO.
- THIS PART DOES NOT FALL IN TO THE CATEGORY OF AN APPEARANCE ITEM. MINOR SURFACE IMPERFECTIONS SUCH AS FLOW LINES, EJECTOR PIN MARKS, KNIT LINES, WELD MARKS AND GATE MARKINGS ARE PERMITTED.
- TPA IS DESIGNED FOR USE WITH 2-R1B CABLE SEALS AS SHOWN ON 12191227.

15410207	R	001	AB		102	M3592008 PA66 HS IM BLU	3.585
15355357	R	002	AC		101	M3592008 PA66 HS IM BLU	2.758
PART NO	STG	REV	N/P	STATUS	TYPE	MATERIAL SPECIFICATION AND COLOR	VOL CM <sup>3</sup>

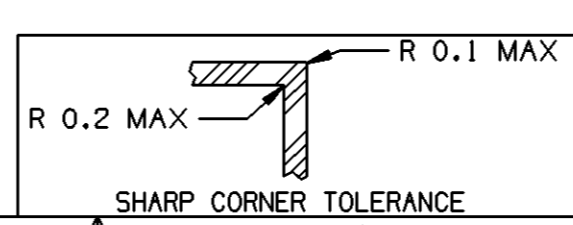

DIMENSIONAL RANGE (MM)		TOLERANCE UNLESS OTHERWISE SPECIFIED	
FROM	TO		
> 0	> 20	±0.15	±0.2
> 20	> 30	±0.3	±0.4
> 30	> 70	±0.4	±0.5
> 70	> 100	±0.5	±0.6
> 100	> 150	±0.6	±0.8
> 150	> 200	±1	±1.2
> 200	> 250		
> 250	> 300		
> 300	> 400		

DWG TYPE		PART DRAWING	
STYLE			
VOLUME (CM <sup>3</sup> )		DISTR CODE	
SEE CHART		D	
ROUTING			
6900			
UNLESS OTHERWISE SPECIFIED			
THIS DOCUMENT IS IN ACCORDANCE WITH ASME Y14.5M-1994 AS AMENDED BY THE GM GLOBAL DIMENSIONING AND TOLERANCING ADDENDUM-2001. SEPARATE PATTERNS OF FEATURES MAY BE GAGED SEPARATELY REGARDLESS OF DATUM REFERENCES.			
ALL DIMENSIONS ARE IN MILLIMETERS			
REFERENCE			
THIRD ANGLE PROJECTION		DO NOT SCALE	
USE MATH DATA		UNIGRAPHICS	

**DELPHI**  
DELPHI PACKARD ELECTRIC SYSTEMS  
WARREN, OH

DATE	
DR	CRAIG COGGINS
APVD1	CRAIG COGGINS
APVD2	CRAIG COGGINS
APVD3	COURTNEY MANSKY
APVD4	
APVD5	

DATE: 28MR01  
28MR01  
30MR01  
04AP01

SUBSTANCES OF CONCERN AND RECYCLED CONTENT PER DELPHI 10949001

MATERIAL SEE CHART

DRAWING NAME  
TAXI LOCK TPA GT 150 280 16

DRAWING NUMBER  
15410211

SIZE	SCALE	FRAME NO	SHEET NO	STG	REV	N/P
A1	2:1	1 OF 1	1 OF 1	R	03	-

# Mouser Electronics

Authorized Distributor

Click to View Pricing, Inventory, Delivery & Lifecycle Information:

[Aptiv:](#)

[15355357](#)