

**CHIP EMIFIL®CHIP 3-TERMINAL CAPACITOR FOR AUTOMOTIVE
NFM21HC Series**

Reference Sheet

1.Scope

This product specification is applied to Chip EMIFIL®Chip 3-terminal Capacitor used for Automotive Electronic equipment.

2.Reference PART No. List

	Customer PART NO.	MURATA PART NO.
1		NFM21HC101U1H3D
2		NFM21HC102R1H3D
3		NFM21HC104R1A3D
4		NFM21HC105R1C3D
5		NFM21HC220U1H3D
6		NFM21HC221R1H3D
7		NFM21HC222R1H3D
8		NFM21HC223R1H3D
9		NFM21HC224R1A3D
10		NFM21HC470U1H3D
11		NFM21HC471R1H3D
12		NFM21HC474R1A3D

3.MURATA Part NO. System

(Ex.)

NFM	21	HC	101	U	1H	3	D
-----	----	----	-----	---	----	---	---

(1)LW Dimensions (2)Features (3)Nominal Capacitance (4) Characteristics (5)DC Rated Voltage (6)Electrode (7)Packaging Code

4. Type & Dimensions

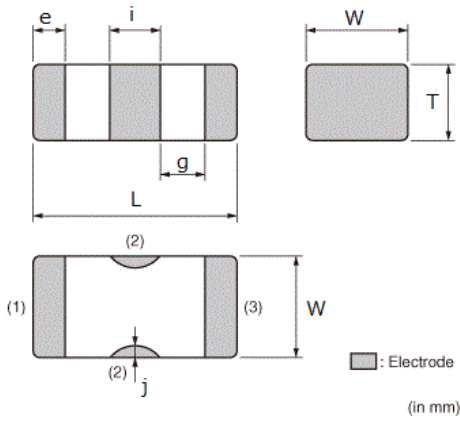

(Unit:mm)

	MURATA PART NO.	(1)-1 L	(1)-2 W	T	e	g
		i	j			
1	NFM21HC101U1H3D	2.0±0.2	1.25±0.1	0.85±0.1	0.3±0.2	0.2 min.
		0.6±0.2	0.2+0.2/-0.1			
2	NFM21HC102R1H3D	2.0±0.2	1.25±0.1	0.85±0.1	0.3±0.2	0.2 min.
		0.6±0.2	0.2+0.2/-0.1			
3	NFM21HC104R1A3D	2.0±0.2	1.25±0.1	0.85±0.1	0.3±0.2	0.2 min.
		0.6±0.2	0.2+0.2/-0.1			
4	NFM21HC105R1C3D	2.0±0.2	1.25±0.1	0.85±0.1	0.3±0.2	0.2 min.
		0.6±0.2	0.2+0.2/-0.1			
5	NFM21HC220U1H3D	2.0±0.2	1.25±0.1	0.85±0.1	0.3±0.2	0.2 min.
		0.6±0.2	0.2+0.2/-0.1			
6	NFM21HC221R1H3D	2.0±0.2	1.25±0.1	0.85±0.1	0.3±0.2	0.2 min.
		0.6±0.2	0.2+0.2/-0.1			
7	NFM21HC222R1H3D	2.0±0.2	1.25±0.1	0.85±0.1	0.3±0.2	0.2 min.
		0.6±0.2	0.2+0.2/-0.1			
8	NFM21HC223R1H3D	2.0±0.2	1.25±0.1	0.85±0.1	0.3±0.2	0.2 min.
		0.6±0.2	0.2+0.2/-0.1			
9	NFM21HC224R1A3D	2.0±0.2	1.25±0.1	0.85±0.1	0.3±0.2	0.2 min.
		0.6±0.2	0.2+0.2/-0.1			
10	NFM21HC470U1H3D	2.0±0.2	1.25±0.1	0.85±0.1	0.3±0.2	0.2 min.
		0.6±0.2	0.2+0.2/-0.1			
11	NFM21HC471R1H3D	2.0±0.2	1.25±0.1	0.85±0.1	0.3±0.2	0.2 min.
		0.6±0.2	0.2+0.2/-0.1			
12	NFM21HC474R1A3D	2.0±0.2	1.25±0.1	0.85±0.1	0.3±0.2	0.2 min.
		0.6±0.2	0.2+0.2/-0.1			

a)Equivalent Circuit

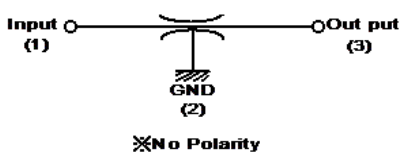

5. Rated value

	MURATA PART NO.	(3) Nominal Capacitance	Capacitance Tolerance	(5) Rated Voltage	Rated Current (mA)	DC Resistance	Insulation Resistance	Specifications and Test Methods (Operating / Storage Temp. Range)
1	NFM21HC101U1H3D	100 pF	±20 %	DC 50 V	700mA(DC)	0.3Ωmax.	1000MΩmin	Section 7.1 (-55 to 125 °C / -55 to 125 °C)
2	NFM21HC102R1H3D	1000 pF	±20 %	DC 50 V	1A(DC)	0.3Ωmax.	1000MΩmin	Section 7.1 (-55 to 125 °C / -55 to 125 °C)
3	NFM21HC104R1A3D	0.1 uF	±20 %	DC 10 V	2A(DC)	0.03Ωmax.	1000MΩmin	Section 7.1 (-55 to 125 °C / -55 to 125 °C)
4	NFM21HC105R1C3D	1 uF	±20 %	DC 16 V	4A(DC)	0.02Ωmax.	500MΩmin.	Section 7.1 (-55 to 125 °C / -55 to 125 °C)
5	NFM21HC220U1H3D	22 pF	±20 %	DC 50 V	700mA(DC)	0.3Ωmax.	1000MΩmin	Section 7.1 (-55 to 125 °C / -55 to 125 °C)
6	NFM21HC221R1H3D	220 pF	±20 %	DC 50 V	700mA(DC)	0.3Ωmax.	1000MΩmin	Section 7.1 (-55 to 125 °C / -55 to 125 °C)
7	NFM21HC222R1H3D	2200 pF	±20 %	DC 50 V	1A(DC)	0.3Ωmax.	1000MΩmin	Section 7.1 (-55 to 125 °C / -55 to 125 °C)
8	NFM21HC223R1H3D	22000 pF	±20 %	DC 50 V	2A(DC)	0.03Ωmax.	1000MΩmin	Section 7.1 (-55 to 125 °C / -55 to 125 °C)
9	NFM21HC224R1A3D	0.22 uF	±20 %	DC 10 V	2A(DC)	0.03Ωmax.	1000MΩmin	Section 7.1 (-55 to 125 °C / -55 to 125 °C)
10	NFM21HC470U1H3D	47 pF	±20 %	DC 50 V	700mA(DC)	0.3Ωmax.	1000MΩmin	Section 7.1 (-55 to 125 °C / -55 to 125 °C)
11	NFM21HC471R1H3D	470 pF	±20 %	DC 50 V	1A(DC)	0.3Ωmax.	1000MΩmin	Section 7.1 (-55 to 125 °C / -55 to 125 °C)
12	NFM21HC474R1A3D	0.47 uF	±20 %	DC 10 V	2A(DC)	0.03Ωmax.	1000MΩmin	Section 7.1 (-55 to 125 °C / -55 to 125 °C)

6. Package

	MURATA PART NO.	(7) Packaging	Packaging Unit
1	NFM21HC101U1H3D	φ180mm Reel PAPER	4000 pcs./Reel
2	NFM21HC102R1H3D	φ180mm Reel PAPER	4000 pcs./Reel
3	NFM21HC104R1A3D	φ180mm Reel PAPER	4000 pcs./Reel
4	NFM21HC105R1C3D	φ180mm Reel PAPER	4000 pcs./Reel
5	NFM21HC220U1H3D	φ180mm Reel PAPER	4000 pcs./Reel
6	NFM21HC221R1H3D	φ180mm Reel PAPER	4000 pcs./Reel
7	NFM21HC222R1H3D	φ180mm Reel PAPER	4000 pcs./Reel
8	NFM21HC223R1H3D	φ180mm Reel PAPER	4000 pcs./Reel
9	NFM21HC224R1A3D	φ180mm Reel PAPER	4000 pcs./Reel
10	NFM21HC470U1H3D	φ180mm Reel PAPER	4000 pcs./Reel
11	NFM21HC471R1H3D	φ180mm Reel PAPER	4000 pcs./Reel
12	NFM21HC474R1A3D	φ180mm Reel PAPER	4000 pcs./Reel

Product specifications in this catalog are as of Dec.15,2014,and are subject to change or obsolescence without notice.
Please consult the approval sheet before ordering.
Please read rating and !Cautions first.

■AEC-Q200 Murata Standard Specification and Test Methods

Electrical Performance

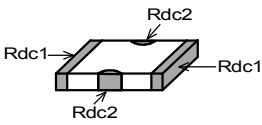
No	Item	Specification	Test Method
1	Capacitance (Cap.)	Meet item 5.	Frequency 22 to 100pF : 1±0.1MHz 220pF to 1uF : 1±0.1kHz Voltage : 1±0.2V(rms)
2	Insulation Resistance(I.R.)		Voltage : Rated Voltage Time : 2 minutes max.
3	DC Resistance (Rdc1,2)		Measured with 100mA max. Rdc1 : between signal terminals Rdc2 : between ground terminals 
4	Withstanding Voltage	Products shall not be damaged.	Test Voltage : Rated Voltage X 300% Time : 1 to 5 s Charge Current : 50 mA max.
5	Operating Temperature	Shown in item 5.	Includes self-heating
6	Storage Temperature		

Standard Testing Condition

< Unless otherwise specified >

Temperature : Ordinary Temp. / 15 °C to 35 °C

Humidity: Ordinary Humidity / 25 %(RH) to 85 %(RH)

< In case of doubt >

Temperature: 20 °C ± 2 °C

Humidity: 60 %(RH) to 70 %(RH)

Atmospheric pressure: 86 kPa to 106 kPa

7.

■ AEC-Q200 Murata Standard Specification and Test Methods

Mechanical Performance (based on Table 2 for Tantalum & Ceramic Capacitors)

AEC-Q200 Rev.C issued June 17, 2005

AEC-Q200			Murata Specification / Deviation
No.	Stress	Test Method	
3	High Temperature Exposure	Unpowered 1000 hours @ T=150C (Ceramics) Measurement at 24+/-2 hours after test conditon.	Meet Table D after testing.
4	Temperature Cycling	1000cycles (-55C to +125C) Measurement at 24+/-2 hours after test	Meet Table A after testing.
6	Moisture Resistance	t=24 hours/cycle. Note: Steps 7a & 7b not required. Unpowered.	Meet Table D after testing.
7	Biased Humidity	1000hours 85C/85%RH. Note: Ceramics only Specified conditions: Rated Voltage and 1.3 to 1.5 volts. Add 100Kohm resistor. Tantalums-Rated Voltage only. Measurement at 24+/-2 hours after test	Meet Table D after testing.
8	Operational Life	Condition D Steady State TA=125C Full rated ceramic caps Measurement at 24+/-2 hours after test conclusion.	Meet Table D after testing.
9	External Visual	Visual inspection	No abnormalities
10	Physical Dimension	Meet Item 4 (Type & Dimensions)	No defects
12	Resistance to Solvents	Per MIL-STD-202 Method 215	Not Applicable
13	Mechanical Shock	Figure 1 of Method 213. SMD:Condition F Leaded:Condition C	Meet Table C after testing.
14	Vibration	5g's for 20 minutes, 12cycles each of 3 orientations Use 8"X5" PCB, .031"thick. 7 secure points on one long side and 2 secure points at corners of opposite sides. Parts mounted within 2" from any secure point. Test from 10-2000Hz.	Meet Table C after testing.
15	Resistance to Soldering Heat	Note: Condition B No pre-heat of samples. Note:Single Wave Solder-Procedure 2 for SMD. Procedure 1 for Leaded with solder within 1.5mm of device body.	Meet Table A after testing. <u>Deviation for AEC-Q200:</u> Testing condition Flux: Ethanol solution of rosin, 25(wt)% Pre-heating: 150C+/-10C, 60 to 90s Solder: Sn-3.0Ag-0.5Cu Solder Temperature: 270C+/-5C Immersion Time: 10s+/-1s Immersion and emersion rates: 25mm/s Then measured after exposure in the room
16	Thermal Shock	-55C/+125C Note: Number of cycles required-300, Maximum transfer time-20 s, Dwell time-15 minuites. Air-Air.	Meet Table A after testing.
17	ESD	Per AEC-Q200-002	Component Classification:Meet Table E
18	Solderability	Per J-STD-002	95% of the terminations is to be soldered. Method B : Not Applicable
19	Electrical Characterization	Summary to show Min, Max, Mean and Standard deviation at room as well as Min and Max operating temperatures.	<u>Deviation for AEC-Q200:</u> Meet Item 5 (Rated value)

■ AEC-Q200 Murata Standard Specification and Test Methods

Mechanical Performance (based on Table 2 for Tantalum & Ceramic Capacitors)

AEC-Q200 Rev.C issued June 17, 2005

AEC-Q200			Murata Specification / Deviation
No.	Stress	Test Method	
21	Board Flex	Appendix 2. Note:2mm(min) for all except 3mm for class 1.	<p>Meet Table B after testing. Deviation for AEC-Q200: It shall be soldered on the Glass-epoxy substrate (t = 1mm). • Deflection : 2mm • Keeping Time : 30s</p>
22	Terminal Strength	Per AEC-Q200-006 A force of 1.8 kg for 60 s	<p>The electrode should show no failure after testing. Deviation for AEC-Q200: It shall be soldered on the substrate. • Applying Force : 17.6N • Applying Time : 60s</p>
23	Beam Load Test	Per AEC-Q200-003	<p>The chip endure 20N. Deviation for AEC-Q200 Place the capacitor in the beam load fixture as below figure. Pressure Jig: R0.5</p> <p>Speed supplied the Stress Load: 0.5mm/s.</p>

7.

■ AEC-Q200 Murata Standard Specification and Test Methods

Mechanical Performance (based on Table 2 for Tantalum & Ceramic Capacitors)

AEC-Q200 Rev.C issued June 17, 2005

Table A

Appearance	No damage
Capacitance Change	Within +/-7.5% at 20C
I.R.	1000M Ω min. (22pF-470000pF) 500M Ω min. (1000000pF)
DC Resistance(Rdc1,2)	0.5 Ω max (22pF-2200pF) 0.05 Ω max (22000pF-1000000pF)

Table B

Appearance	No damage
Capacitance Change	Within +/-12.5% at 20C
DC Resistance(Rdc1,2)	0.5 Ω max (22pF-2200pF) 0.05 Ω max (22000pF-1000000pF)

Table C

Appearance	No damage
Capacitance	Meet initial value (See Item 5 (Rated value))
DC Resistance(Rdc1,2)	0.5 Ω max (22pF-2200pF) 0.05 Ω max (22000pF-1000000pF)

Table D

Appearance	No damage
Capacitance Change	Within +/-12.5% at 20C
I.R.	1000M Ω min. (22pF-470000pF) 500M Ω min. (1000000pF)
DC Resistance(Rdc1,2)	0.5 Ω max (22pF-2200pF) 0.05 Ω max (22000pF-1000000pF)

Table E

Murata PN	DC Resistance (Rdc 1,2) Value After Testing (ohm) max.	ESD Component Classification
		1C: 1kV(DC) to <2kV(DC)
NFM21HC220U1H3D	0.5	1C
NFM21HC470U1H3D	0.5	1C
NFM21HC101U1H3D	0.5	1C
NFM21HC221R1H3D	0.5	1C
NFM21HC471R1H3D	0.5	1C
NFM21HC102R1H3D	0.5	1C
NFM21HC222R1H3D	0.5	1C
NFM21HC223R1H3D	0.05	1C
NFM21HC104R1A3D	0.05	1C
NFM21HC224R1A3D	0.05	1C
NFM21HC474R1A3D	0.05	1C
NFM21HC105R1C3D	0.05	1C

1. Operating Environment

Do not use this product under the following environmental conditions, on deterioration of the performance, such as insulation resistance may result from the use.

- (1) in the corrodible atmosphere (acidic gases, alkaline gases, chlorine, sulfur gases, organic gases and etc.)
- (2) in the atmosphere where liquid such as organic solvent, may splash on the products.
- (3) in the atmosphere where dust rises.

2. Caution (Rating)

Do not use products beyond the Operating Temperature Range, Rated Voltage and Rated Current.

3. Attention regarding product's lay out

< Attention regarding the heat generated by other products >

Please provide special attention when mounting products in close proximity to other products that radiate heat.

4. Attention regarding chip mounting

An excessively low bottom dead point of the suction nozzle imposes great force on the chip during mounting, causing cracked chips.

Please set the suction nozzle's bottom dead point on the upper surface of the board, after the board is adjusted flat. The chip received force (static loading) from the suction nozzle's should be 1N to 3N.

5. Note for Assembling

< Thermal Shock >

Pre-heating should be in such a way that the temperature difference between solder and products surface is limited to 100°C max. Also cooling into solvent after soldering should be in such a way that the temperature difference is limited to 100°C max.

9.

6. Attention Regarding P.C.B. Bending

The following shall be considered when designing P.C.B.'s and laying out products.

- (1) P.C.B. shall be designed so that products are not subject to the mechanical stress for board warpage.
[Products direction]

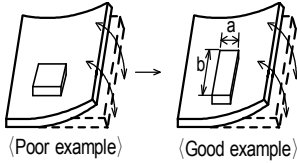

Products shall be located in the sideways direction (Length:a<b) to the mechanical stress.

- (2) Products location on P.C.B. near seam for separation.

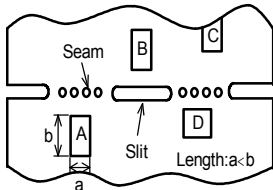

Products (A,B,C,D) shall be located carefully so that products are not subject to the mechanical stress due to warping the board. Because they may be subjected the mechanical stress in order of A > C > B ≧ D.

7. Pre-heating Temperature

Soldering shall be handled so that the difference between pre-heating temperature and solder temperature shall be limited to 100°C max. to avoid the heat stress for the products.

8. Reflow Soldering

- 1) Soldering paste printing for reflow

- Standard thickness of solder paste: 100µm to 150µm.
- Use the solder paste printing pattern of the right pattern.
- For the resist and copper foil pattern, use standard land dimensions.

- Standard printing pattern of solder paste.

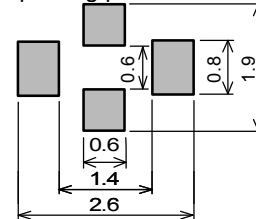

(in mm)

- 2) Soldering Conditions

Standard soldering profile and the limit soldering profile is as follows.

The excessive limit soldering conditions may cause leaching of the electrode and/or resulting in the deterioration of product quality.

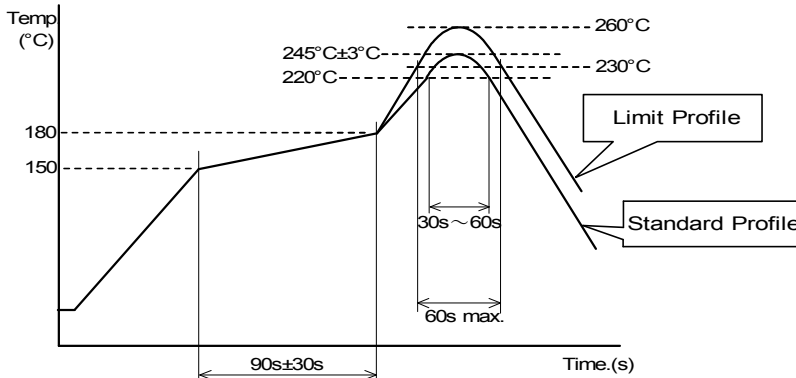

	Standard Profile	Limit Profile
Pre-heating	150°C ~ 180°C , 90s ± 30s	
Heating	above 220°C , 30s ~ 60s	above 230°C , 60s max.
Peak temperature	245°C ± 3°C	260°C , 10s
Cycle of reflow	2 times	2 times

9. Reworking with Soldering iron

The following conditions shall be strictly followed when using a soldering iron.

- Pre-heating : 150°C, 1 min
- Soldering iron output : 30W max.
- Tip temperature : 350°C max.
- Tip diameter : φ3mm max.
- Soldering time : 3(+1,-0) s
- Times : 2times max.

Note: Do not directly touch the products with the tip of the soldering iron in order to prevent the crack on the ceramic material due to the thermal shock.

10. Solder Volume

Solder shall be used not to be exceeded as shown below.

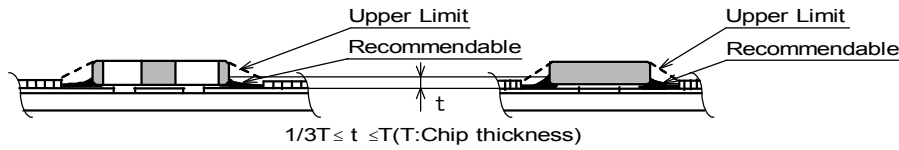

Accordingly increasing the solder volume, the mechanical stress to product is also increased. Excessive solder volume may cause the failure of mechanical or electrical performance.

11. Resin coating

The capacitance value may change and/or it may affect on the product's performance due to high cure-stress of resin to be used for coating / molding products. So please pay your careful attention when you select resin. In prior to use, please make the reliability evaluation with the product mounted in your application set.

12. Handling of a substrate

After mounting products on a substrate, do not apply any stress to the product caused by bending or twisting to the substrate when cropping the substrate, inserting and removing a connector from the substrate or tightening screw to the substrate. Excessive mechanical stress may cause cracking in the product.

Bending

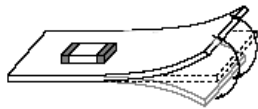

Twisting

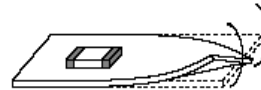

Failure to follow the above cautions may result, worst case, in a short circuit and cause fuming or partial dispersion when the product is used.

13. Fail-safe

Be sure to provide an appropriate fail-safe function on your product to prevent a second damage that may be caused by the abnormal function or the failure of our product.

14. Limitation of Applications

Please contact us before using our products for the applications listed below which require especially high reliability for the prevention of defects which might directly cause damage to the third party's life, body or property.

- (1) Aircraft equipment
- (2) Aerospace equipment
- (3) Undersea equipment
- (4) Power plant control equipment
- (5) Medical equipment
- (6) Transportation equipment (trains, ships, etc.)
- (7) Traffic signal equipment
- (8) Disaster prevention / crime prevention equipment
- (9) Data-processing equipment
- (10) Applications of similar complexity or with reliability requirements comparable to the applications listed in the above

Products can only be soldered with reflow.
 This product is designed for solder mounting.
 Please consult us in advance for applying other mounting method such as conductive adhesive.

1. Flux and Solder

Flux	Use rosin-based flux, Do not use highly acidic flux (with chlorine content exceeding 0.2(wt)%). Do not use water-soluble flux. Other flux (except above) Please contact us for details, then use.
Solder	Use Sn-3.0Ag-0.5Cu solder Use of Sn-Zn based solder will deteriorate performance of products. In case of using Sn-Zn based solder, please contact Murata in advance.

2. Cleaning Conditions

Products shall be cleaned on the following conditions.

- (1) Cleaning temperature shall be limited to 60°C max. (40°C max. for Isopropyl alcohol (IPA))
- (2) Ultrasonic cleaning shall comply with the following conditions, with avoiding the resonance phenomenon at the mounted products and P.C.B.

Power : 20W / l max.
 Frequency : 28kHz to 40kHz
 Time : 5 minutes max.

(3) Cleaner

- 1. Cleaner
Isopropyl alcohol (IPA)
- 2. Aqueous agent
PINE ALPHA ST-100S

(4) There shall be no residual flux and residual cleaner after cleaning.

In the case of using aqueous agent, products shall be dried completely after rinse with de-ionized water in order to remove the cleaner.

(5) Other cleaning
 Please contact us.

3. Standard Land Dimensions

The chip EMI filter suppresses noise by conducting the high-frequency noise element to ground.
 Therefore, to get enough noise reduction, feed through holes which is connected to ground-plane should be arranged according to the figure to reinforce the ground-pattern.

< Standard land dimensions for reflow >

·Side on which chips are mounted

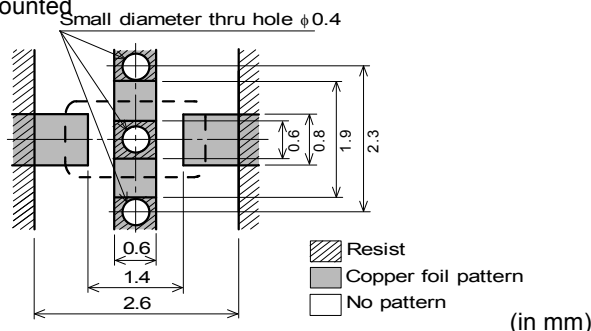

4. Storage and Delivery condition

(1) Storage period

Use the products within 12 months after delivered.
 Solderability should be checked if this period is exceeded.

(2) Storage environment condition

- Products should be stored in the warehouse on the following conditions.
 - Temperature: -10 to +40°C
 - Humidity: 15 to 85% relative humidity
 - No rapid change on temperature and humidity
- Don't keep products in corrosive gases such as sulfur, chlorine gas or acid, or it may cause oxidization of electrode, resulting in poor solderability.
- Products should be stored on the palette for the prevention of the influence from humidity, dust and so on.
- Products should be stored in the warehouse without heat shock, vibration, direct sunlight and so on.
- Products should be stored under the airtight packaged condition.

(3) Delivery

Care should be taken when transporting or handling product to avoid excessive vibration or mechanical shock.

- (1) Please make sure that your product has been evaluated in view of your specifications with our product being mounted to your product.
- (2) You are requested not to use our product deviating from the agreed specifications.
- (3) We consider it not appropriate to include any terms and conditions with regard to the business transaction in the product specifications, drawings or other technical documents. Therefore, if your technical documents as above include such terms and conditions such as warranty clause, product liability clause, or intellectual property infringement liability clause, they will be deemed to be invalid.

Mouser Electronics

Authorized Distributor

Click to View Pricing, Inventory, Delivery & Lifecycle Information:

Murata:

[NFM21HC223R1H3D](#) [NFM21HC101U1H3D](#) [NFM21HC222R1H3D](#) [NFM21HC102R1H3D](#) [NFM21HC221R1H3D](#)
[NFM21HC471R1H3D](#) [NFM21HC220U1H3D](#) [NFM21HC470U1H3D](#) [NFM21HC104R1A3D](#) [NFM21HC224R1A3D](#)
[NFM21HC474R1A3D](#) [NFM21HC105R1C3D](#)