

REVISIONS					
P	LTR	DESCRIPTION	DATE	DWN	APVD
	V	REVISED PER ECO-14-015277	12FEB2015	NK	DR
	V1	REVISED PER ECO-17-007400	15DEC2017	RS	DR

AMP WIRE RANGE	E13288 Listed	LR7189 Certified
22-16 AWG SOLID OR STRANDED	22-16 AWG SOLID OR STRANDED	22-16 AWG SOLID OR STRANDED

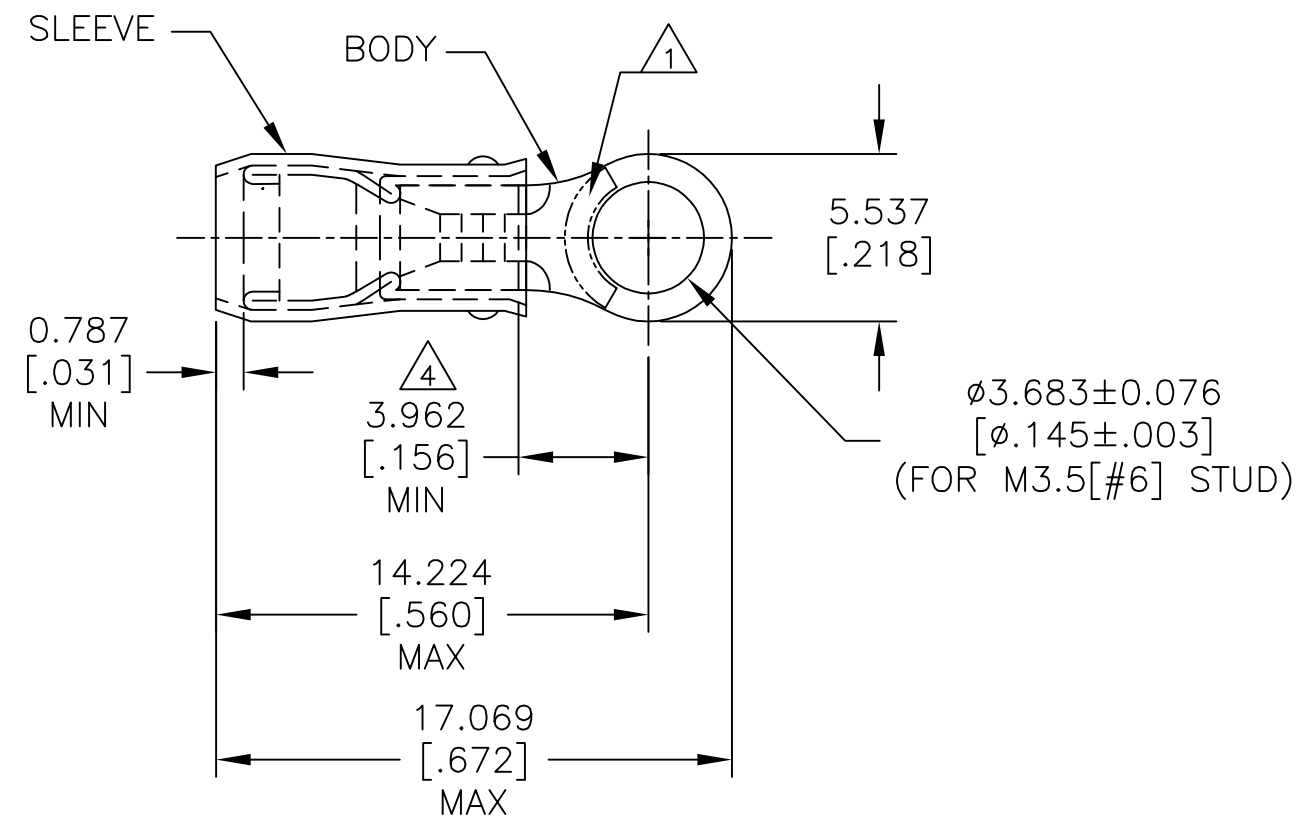

- 1 STAMP AMP 22-18* APPROX AS SHOWN
22-16 TERMINALS ARE STAMPED 22-18 IN
ACCORDANCE WITH MILITARY SPEC SAE AS7928
COMMERCIAL WIRE RANGE IS 22-16.
- 2 WIRE INSULATION : $\phi 2.032-3.175[\phi .080-.125]$
- 3 BODY MATERIAL THK: $0.787 \pm 0.051[.031 \pm .002]$
- 4 APPLIES FROM EDGE OF METAL WIRE BARREL
TO CENTER OF STUD HOLE.

-	100	LOOSE PIECE, BOX	8-36149-1
MS25036-101 CLASS 2	5000	ON TAPE, REEL	2-36149-2
MS25036-101 CLASS 1 & 2	1000	LOOSE PIECE	36149
MILITARY P/N AND CLASS	QUANTITY	PACKAGE TYPE	PART NO

AMP INCORPORATED CUSTOMER SERVICE SYSTEMS		MAX RECOMMENDED OPERATING TEMPERATURE: 105°C[221°F] MAX	THIS DRAWING IS A CONTROLLED DOCUMENT.		DWN DK SCHRUM 9/8/93	TE Connectivity					
FOR ADDITIONAL PRODUCT INFORMATION OR COPIES OF DRAWINGS AND TECHNICAL DOCUMENTS	PRODUCT INFORMATION CENTER 1-800-522-6752	VOLTAGE RATING: 300 V MAX	DIMENSIONS: mm[INCHES]	TOLERANCES UNLESS OTHERWISE SPECIFIED:	CHK RE HERSEY 9/8/93					NAME TERMINAL, RING TONGUE, PIDG™, WIRE SIZE, 22-16 AWG	
FOR APPLICATION TOOLING INFORMATION	TOOLING ASSISTANCE CENTER 1-800-722-1111	CIRCULAR MIL AREA: 0.26-1.65mm²[509-3,260] CIR MILS SOLID OR STRANDED		0 PLC ± - 1 PLC ± - 2 PLC ± - 3 PLC ± 0.127[.005] 4 PLC ± - ANGLES ± -	APVD ML ELLIS 9/8/93	PRODUCT SPEC UL 486 A-B		SIZE	CAGE CODE	DRAWING NO	RESTRICTED TO
FOR ORDER ENTRY	1-800-526-5142		MATERIAL COPPER PER ASTM B-152 SLEEVE, RED NYLON	FINISH TIN PLATE PER ASTM B545	APPLICATION SPEC 114-2157	WEIGHT -		A3	00779	C-36149	-
CUSTOMER DRAWING								SCALE NTS	SHEET 1 OF 2	REV V1	

P	LTR	DESCRIPTION	DATE	DWN	APVD
-	-	SEE SHEET 1	-	-	-

AMP

WIRE RANGE

SEE TABLE

STRANDED

3 STRIPES EQUALLY SPACED FOR COLOR CODE: SEE TABLE

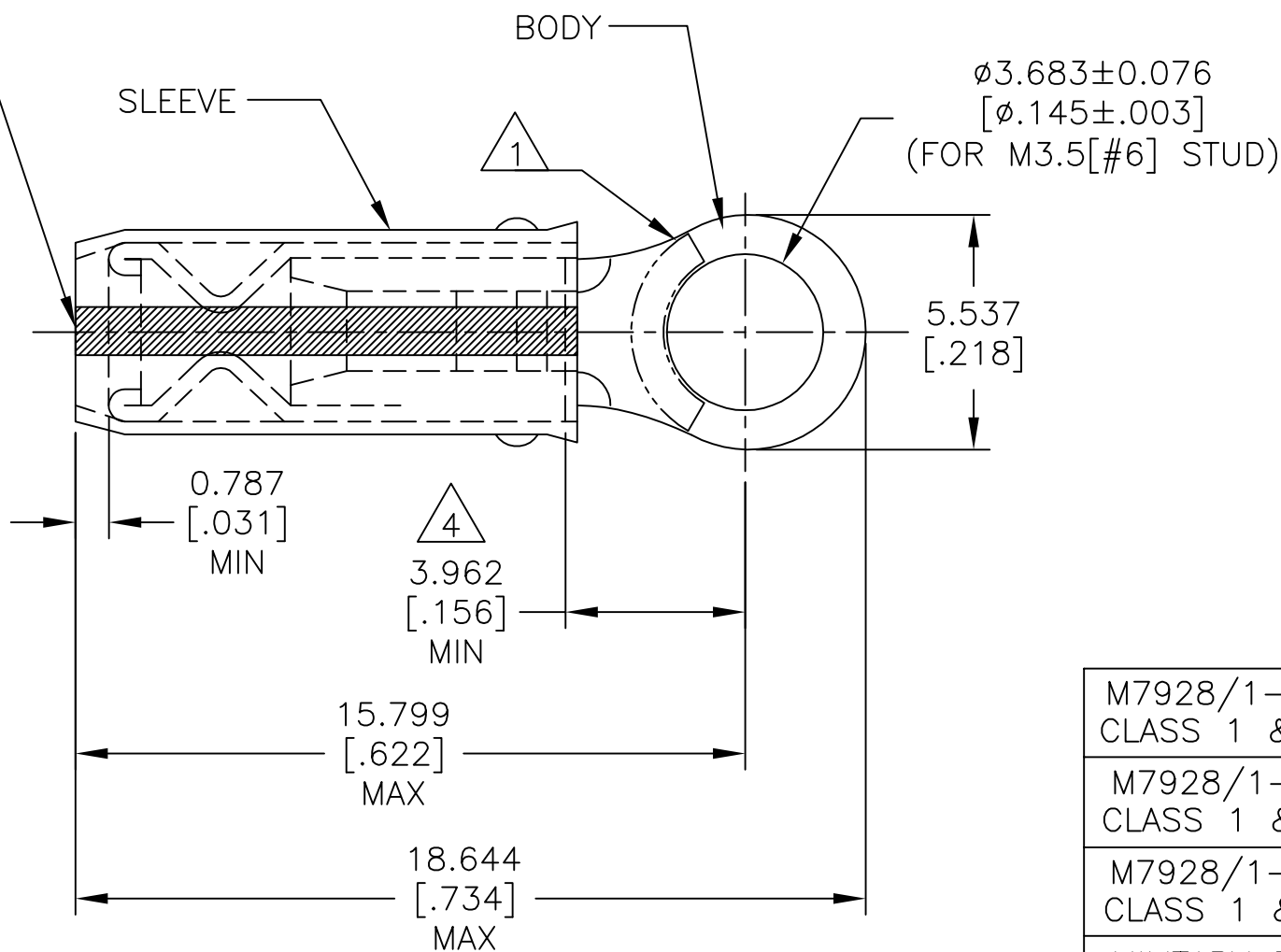

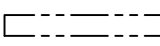
1 STAMP AMP  APPROX AS SHOWN SEE TABLE BELOW.

2 WIRE INSULATION : $\phi 0.965-2.794[\phi 0.038-.110]$ FOR 22 AWG
 $\phi 1.168-2.794[\phi 0.046-.110]$ FOR 20 AWG
 $\phi 1.422-2.794[\phi 0.056-.110]$ FOR 18 AWG.

3 BODY MATERIAL THK: $0.787\pm 0.051[.031\pm .002]$

4 APPLIES FROM EDGE OF METAL WIRE BARREL TO CENTER OF STUD HOLE.

M7928/1-30 CLASS 1 & 2	WHITE	18*	18	1000	LOOSE PIECE	2-36149-5
M7928/1-21 CLASS 1 & 2	RED	20*	20	1000	LOOSE PIECE	2-36149-4
M7928/1-12 CLASS 1 & 2	GREEN	22*	22	1000	LOOSE PIECE	2-36149-3
MILITARY P/N AND CLASS	STRIPE COLOR	STAMPING	WIRE SIZE	QUANTITY	PACKAGE TYPE	PART NO

AMP INCORPORATED
CUSTOMER SERVICE SYSTEMS

MAX RECOMMENDED OPERATING TEMPERATURE:
105°C[221°F] MAX

THIS DRAWING IS A CONTROLLED DOCUMENT.

DWN DK SCHRUM 9/8/93

CHK RE HERSEY 9/8/93

APVD ML ELLIS 9/8/93

PRODUCT SPEC

APPLICATION SPEC

NOT AVAILABLE

WEIGHT -

CUSTOMER DRAWING

STE TE Connectivity

NAME
TERMINAL, RING TONGUE, I.R., PIDG™
WIRE SIZE, 22-16 AWG

SIZE A3 CAGE CODE 00779 DRAWING NO C-36149 RESTRICTED TO -

FOR ADDITIONAL PRODUCT INFORMATION OR COPIES OF DRAWINGS AND TECHNICAL DOCUMENTS

PRODUCT INFORMATION CENTER
1-800-522-6752

FOR APPLICATION TOOLING INFORMATION

TOOLING ASSISTANCE CENTER
1-800-722-1111

FOR ORDER ENTRY

1-800-526-5142

VOLTAGE RATING: 300 V MAX

WIRE RANGE: CIRC MIL AREA:
22 0.38mm² [754]
20 0.60mm² [1,186]
18 0.96mm² [1,900]
STRANDED

DIMENSIONS:
mm[INCHES]

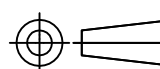

TOLERANCES UNLESS OTHERWISE SPECIFIED:
0 PLC ± -
1 PLC ± -
2 PLC ± -
3 PLC ± 0.127[.005]
4 PLC ± -
ANGLES ± -

MATERIAL
COPPER PER ASTM B-152 SLEEVE, RED NYLON

FINISH
TIN PLATE PER ASTM B545

SCALE NTS SHEET 2 OF 2 REV V1