

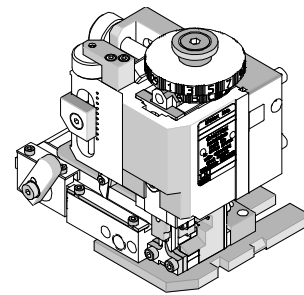

**FineAdjust Applicator
Specification Sheet
Part No. 63900-7800**



FEATURES

- Quick punch removal with the push of a button for fast and easy tooling change
- Applicator designed to industry standard mounting and shut height 135.80mm (5.346")
- Quick set-up time; plus the crimp height, track and feed adjustments can be set without removing the applicator from the press
- Fine adjustment allows users to achieve target with little effort by adjusting in increments of .015mm (.0006") for conductor crimp height and .063mm (.0025") for insulation height
- Independent adjustment rings allow users to quickly adjust the conductor or insulation crimp height without affecting each other
- Directly adapts to most automatic wire processing machines

SCOPE

Products: .250 Heavy Tab (Series 35452 Type A) Terminals, 12-14 AWG.

Terminal Series No.	Terminal Order No.	Wire Size		Insulation Diameter				Strip Length	
				IPC/WHMA-A620 ♦		Terminal ♦♦			
		AWG	mm ²	mm	In.	mm	In.	mm	In.
35452	35452-9902	12-14	3.3-2.08	3.50-4.20	0.138-0.165	3.00-4.20	.118-.165	4.80-5.20	.189-.205
35453	35453-9902	12-14	3.3-2.08	3.50-4.20	0.138-0.165	3.00-4.20	.118-.165	4.80-5.20	.189-.205

♦ To achieve optimum IPC-A620 insulation crimps, use this insulation OD range.
♦♦ Overall insulation OD specification for terminal.

DEFINITION OF TERMS

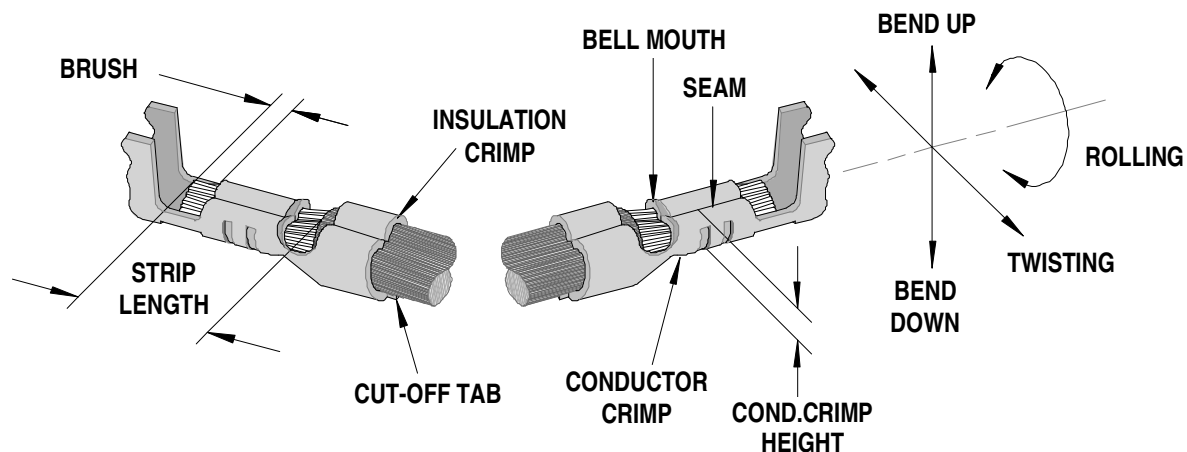

The above terminal drawing is a generic terminal representation. It is not an image of a terminal listed in the scope.

CRIMP SPECIFICATION

Terminal Series No.	Bell mouth		Cut-off Tab Maximum		Conductor Brush	
	mm	In.	mm	In.	mm	In.
35452	0.3-0.6	.012-.024	0.30	.012	0.0-1.0	0-.039

Terminal Series No.	Bend up	Bend down	Twist	Roll	Punch Width mm (Ref)				Seam Seam shall not be open and no wire allowed out of the crimping area
	Degree		Degree		Conductor		Insulation		
	mm	In	mm	In	mm	In	mm	In	
35452	5	5	5	5	3.9	0.153	5.6	0.22	

After crimping, the conductor profile should measure the following.

Terminal Series No.	Wire Size		Conductor Crimp				Insulation Crimp Maximum				Pull Force Minimum	
			Height		Width (Ref)		Height		Width (Ref)			
	AWG	mm ²	mm	In.	mm	In.	mm	In.	mm	In.	Kgf	Lb.
35452	12	3.3	2.05-2.25	.080-.089	3.80-4.00	0.150-0.157	--	--	5.6	0.22	35.0	77.2
	14	2.08	1.75-1.95	.069-.077	3.80-4.00	0.150-0.157	--	--	5.6	0.22	30.0	66.1

Pull Force should be measured with no influence from the insulation crimp.

The above specifications are guidelines to an optimum crimp.

PARTS LIST

FineAdjust Applicator 63900-7800				
Item	Order No	Engineering No.	Description	Quantity
Perishable Tooling				
	63900-7870	63900-7870	Tool Kit (All "Y" Items)	REF
1	63444-3913	63444-3913	Conductor Punch	1 Y
2	63445-3962	63445-3962	Conductor Anvil	1 Y
3	63446-5617	63446-5617	Insulation Punch	1 Y
4	63445-5613	63445-5613	Insulation Anvil	1 Y
5	63443-0035	63443-0035	Front Cut-Off Plunger	1 Y
6	63443-0036	63443-0036	Front Plunger Retainer	1 Y
Other Components (REF 007850)				
7	11-18-4083	60707-8	Feed Guide	1
8	63700-0539	63700-0539	Cut-Off Plunger Spring	1
9	63443-3160	63443-3160	Plunger Striker	1
10	63443-0009	63443-0009	Front Scrap Chute	1
11	63443-0025	63443-0025	Key	1
12	63443-0090	63443-0090	Wire Stop	1
13	63443-1718	63443-1718	18.80mm Height Spacer	1
14	63443-2201	63443-2201	1.00mm Coarse Spacer	1
15	63443-2213	63443-2213	13.00mm Coarse Spacer	1
16	63443-2309	63443-2309	3.45mm Fine Spacer	1
17	63443-6119	63443-6119	Rear Cover	1
Frame				
18	63800-4901	63800-4901	Top	1
19	63801-3281	63801-3281	Base	1
20	63801-4650	63801-4650	Track	1
Hardware				
21	N/A	N/A	M3 by 6 Long SHCS	2**
22	N/A	N/A	M3 by 6 Long FHCS	1**
23	N/A	N/A	M4 by 6 Long SHCS	2**
24	N/A	N/A	M4 by 12 Long BHCS	2**
25	N/A	N/A	M4 by 50 Long SHCS	2**
26	N/A	N/A	M5 by 12 Long SHCS	1**
27	N/A	N/A	#10-32 by 3/8" Long Flat Point SSS	1**
28	N/A	N/A	#10-32 Hex Jam Nut	1**
** Available from an industrial supply company such as MSC (1-800-645-7270).				

Assembly Drawing

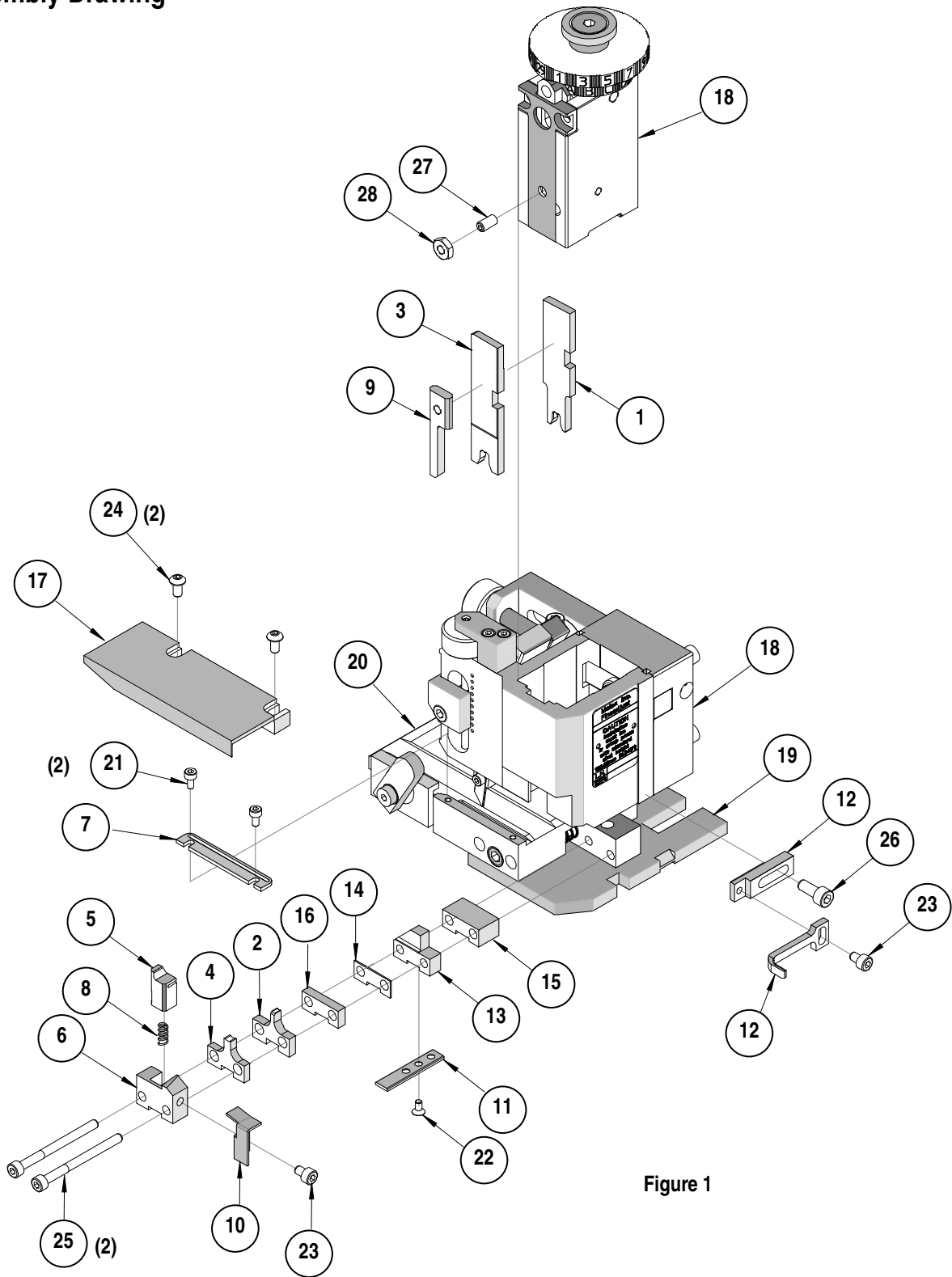

Figure 1

NOTES

1. Molex recommends an extra perishable tooling kit be maintained at your facility.
2. Verify tooling alignment by manually cycling the press and Applicator before crimping under power. Check that all screws are tight.
3. Slugs, Terminals, Dirt and Oil should be kept clear of work area.
4. Wear safety glasses at all times.
5. For recommended maintenance refer to the FineAdjust Manual.

CAUTION: This applicator should only be used in a press with a shut height of 135.80 mm (5.346"). Tooling damage could result at a lower setting.

CAUTION: To prevent injury never operate this Applicator without the guards supplied with the press or wire-processing machine in place. Reference the press or wire processing manufacturer's instruction manual.

CAUTION: Molex crimp specifications are valid only when used with Molex terminals, applicators and tooling.

Americas Headquarters
Lisle, Illinois 60532 U.S.A.
1-800-78MOLEX
amerinfo@molex.com

Far East North Headquarters
Yamato, Kanagawa, Japan
81-462-65-2324
feninfo@molex.com

Far East South Headquarters
Jurong, Singapore
65-6-268-6868
fesinfo@molex.com

European Headquarters
Munich, Germany
49-89-413092-0
eurinfo@molex.com

Corporate Headquarters
2222 Wellington Ct.
Lisle, IL 60532 U.S.A.
630-969-4550
Fax: 630-969-1352

Visit our Web site at <http://www.molex.com>

Mouser Electronics

Authorized Distributor

Click to View Pricing, Inventory, Delivery & Lifecycle Information:

[Molex:](#)

[63900-7870](#) [63443-2309](#)