

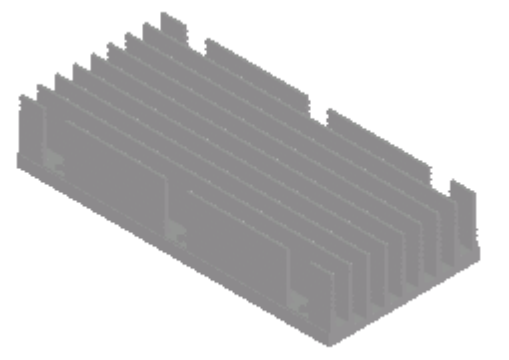

VICOR CONFIDENTIAL
 THIS DOCUMENT AND THE DATA DISCLOSED HEREIN OR
 HEREWITH IS NOT TO BE REPRODUCED, USED OR
 DISCLOSED IN WHOLE OR IN PART TO ANYONE WITHOUT
 THE PERMISSION OF VICOR CORP.

REV.	DESCRIPTION	DATE	APPROVED
3	RELEASED PER E090033	AR 01/09/09	REJH
4	REVISED PER E092035	JS 11/16/09	REJH
5	REDRAWN PER E100871	DCS 06/31/10	KUK
6	REVISED PER E111266	VSS 12/22/11	REJH
7	REVISED PER E120702	ZMB 07/31/12	REJH

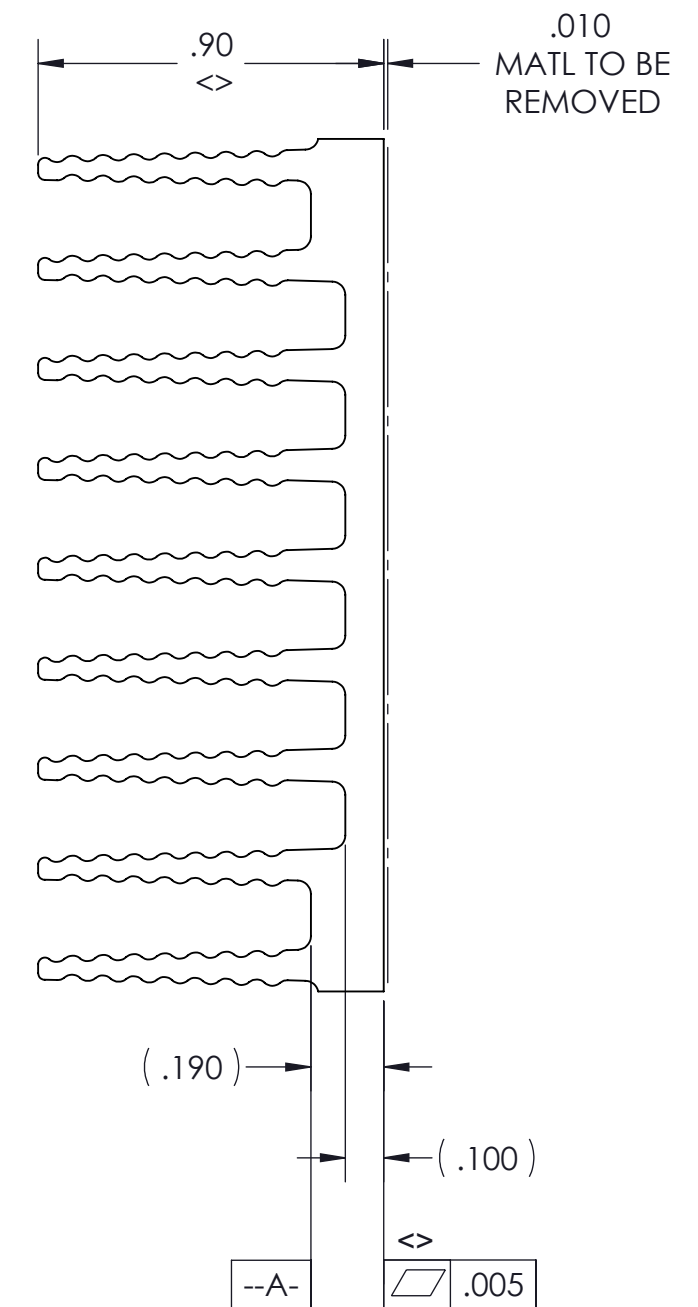
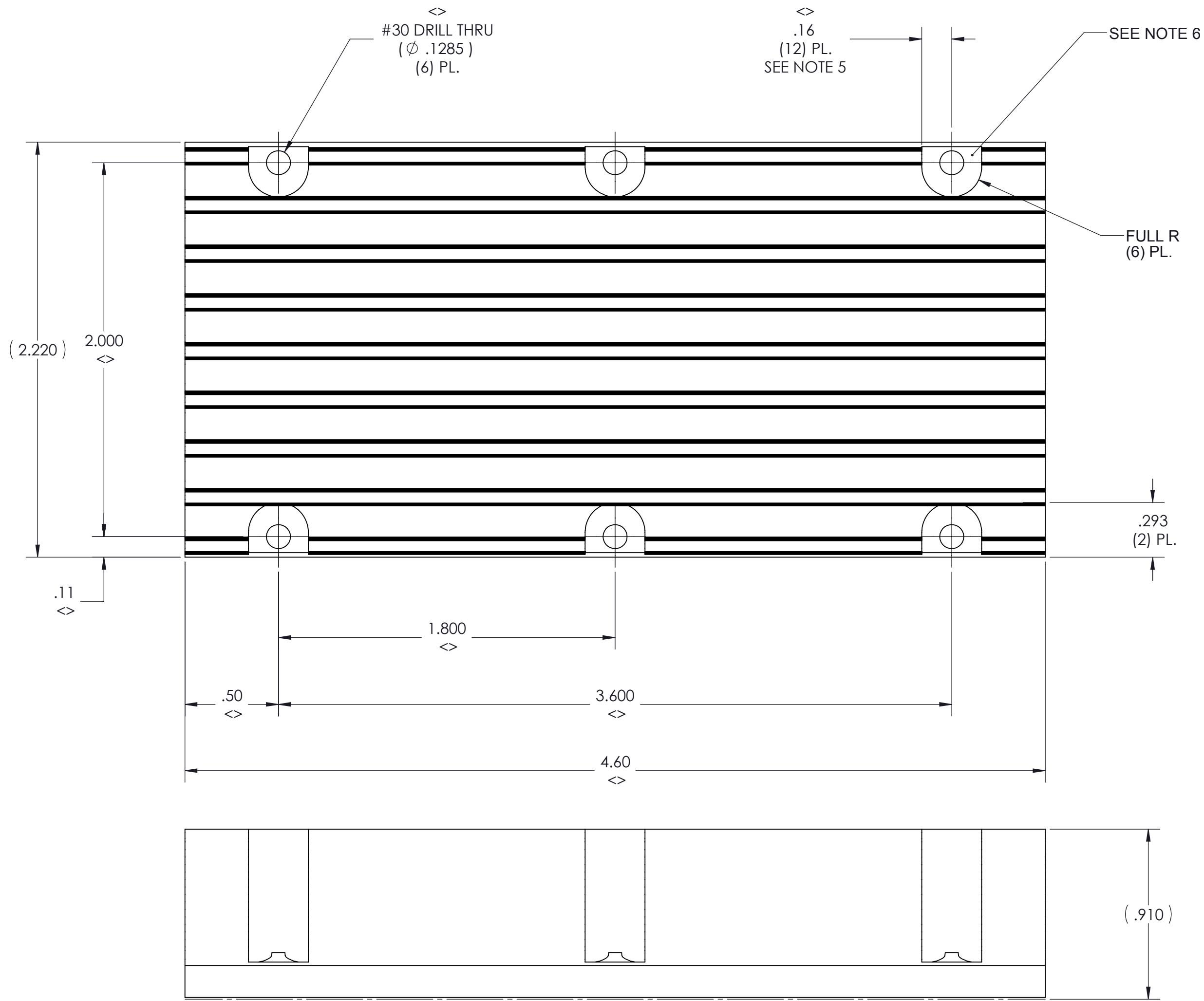

- NOTES:
1. MATERIAL: EXTRUSION SEE SHEET 2 OF 2
 2. REMOVE ALL BURRS AND SHARP EDGES.
 - <>3. CLEAR FINISH, RoHS COMPLAINT PER CST-0001, LATEST REVISION PER
 A)CHROMIUM FREE, OR
 B)TRIVALENT CHROMIUM IN ACCORDANCE WITH MIL-DTL-5541, TYPE II, CLASSS 1A OR 3.
 SEE CST-0003 FOR TYPES OF AVAILABLE FINISHES.
 4. "<>" DENOTES CRITICAL CHARACTERISTIC FOR LOT INSPECTION.
 5. DIMENSIONS APPLIES AT SURFACE -A- (12) PL.
 6. MACHINED SURFACE TO BE .010 MAX BELOW SURFACE -A- (6) PL.
 7. DIMENSIONS ARE INCHES ONLY.

DRAWN BY David Schmidt	DATE 06/30/2010	VICOR SWD	
UNLESS OTHERWISE SPECIFIED DIMENSIONS ARE : INCH / (MM)		HS LF 22.86MM CFG "A"	
TOLERANCES ARE: DECIMALS ±.01 (0.25) X.XX (X.X) ±.01 (0.25) X.XXX (X.XX) ±.005 (0.127)		SIZE C	CAGE CODE 67131
THIRD ANGLE PROJECTION  DO NOT SCALE DRAWING		DWG NO 30181	REV 7
SCALE 1:1		SHEET 1 OF 2	

VICOR CONFIDENTIAL
 THIS DOCUMENT AND THE DATA DISCLOSED HEREIN OR
 HEREWITH IS NOT TO BE REPRODUCED, USED OR
 DISCLOSED IN WHOLE OR IN PART TO ANYONE WITHOUT
 THE PERMISSION OF VICOR CORP.

REV.	DESCRIPTION	DATE	APPROVED
	SEE SHEET 1 OF 2		

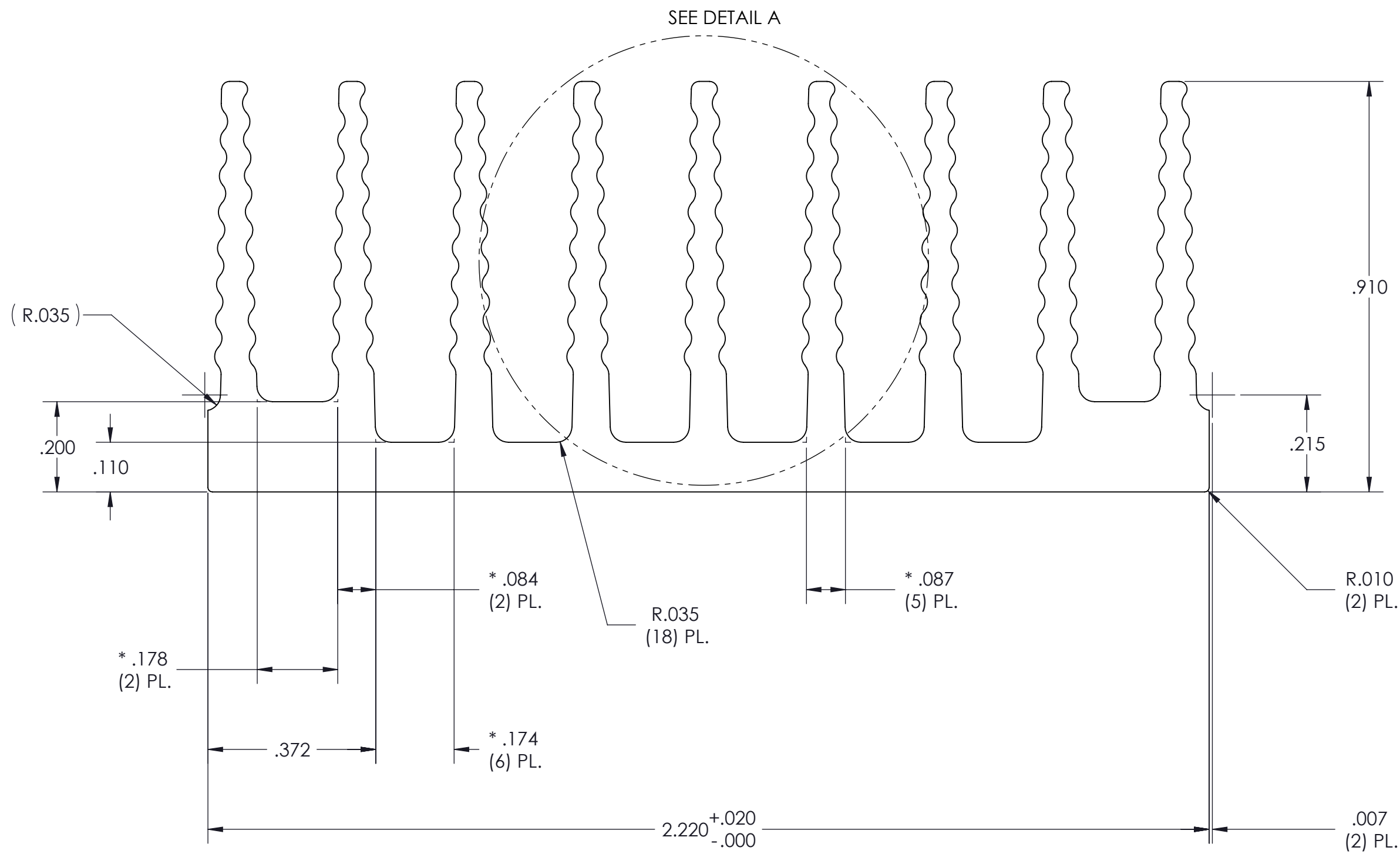

PROFILE COMMON FOR
30123
30181
30189
30182
30188

- NOTES:
1. MATERIAL: ALUMINUM 6063-T5
 2. * DENOTES DIMENSION TO THEORETICAL SHARP CORNER.
 3. ALL DIMENSIONS ARE CRITICAL CHARACTERISTICS.
 4. RoHS COMPLIANT PER CST-0001 LATEST REVISION.
 5. WORKMANSHIP STANDARDS WS-0004, WS-0006 AND WS0007 APPLY TO THIS PART.
 6. DIMENSIONS ARE INCHES ONLY.

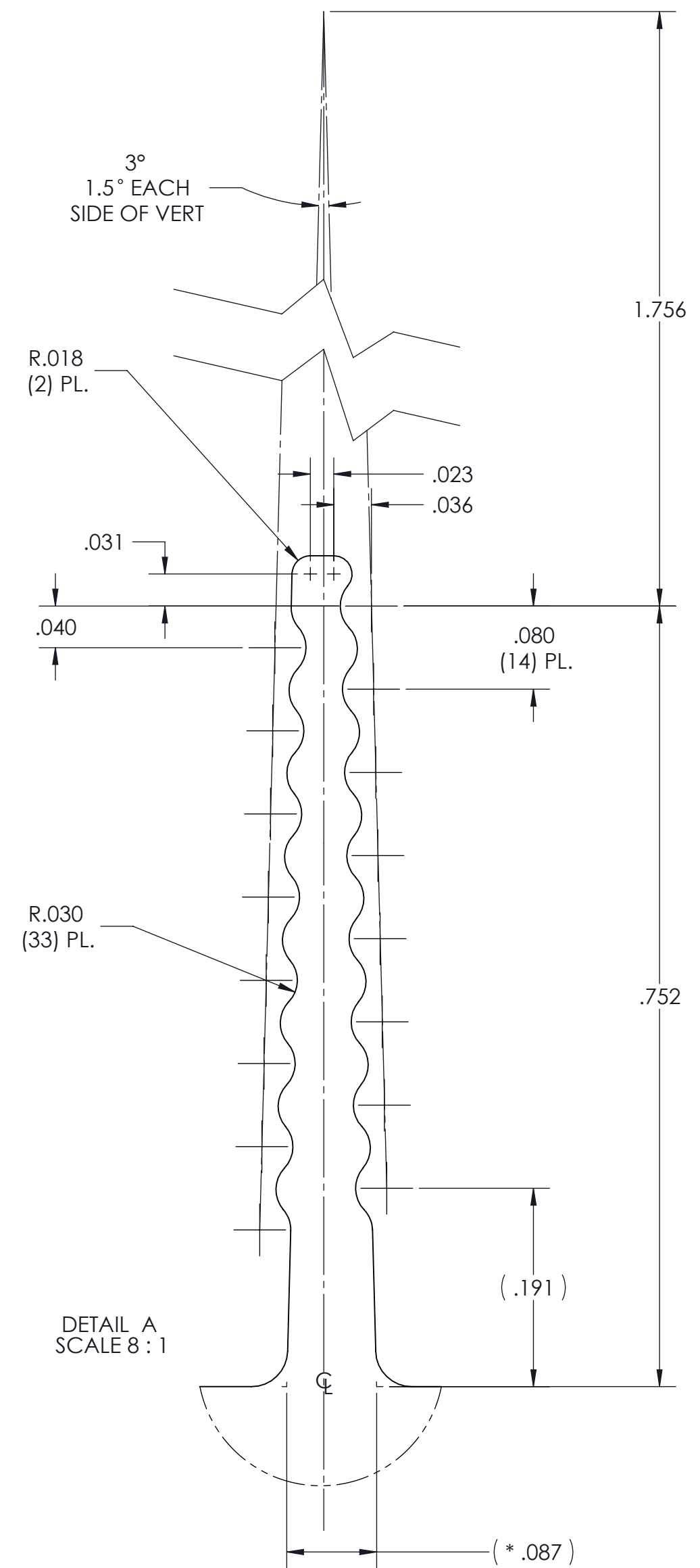

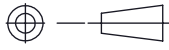
DRAWN BY David Schmidt	DATE 06/30/2010	VICOR SWD			
UNLESS OTHERWISE SPECIFIED DIMENSIONS ARE : INCH / (MM)		HS LF 22.86MM CFG "A" EXTRUSION			
TOLERANCES ARE: DECIMALS ANGLES X.XX [X.X] = ±0.01 [0.25] ±1° X.XXX [X.XX] = ±0.005 [0.127]		SIZE C	CAGE CODE 67131	DWG NO 30181	REV 7
THIRD ANGLE PROJECTION 		SCALE 1:1	SHEET 2 OF 2		

Mouser Electronics

Authorized Distributor

Click to View Pricing, Inventory, Delivery & Lifecycle Information:

[Vicor:](#)

[30181](#)