

SUGGESTED PRINTED CIRCUIT BOARD MOUNTING DIMENSIONS

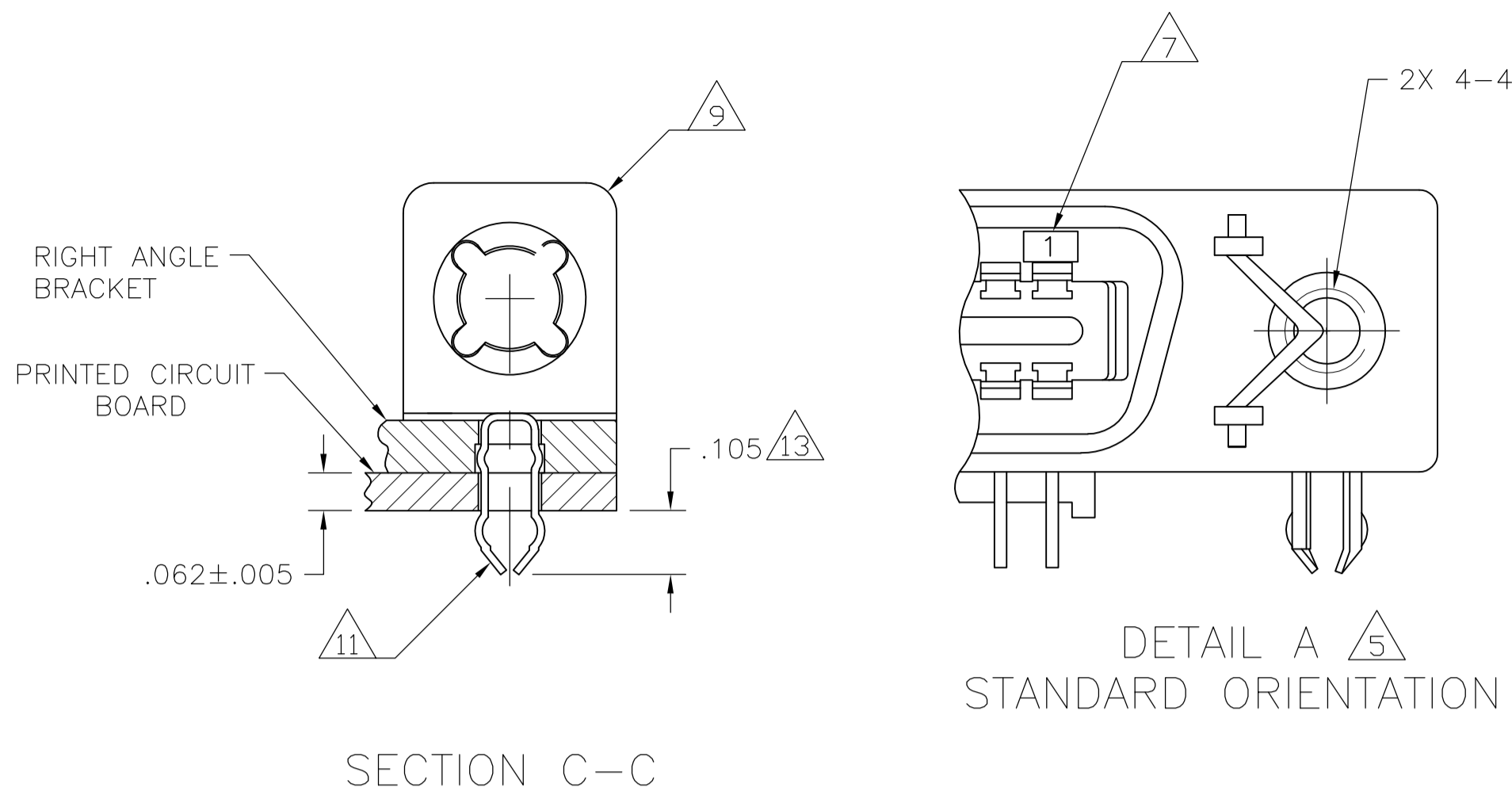

SECTION C-C

DETAIL A STANDARD ORIENTATION

- 1 MATERIAL: HOUSING, RIGHT ANGLE BRACKET, ADAPTER COMB & TERMINAL SUPPORT PLATE - THERMOPLASTIC, BLACK. RECEPTACLE SHIELD - BRIGHT NICKEL OVER COPPER PLATED DIE CASTING. TERMINALS - HIGH STRENGTH COPPER ALLOY PLATED WITH EITHER .000030 MIN GOLD PLATE OR GOLD FLASH OVER PALLADIUM NICKEL PLATE, .000030 MIN TOTAL ON MATING SURFACE, .000120 MIN TIN PLATE ON TAILS. ALL OVER .000050 MIN NICKEL UNDERPLATE OVER ENTIRE TERMINAL. GROUND BRACKET - TIN PLATED CARBON STEEL. BAIL CLIPS - PASSIVATED STAINLESS STEEL.
- 2 THE CONTACT SURFACES OF THE TERMINALS ARE COATED WITH LUBRICANT.
- 3 CENTER TO CENTER SPACING OF TERMINALS IS .085 NOMINAL.
- 4 ALL DIMENSIONS ARE MAXIMUM UNLESS OTHERWISE SPECIFIED.
- 5 DETAIL "A" IS VIEWED FROM MATING SIDE OF THE RECEPTACLE ASSEMBLY.
- 6 SHIELD IS ASSEMBLED TO RECEPTACLE ASSEMBLY BEFORE SHIPMENT.
- 7 TERMINAL 1 IS LOCATED IN THIS ROW FOR STANDARD ORIENTATION, SEE DETAIL A.
- 8 PANEL THICKNESS RANGE: .062 MAXIMUM.
- 9 GROUNDING BRACKET RETAINS CONNECTOR IN .062 THICK PC BOARD WITHOUT ADDITIONAL HARDWARE.
- 10 IF TERMINALS DO NOT EXTEND BELOW COMB, THEN COMB SHALL BE PARTIALLY RETRACTED, BEFORE INSERTING CONNECTOR INTO THE PC BOARD.
- 11 GROUNDING BRACKET LOCATES CONNECTOR FLUSH WITH TOP OF PC BOARD AND SPRING LOCKS BENEATH.
- 12 CYLINDRICAL SHAPE OFFERS 180° OF SOLDERING SURFACE.
- 13 SURFACE AREA OF GROUNDING BRACKET BELOW PC BOARD SHALL PASS SOLDERABILITY REQUIREMENTS IN ACCORDANCE WITH AMP SPECIFICATION 109-11-2, DISCOLORATION, SCRATHES, SPOTS AND OTHER COSMETIC DEFICIENCIES TYPICAL OF BARREL PLATING PROCESS ARE ACCEPTABLE PROVIDING PARTS PASS 24 HOUR EXPOSURE AT 95% RH AT 40°C, WITHOUT EVIDENCE OF CORROSION.

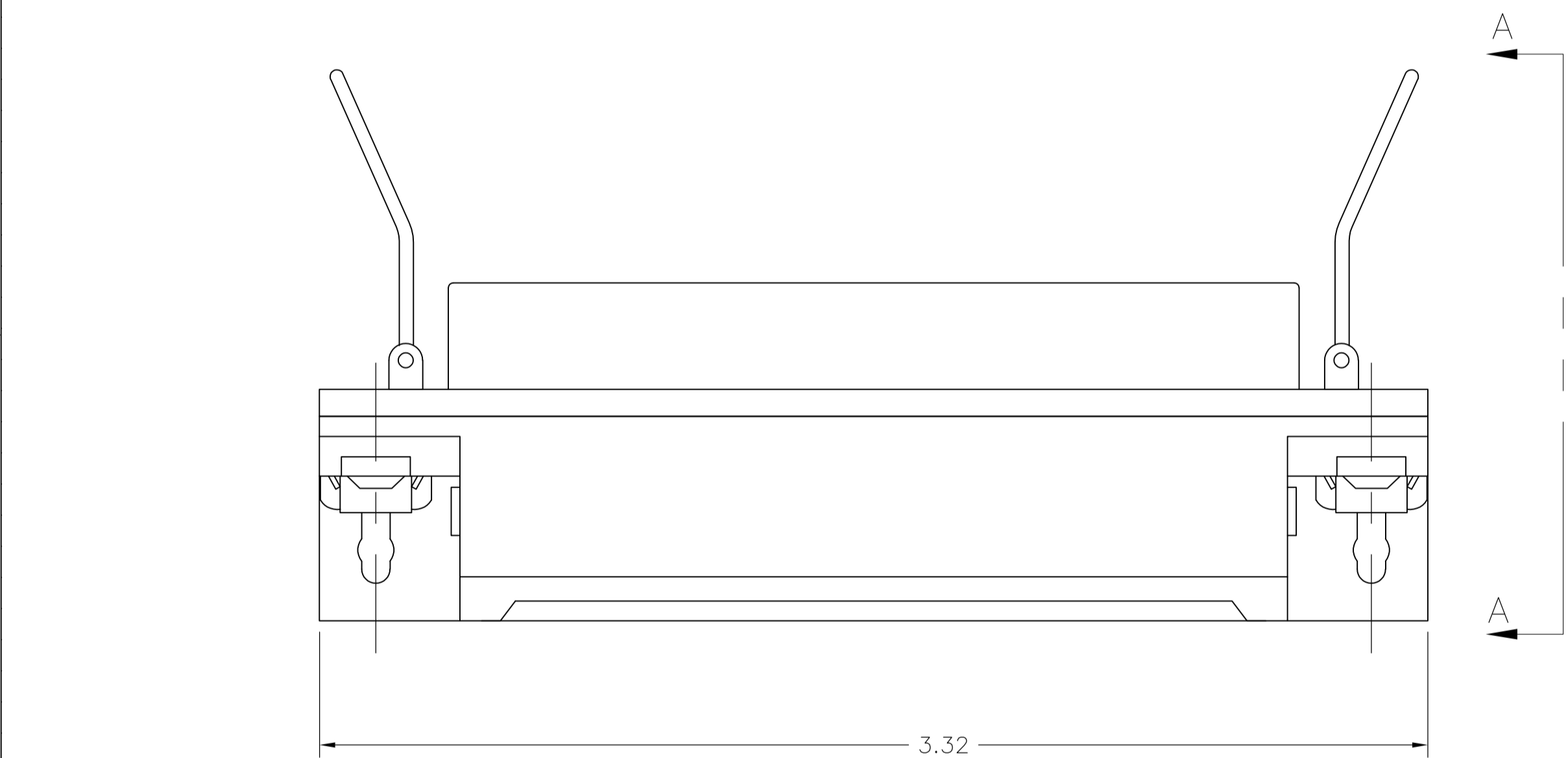

TOP VIEW

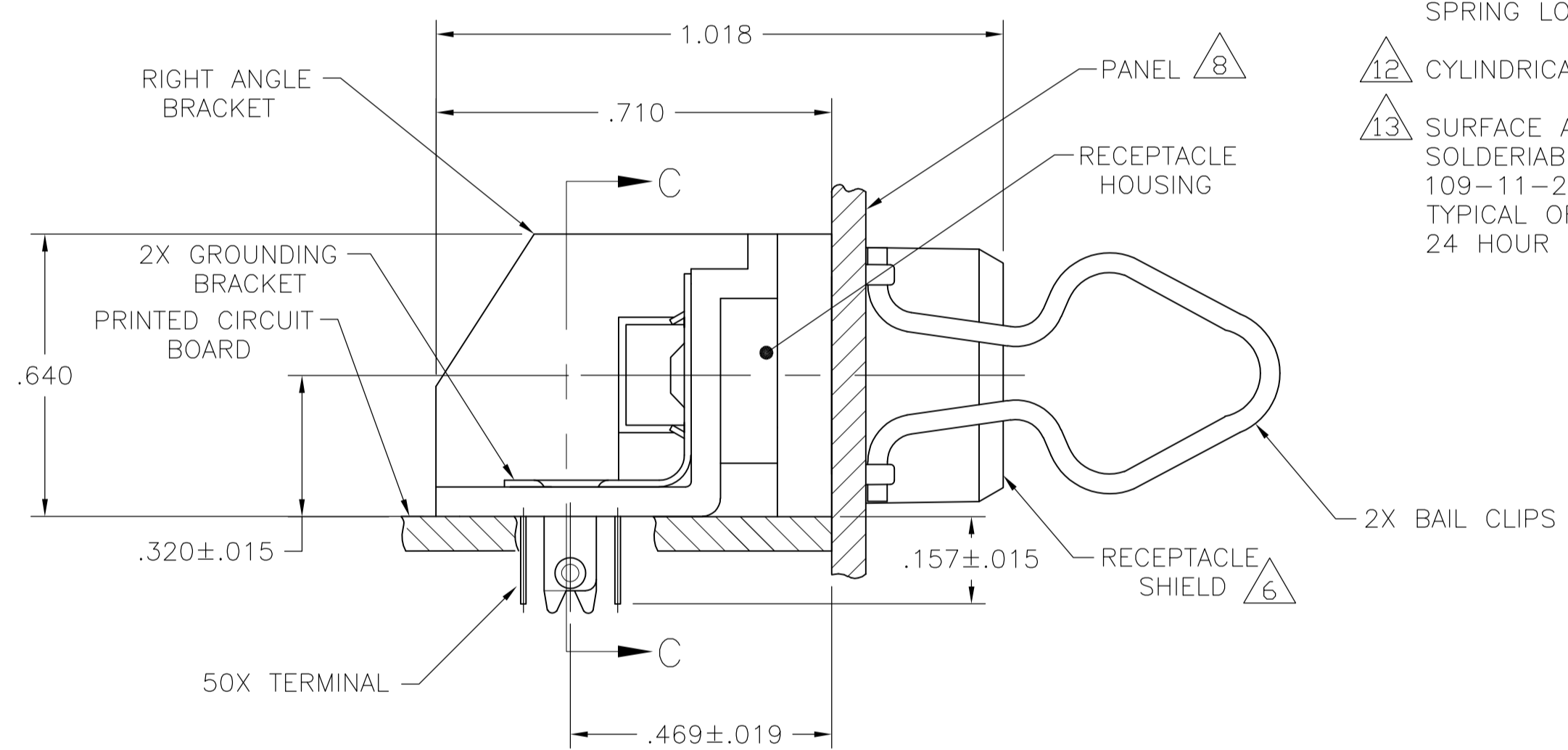

SIDE VIEW A-A REAR PANEL MOUNTING DETAIL SHOWN FOR REFERENCE ONLY

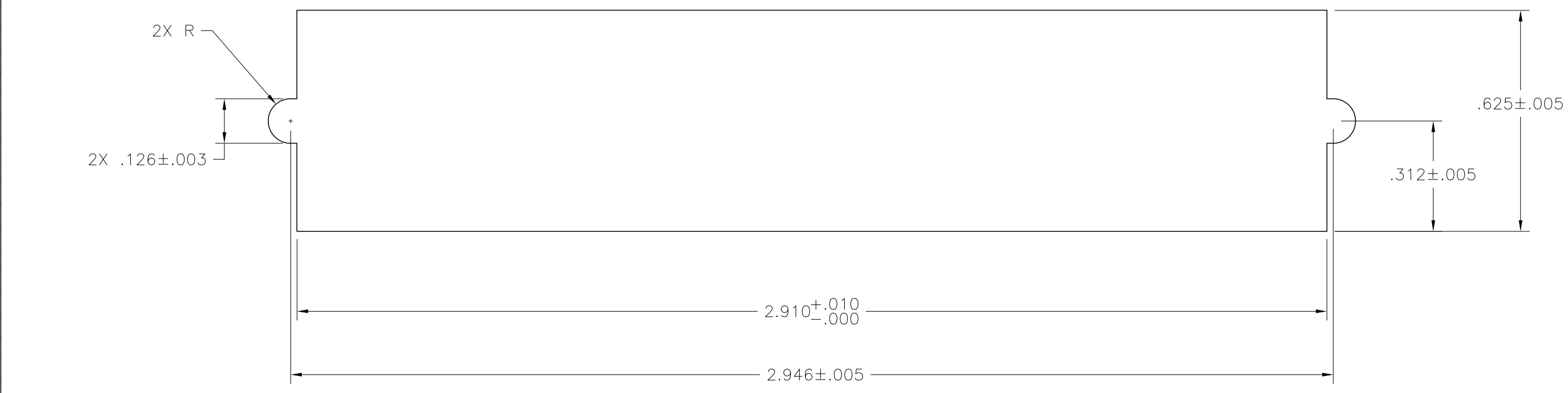

SUGGESTED REAR PANEL MOUNTING CUTOUT DIMENSIONS

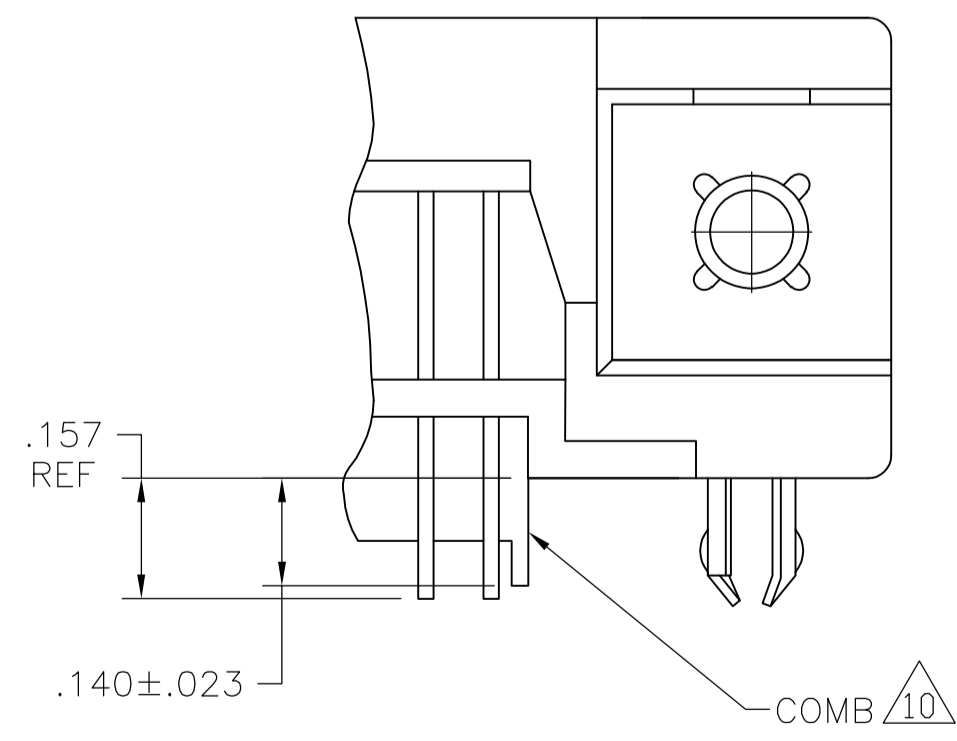

DETAIL B

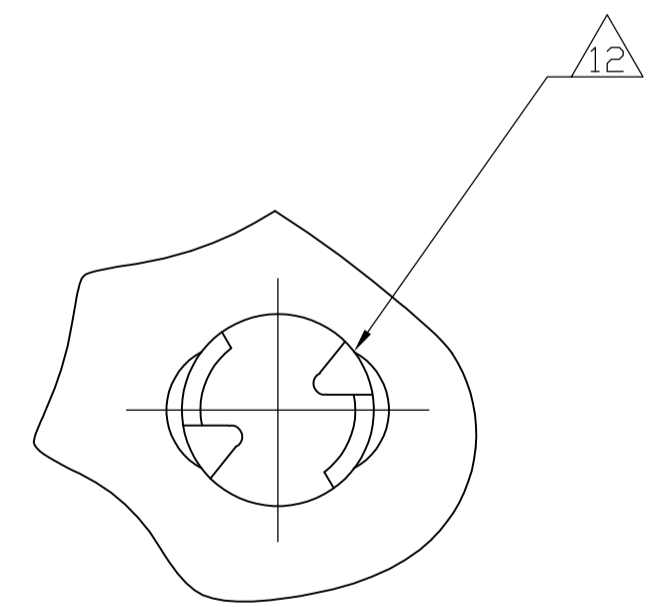

A	STANDARD	5555057-1
DETAIL	ORIENTATION	PART NUMBER

THIS DRAWING IS A CONTROLLED DOCUMENT.		DIN B MCMMASTER 24AUG05	Tyco Electronics Corporation Harrisburg, PA 17105-3608	
DIMENSIONS: INCHES		CIK W MILLHIMES 24AUG05	NAME	
TOLERANCES UNLESS OTHERWISE SPECIFIED:		APVD W MILLHIMES 24AUG05	RECEPTACLE ASSEMBLY, 50 POSITION, RIGHT ANGLE, SHIELDED, BAIL LOCK W/ GROUND, PANEL MOUNTING	
0 PLC ± -	1 PLC ± -	PRODUCT SPEC	SIZE	CAGE CODE
2 PLC ± -	3 PLC ± -	APPLICATION SPEC	A1	00779
4 PLC ± -	ANGLES ± -	WEIGHT	SCALE	DRAWING NO
1	1	—	4:1	5555057
CUSTOMER DRAWING		RESTRICTED TO	SHEET	REV
		—	1 OF 1	B

# Mouser Electronics

Authorized Distributor

Click to View Pricing, Inventory, Delivery & Lifecycle Information:

[TE Connectivity:](#)

[5555057-1](#)