

## Profile - UM 45-PROFIL 235CM - 2735441

Please be informed that the data shown in this PDF Document is generated from our Online Catalog. Please find the complete data in the user's documentation. Our General Terms of Use for Downloads are valid (<http://phoenixcontact.com/download>)



Press-drawn section housings, Basic profile, open, profile width (internal): 41.85 mm, length: 2350 mm, height: 44.8 mm, cross connection: without bus connector

### Your advantages

- UM ...-SES lateral element offers options for labeling with Phoenix Contact marking material
- Fast mounting
- Flexible size and shape
- Inexpensive as a result of reducing the number of separate housing parts
- High degree of mechanical stability by screwing the lateral elements to the profile
- The UMK-BF mounting flange enables modules to be mounted directly on the wall
- Cable fixing by means of UM ...-SEK lateral element (fixed using cable binders, not supplied as standard)



### Key Commercial Data

Packing unit	1 pc
GTIN	
GTIN	4017918589554

### Technical data

#### Product properties

Brief article description	Profile
Type	UM 45-PROFIL 235CM
Order No.	2735441
Housing type	Press-drawn section housings
Type	Basic profile

#### Dimensions

Length [ l ]	235 cm
Profile width (external)	44.8 mm
Profile width (internal)	41.85 mm

## Profile - UM 45-PROFIL 235CM - 2735441

### Technical data

#### Dimensions

Height	44.8 mm
Depth [ d ]	18.95 mm

#### Material specifications

Housing material	PVC
------------------	-----

#### Ambient conditions

Ambient temperature (operation)	-15 °C ... 50 °C
---------------------------------	------------------

#### Packaging specifications

Pieces per package	1
Denomination packing units	Pcs.

#### Standards and Regulations

Flammability rating according to UL 94	V0
--	----

#### Environmental Product Compliance

China RoHS	Environmentally friendly use period: unlimited = EFUP-e
	No hazardous substances above threshold values

### Drawings

## Profile - UM 45-PROFIL 235CM - 2735441

Dimensional drawing

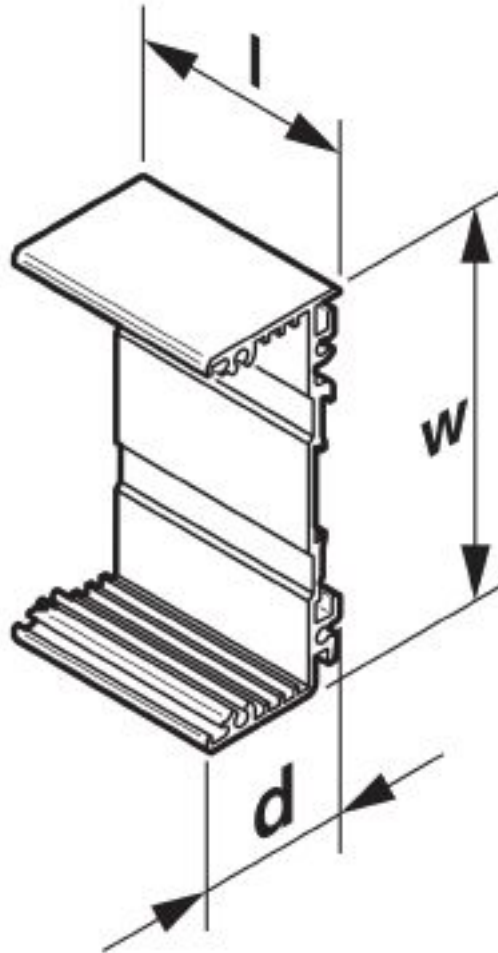

### Classifications

eCl@ss

eCl@ss 10.0.1	27182701
eCl@ss 4.0	27180400
eCl@ss 4.1	27180400
eCl@ss 5.0	27180500
eCl@ss 5.1	27180500
eCl@ss 6.0	27180800
eCl@ss 7.0	27182701
eCl@ss 8.0	27182701
eCl@ss 9.0	27182701

ETIM

ETIM 2.0	EC001031
----------	----------

# Profile - UM 45-PROFIL 235CM - 2735441

## Classifications

### ETIM

ETIM 3.0	EC001031
ETIM 4.0	EC001031
ETIM 5.0	EC002779
ETIM 6.0	EC002779
ETIM 7.0	EC002779

### UNSPSC

UNSPSC 6.01	31261501
UNSPSC 7.0901	31261501
UNSPSC 11	31261501
UNSPSC 12.01	31261501
UNSPSC 13.2	31261501
UNSPSC 18.0	31261501
UNSPSC 19.0	31261501
UNSPSC 20.0	31261501
UNSPSC 21.0	31261501

## Approvals

### Approvals

---

Approvals

EAC

---

Ex Approvals

---

### Approval details

EAC		B.01687
-----	---	---------

## Accessories

Accessories

Device marking

## Profile - UM 45-PROFIL 235CM - 2735441

### Accessories

Contact marker - zack marker strip - SS-ZB WH - 5031171



Contact marker - zack marker strip, Strip, white, unlabeled, can be labeled with: CMS-P1-PLOTTER, mounting type: snap into flat marker groove, lettering field size: 20 mm x 8 mm, Number of individual labels: 5

Contact marker - zack marker strip - SS-ZB YE - 5031650



Contact marker - zack marker strip, Strip, yellow, unlabeled, can be labeled with: CMS-P1-PLOTTER, mounting type: snap into flat marker groove, lettering field size: 20 mm x 8 mm, Number of individual labels: 5

### Mounting material

Foot element - UM 25/45-FEO 200 - 2959434



Foot element, is inserted in the profile housing, limit stop with screw. Mounted at right angles to the NS 35/7.5 DIN rail

Mounting flange - UMK-BF - 2976077



Mounting flange, for mounting directly on the wall

### Panel mounting base side part

Electronic housing - UM 45-SEAS - 2907554



Panel mounting base, Side cover, with snap-on foot, height: 45 mm, color: green, Note: when using this lateral element, profile length = PCB length.

Phoenix Contact 2020 © - all rights reserved  
<http://www.phoenixcontact.com>

PHOENIX CONTACT GmbH & Co. KG  
Flachsmarktstr. 8  
32825 Blomberg  
Germany  
Tel. +49 5235 300  
Fax +49 5235 3 41200  
<http://www.phoenixcontact.com>