

42M048C

Ø 42 mm • RoHS Compliant • 83.8 mNm

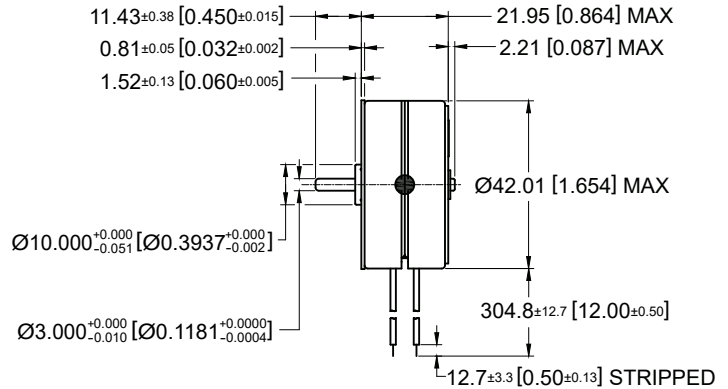
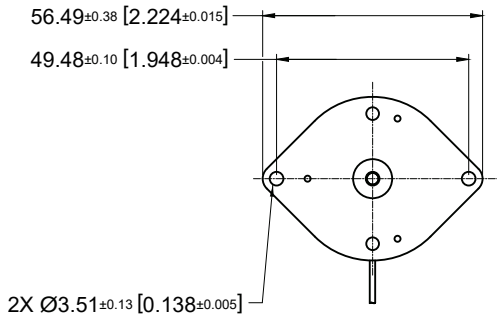

Dimensions in mm. [inches]

Electrical Data	42M048C••				Unit
	1U Unipolar	2U Unipolar	1B Bipolar	2B Bipolar	
1 Operating Voltage	5	12	5	12	VDC
2 Resistance per Phase, ± 10%	9.1	52.4	9.1	52.4	Ohms
3 Inductance per Phase, typ	8.1	51.7	16.7	85.7	mH
4 Rated Current per Phase *	0.55	0.23	0.55	0.23	A
Coil Independent Parameters					
5 Holding Torque, MIN *	66.2 (9.4)	66.2 (9.4)	83.8 (11.9)	83.8 (11.9)	mNm (oz-in)
6 Detent Torque, Max		12.7 (1.8)			mNm (oz-in)
7 Rotor Inertia		12.5 (0.068)			gcm ² (oz-in ²)
8 Step Angle		7.5			Degree
9 Absolute accuracy 2 ph. On, Full step		± 0.5			Degree
10 Steps per Revolution		48.0			
11 Ambient Temp Range (operating)		-20 to +70 (-4 to +158)			°C (°F)
12 Maximum Coil Temperature		130 (266)			°C (°F)
13 Bearing Type		Sintered Bronze Sleeve			
14 Insulation Resistance at 500 VDC		100.0			Mohms
15 Dielectric Withstanding Voltage		650 VRMS for 2 seconds			VAC
16 Weight		145 (5.1)			g (oz)
17 Leadwire		AWG #26, UL1430 (105° C, 300 V)			

Note: All motor data values at 20° C unless otherwise specified

* Engergize at rated current, 2-Phase On

