

36V DC-DC Boost Converter

General Description

The RT8580 is a high performance, low noise, DC-DC Boost Converter with an integrated 0.5A, 1Ω internal switch. The RT8580's input voltage ranges from 3V to 5.5V, and it can support the output voltage up to 40V. When used in optical receiver applications requiring 80V to drive the APD (Avalanche Photo Diode), the output voltage of the RT8580 can be doubled up by a typical voltage doubler circuit. The RT8580 adapts fixed frequency, current mode PWM control loop to regulate the output voltage with fast transient response and cycle-by-cycle current limit protection. The protection features of the RT8580 include : 1) input under-voltage lockout, 2) output over-voltage protection, and 3) over-temperature protection. The soft-start function and PWM loop compensation is built-in internally to save external soft-start capacitor and PWM loop compensation components. By operating at 500kHz switching frequency, the RT8580 system board can be made compact to achieve low system BOM cost. The RT8580 is available in the tiny package type SOT-23-6.

Marking Information

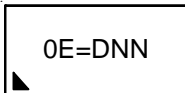

0E= : Product Code
DNN : Date Code

Features

- Input Operating Range : 3V to 5.5V
- Wide Output Range : VCC to 40V
- Internal Power N-MOSFET Switch
- 500kHz Fixed Switching Frequency
- Minimize the External Component Counts
- Internal Soft-Start
- Internal Compensation
- Under-Voltage Lockout Protection
- Over-Temperature Protection
- RoHS Compliant and Halogen Free

Applications

- Cellular Phones
- Digital Cameras
- Portable Instruments
- Avalanche Photodiode Biasing

Ordering Information

RT8580□□

- Package Type
E : SOT-23-6
- Lead Plating System
G : Green (Halogen Free and Pb Free)

Note :

Richtek products are :

- ▶ RoHS compliant and compatible with the current requirements of IPC/JEDEC J-STD-020.
- ▶ Suitable for use in SnPb or Pb-free soldering processes.

Simplified Application Circuit

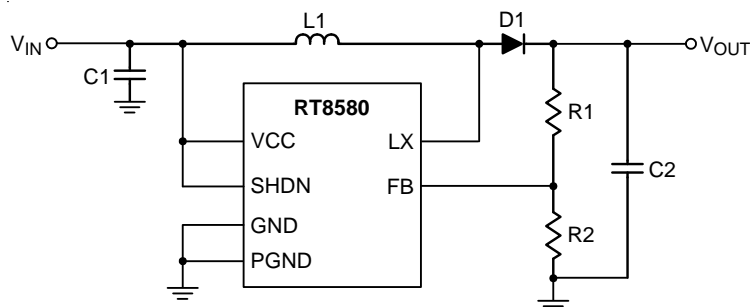

Pin Configuration

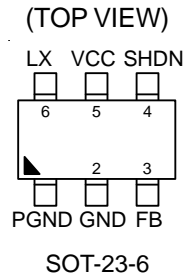

Functional Pin Description

Pin No.	Pin Name	Pin Function
1	PGND	Power ground.
2	GND	Ground.
3	FB	Feedback voltage input. Connect a resistor to GND to setting the current.
4	SHDN	Shutdown control input. Apply a logic-low voltage to SHDN to shut down the device. Connect SHDN to VIN for normal operation. Ensure that SHDN is not greater than the input voltage, VCC.
5	VCC	Supply voltage input.
6	LX	Switch node.

Functional Block Diagram

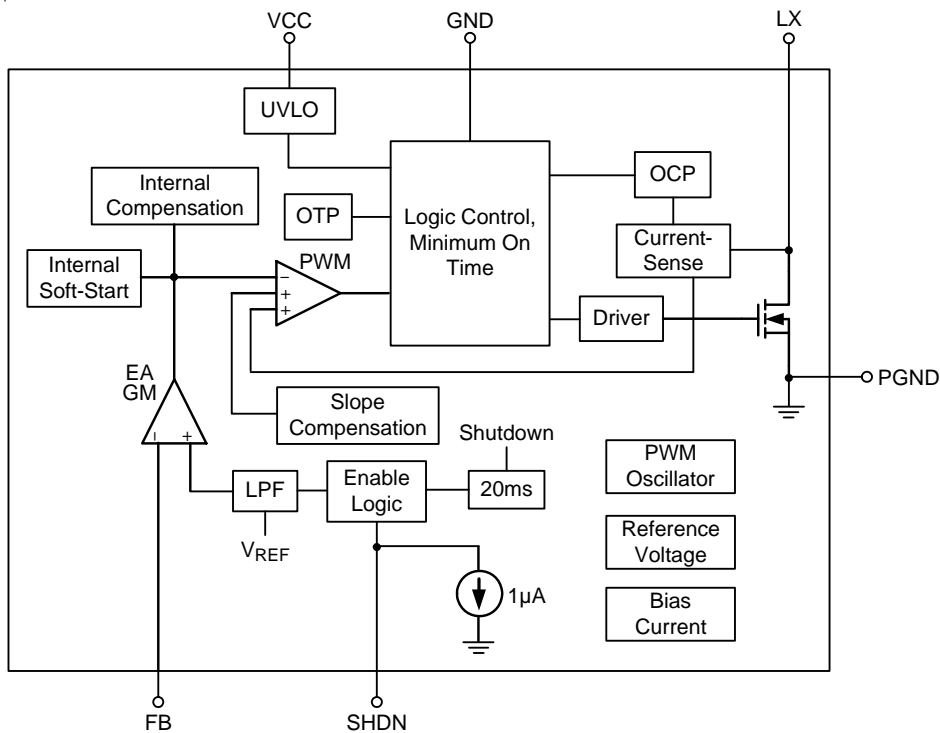

Operation

The RT8580 is a constant frequency, current mode Boost regulator. In normal operation, the N-MOSFET is turned on when the PWM control circuit is set by the oscillator. As the N-MOSFET is on, the inductor current ramps up. The N-MOSFET will be turned off when the inductor current hits the level set by the PWM control loop. After the N-MOSFET is turned off, the inductor current will ramp down through the external catch diode until the OSC sets high for the next switching cycle and the next cycle repeats.

The operation of the RT8580 can be better understood by referring to the block diagram. The voltage at the output of the error amplifier is an amplified version of the difference between the 1.25V reference voltage and the output feedback voltage. If the feedback voltage drops below (above) 1.25V, the output of the error amplifier increases (decreases). This results in higher (lower) PWM turn on duty and thus higher (lower) inductor peak current flowing through the power FET. By this control loop operation, the increased (decreased) power will be delivered to the output to bring up (down) the output feedback voltage back to 1.25V.

When the RT8580 is enabled by SHDN pin, the internal V_{REF} ramps up to the target voltage in a specific time period. There is also a built-in soft-start function. Both ensure that the output voltage rises slowly to reduce the input inrush current.

The protection features of the RT8580 include : 1) input under-voltage lockout, 2) output over-voltage protection, and 3) over-temperature protection. When the input voltage is lower than the UVLO threshold, the RT8580 will be turned off. There is a 100mV hysteresis for the UVLO control. When the junction temperature exceeds 150°C, the over-temperature protection function will shut down the switching operation. Once the junction temperature cools down by approximately 25°C, the converter will automatically resume switching.

Absolute Maximum Ratings (Note 1)

- VCC, SHDN, FB to GND ----- -0.3V to 6V
- LX to GND ----- -0.3V to 50V
- Power Dissipation, P_D @ T_A = 25°C
 - SOT-23-6 ----- 0.48W
- Package Thermal Resistance (Note 2)
 - SOT-23-6, θ_{JA} ----- 208.2°C/W
- Junction Temperature ----- 150°C
- Lead Temperature (Soldering, 10 sec.) ----- 260°C
- Storage Temperature Range ----- -65°C to 150°C
- ESD Susceptibility (Note 3)
 - HBM (Human Body Model) ----- 2kV
 - MM (Machine Model) ----- 200V

Recommended Operating Conditions (Note 4)

- Input Voltage, VCC ----- 3V to 5.5V
- Junction Temperature Range ----- -40°C to 125°C
- Ambient Temperature Range ----- -40°C to 85°C

Electrical Characteristics

(V_{CC} = 3.3V, T_A = 25°C, unless otherwise specified)

Parameter		Symbol	Test Conditions	Min	Typ	Max	Unit
Overall							
Under-Voltage Lockout Threshold		V _{UVLO}		--	2	2.4	V
VCC Quiescent Current		I _Q		0.6	0.8	1.2	mA
VCC Shutdown Current			SHDN = 0V	--	2	5	μA
Shutdown Input Current		I _{SHDN}		--	--	2	μA
SHDN Threshold Voltage	Logic-High	V _{IH}		1.4	--	--	V
	Logic-Low	V _{IL}		--	--	0.5	
Oscillator							
Switching Frequency		f _{SW}		450	500	550	kHz
Maximum Duty in Steady State Operation		D _{MAX}		91	93	97	%
Line Regulation			V _{CC} = 3.3V to 4.3V	-1.5	--	1.5	%
Feedback Reference Voltage				1.22	1.25	1.28	V
Feedback Input Current		I _{FB}	V _{FB} = V _{FB_SET}	--	100	500	nA
LX On-Resistance		R _{DS(ON)}		--	0.7	1	Ω
LX Leakage Current			V _{LX} = 40V	--	--	4	μA
Switch Current Limit		I _{LIM}		--	330	--	mA

Parameter	Symbol	Test Conditions	Min	Typ	Max	Unit
Thermal Protection						
Thermal Shutdown Temperature	T _{SD}		--	150	--	°C
Thermal Shutdown Hysteresis	ΔT _{SD}		--	25	--	°C

Note 1. Stresses beyond those listed “Absolute Maximum Ratings” may cause permanent damage to the device. These are stress ratings only, and functional operation of the device at these or any other conditions beyond those indicated in the operational sections of the specifications is not implied. Exposure to absolute maximum rating conditions may affect device reliability.

Note 2. θ_{JA} is measured under natural convection (still air) at T_A = 25°C with the component mounted on a high effective-thermal-conductivity four-layer test board on a JEDEC 51-7 thermal measurement standard.

Note 3. Devices are ESD sensitive. Handling precaution is recommended.

Note 4. The device is not guaranteed to function outside its operating conditions.

Typical Application Circuit

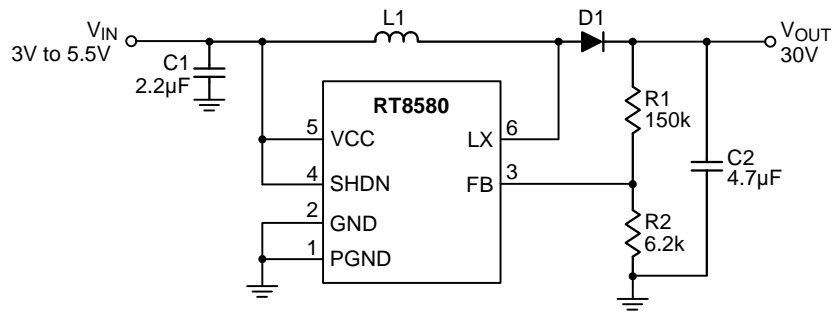

Typical Operating Characteristics

Efficiency vs. Load Current

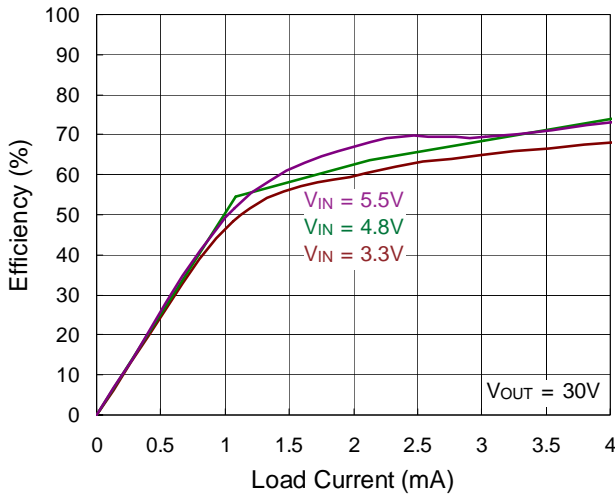

Quiescent Current vs. Input Voltage

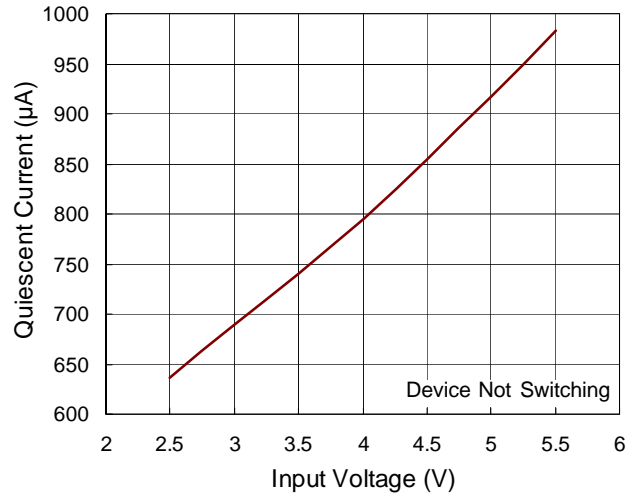

No Load Quiescent Current vs. Input Voltage

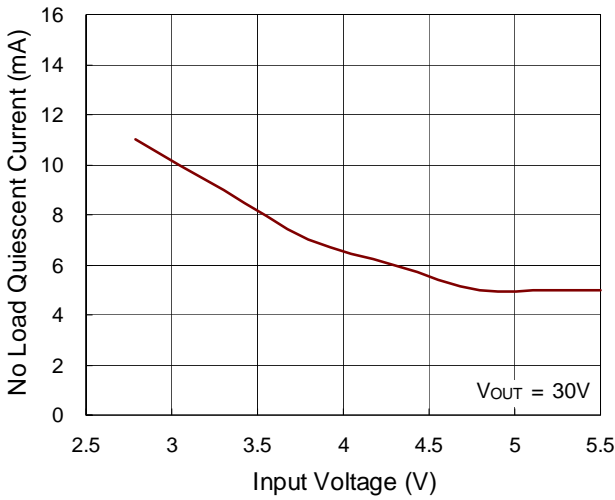

Quiescent Current vs. Temperature

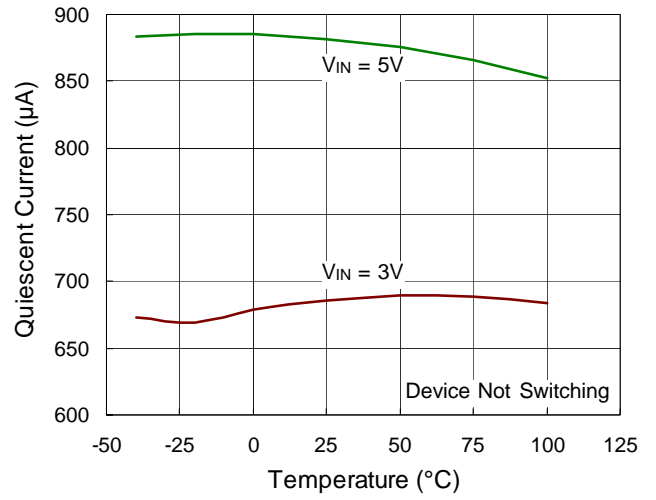

Switching Frequency vs. Temperature

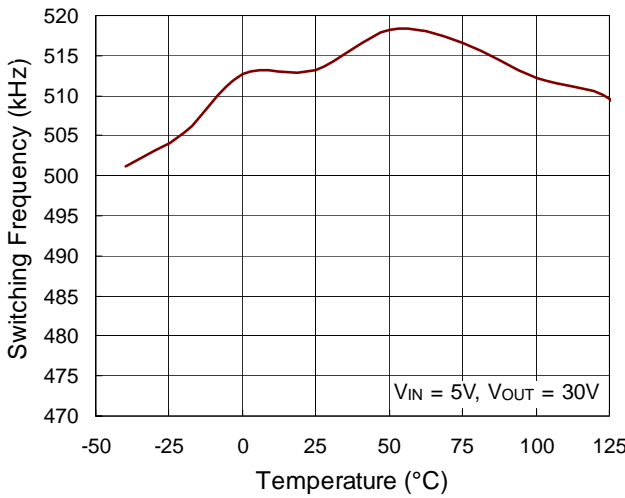

Feedback Voltage vs. Temperature

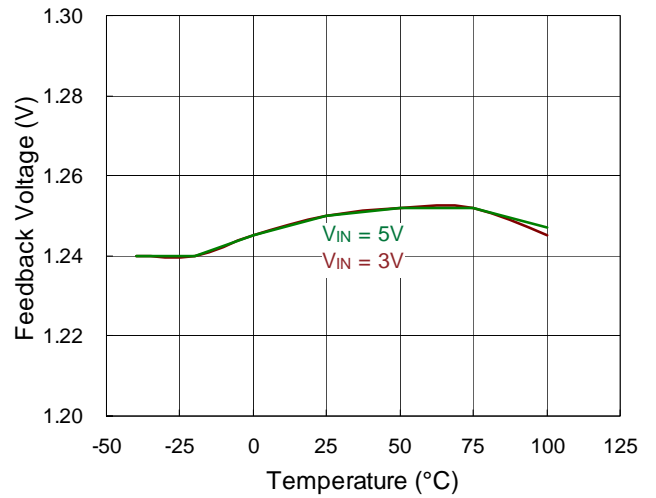

Light Load Switching

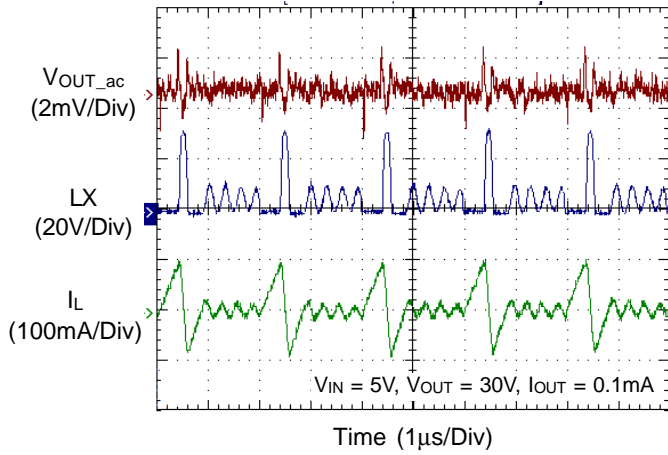

Heavy Load Switching

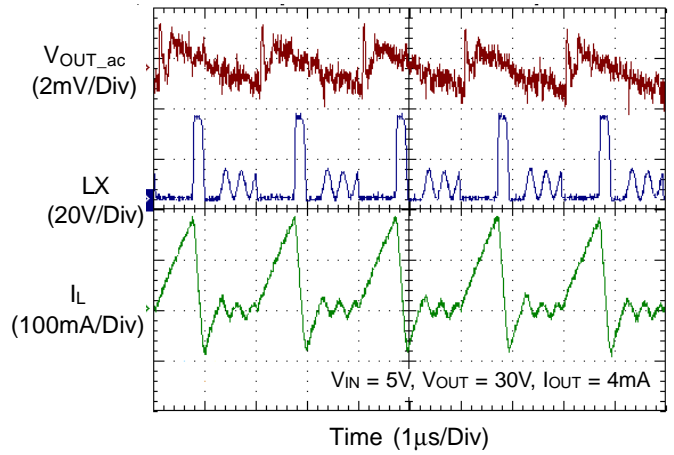

Power On from SHDN

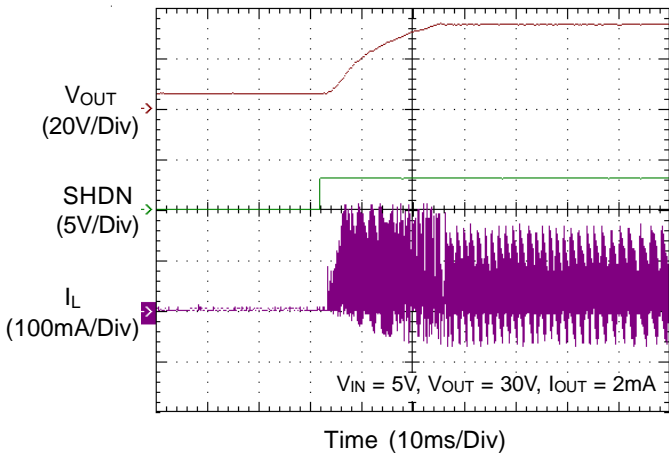

Power Off from SHDN

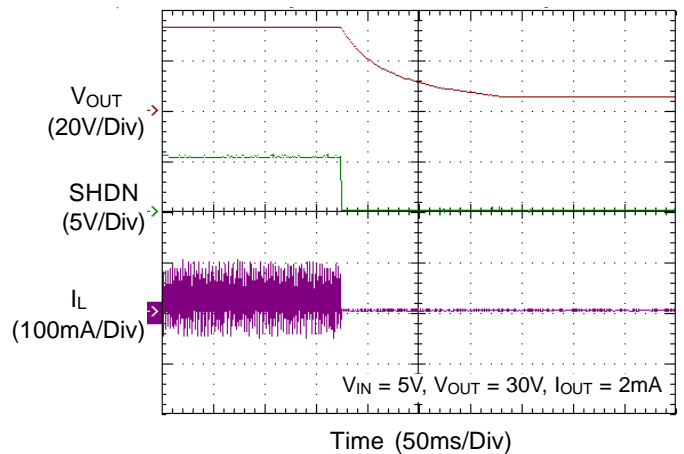

Load Transient Response

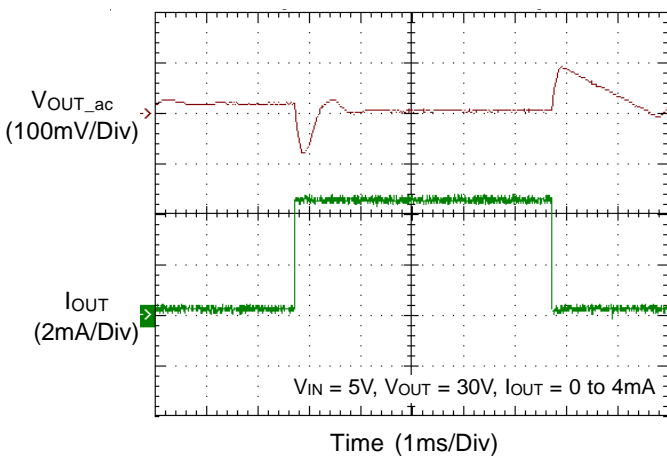

Application Information

The RT8580 current-mode PWM controllers operate in wide range of DC-DC conversion applications for boost. This converter provides low noise, high output voltages. Other features include shutdown, fixed 500kHz PWM oscillator, and an input range : 3V to 5.5V for the RT8580.

The RT8580 operates in discontinuous mode in order to reduce the switching noise at the output. Other continuous mode Boost converters generate a large voltage spike at the output when the LX switch turns on because there is a conduction path between the output, diode, and switch to ground during the time needed for the diode to turn off.

SHDN Input

The SHDN pin provides shutdown control. Connect SHDN to VCC for normal operation. To disable the device, connect SHDN to GND.

Constant Output Voltage Control

The output voltage of the RT8580 is fixed at 30V. The output voltage is set by two external resistors (R1 and R2). First select the value of R2 in the 5kΩ to 50kΩ range. R1 is then given by :

$$R1 = R2 \left(\frac{V_{OUT}}{V_{REF}} - 1 \right)$$

where V_{REF} is 1.25V

Determining Peak Inductor Current

If the Boost converter remains in the discontinuous mode of operation, then the approximate peak inductor current, I_{LPEAK} , is represented by the formula below :

$$I_{LPEAK} = \sqrt{\frac{2T_S(V_{OUT} - V_{IN})I_{OUT}}{\eta L}}$$

where T_S is the period, V_{OUT} is the output voltage, V_{IN} is the input voltage, I_{OUT} is the output current, and η is the efficiency of the boost converter.

Inductor Selection

The recommended value of inductor for 30V, 22μH is the recommended inductor value when the output voltage is 30V and the input voltage is 5V. In general, the inductor

should have a current rating greater than the current-limit value. The inductor saturation current rating should be considered to cover the inductor peak current.

Soft-Start

The function of soft-start is made for suppressing the inrush current to an acceptable value at the beginning of power on. The RT8580 provides a built-in soft-start function by clamping the output voltage of error amplifier so that the duty cycle of the PWM will be increased gradually in the soft-start period.

Current Limiting

The current flow through inductor as charging period is detected by a current sensing circuit. As the value comes across the current limiting threshold, the N-MOSFET will be turned off so that the inductor will be forced to leave charging stage and enter discharging stage. Therefore, the inductor current will not increase over the current limiting threshold.

Diode Selection

The RT8580's high switching frequency demands a high-speed rectifier. Schottky diodes are recommended for most applications because of their fast recovery time and low forward-voltage drop. Ensure that the diode's peak current rating is greater than or equal to the peak inductor current. Also, the diode reverse breakdown voltage must be greater than V_{OUT} .

Input Capacitor Selection

Low ESR ceramic capacitors are recommended for input capacitor applications. Low ESR will effectively reduce the input voltage ripple caused by switching operation. A 4.7μF capacitor is sufficient for most applications. Nevertheless, this value can be decreased for lower output current requirement. Another consideration is the voltage rating of the input capacitor which must be greater than the maximum input voltage.

Over-Temperature Protection

The RT8580 has Over-Temperature Protection (OTP) function to prevent the excessive power dissipation from overheating. The OTP function will shut down switching operation when the die junction temperature exceeds 150°C. The chip will automatically start to switch again when the die junction temperature cools off.

Thermal Considerations

The junction temperature should never exceed the absolute maximum junction temperature $T_{J(MAX)}$, listed under Absolute Maximum Ratings, to avoid permanent damage to the device. The maximum allowable power dissipation depends on the thermal resistance of the IC package, the PCB layout, the rate of surrounding airflow, and the difference between the junction and ambient temperatures. The maximum power dissipation can be calculated using the following formula :

$$P_{D(MAX)} = (T_{J(MAX)} - T_A) / \theta_{JA}$$

where $T_{J(MAX)}$ is the maximum junction temperature, T_A is the ambient temperature, and θ_{JA} is the junction-to-ambient thermal resistance.

For continuous operation, the maximum operating junction temperature indicated under Recommended Operating Conditions is 125°C. The junction-to-ambient thermal resistance, θ_{JA} , is highly package dependent. For a SOT-23-6, the thermal resistance, θ_{JA} , is 208.2°C/W on a standard JEDEC 51-7 high effective-thermal-conductivity four-layer test board. The maximum power dissipation at $T_A = 25^\circ\text{C}$ can be calculated as below :

$$P_{D(MAX)} = (125^\circ\text{C} - 25^\circ\text{C}) / (208.2^\circ\text{C/W}) = 0.48\text{W for a SOT-23-6 package.}$$

The maximum power dissipation depends on the operating ambient temperature for the fixed $T_{J(MAX)}$ and the thermal resistance, θ_{JA} . The derating curves in Figure 1 allows the designer to see the effect of rising ambient temperature on the maximum power dissipation.

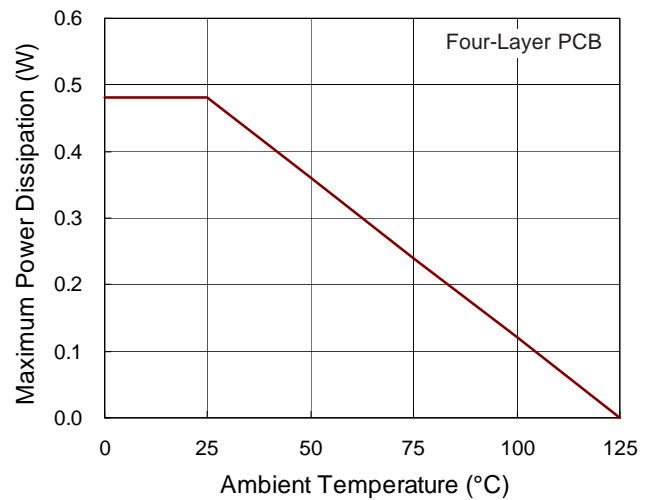

Figure 1. Derating Curve of Maximum Power Dissipation

Layout Considerations

PCB layout is very important when designing power switching converter circuits. Some recommended layout guide lines are as follows :

The power components L1, D1 and C2 must be placed as close to each other as possible to reduce the ac current loop area. The PCB trace between power components must be as short and wide as possible due to large current flow through these traces during operation.

Place L1 and D1 as close to the LX Pin as possible. The trace should be as short and wide as possible.

The input capacitor C1 must be placed as close to the VCC pin as possible.

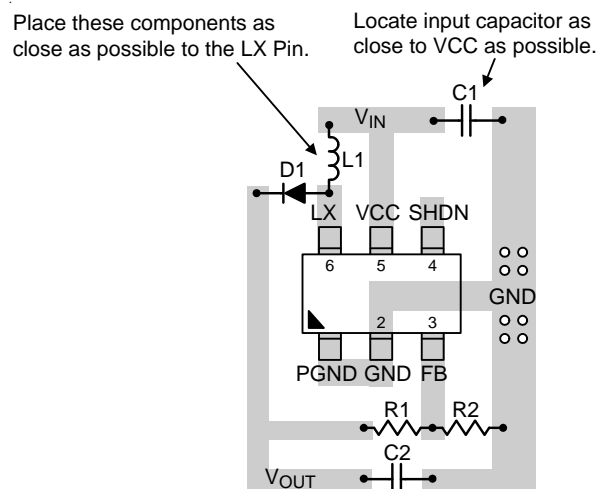
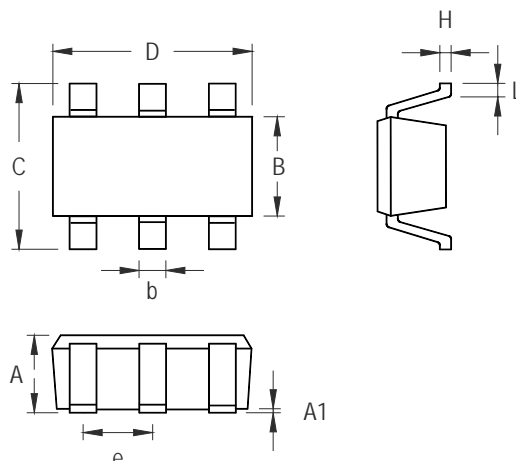

Figure 2. PCB Layout Guide

Outline Dimension



Symbol	Dimensions In Millimeters		Dimensions In Inches	
	Min	Max	Min	Max
A	0.889	1.295	0.031	0.051
A1	0.000	0.152	0.000	0.006
B	1.397	1.803	0.055	0.071
b	0.250	0.560	0.010	0.022
C	2.591	2.997	0.102	0.118
D	2.692	3.099	0.106	0.122
e	0.838	1.041	0.033	0.041
H	0.080	0.254	0.003	0.010
L	0.300	0.610	0.012	0.024

SOT-23-6 Surface Mount Package

Richtek Technology Corporation

14F, No. 8, Tai Yuen 1st Street, Chupei City
 Hsinchu, Taiwan, R.O.C.
 Tel: (8863)5526789

Richtek products are sold by description only. Richtek reserves the right to change the circuitry and/or specifications without notice at any time. Customers should obtain the latest relevant information and data sheets before placing orders and should verify that such information is current and complete. Richtek cannot assume responsibility for use of any circuitry other than circuitry entirely embodied in a Richtek product. Information furnished by Richtek is believed to be accurate and reliable. However, no responsibility is assumed by Richtek or its subsidiaries for its use; nor for any infringements of patents or other rights of third parties which may result from its use. No license is granted by implication or otherwise under any patent or patent rights of Richtek or its subsidiaries.