

DO NOT SCALE FROM THIS PRINT

- ⊕ REPRESENTS A CRITICAL DIMENSION.
- MINIMUM PUSHOUT FORCE: .5LB (8 OZ).
- ONE POSITION WILL BE LOST FOR EVERY CUT MADE ON A SOCKET STRIP.
- TUBE PACKAGE POSITIONS 5-50 ONLY. POSITIONS 2-4 ARE TO BE PLACED IN ANTISTATIC BUBBLE BAGS P/N ASBBLT4X5.5.
- SHEAR TAILS TO DIMENSIONS SHOWN.
- NOTE DELETED.
- TAIL SIDE ENDWALL AFTER CUTTING: .0160[0.406]±.0025[0.064].
- VOID CORES MAY NOT BE PRESENT.
- HAND FILL USE C-106-01-XX.  
CAN'T HAND FILL -STL & -LTL-PLATING.  
AUTOMATION USE C-106-22-XX. C-106-02-XX CAN BE SUBBED FOR C-106-22-XX.  
FOR -LTL AND -STL PLATING USE SUB-C-106-X2-XTL PINS
- ⊕10. MAX CUT FLASH: .010[0.25] X .020[0.51] (HEIGHT X WIDTH) WITH NO FLASH ALLOWED IN HOLES OR EXTENDING BELOW LEADS.
- ⊕11. MAX BURR: .005[.13].
- ALL -PA OPTION PARTS SHIP IN EIA-960 TRAYS.
- DOES NOT APPLY TO -BE END OPTION.
- TR OPTION ORDERS INVOLVING PARTIAL REEL QUANTITIES MAY BE PACKAGED ACCORDING TO THE SAMTEC PACKAGING EFFICIENCY STANDARDS (SPES) FOUND ON WWW.SAMTEC.COM.
- FR OPTIONS WILL BE SHIPPED AT THE MAX QUANTITY PER REEL, BASED ON OPTIONS SELECTED.

CLP-1XX-XX-XXX-D-XX

No OF POSITIONS PER ROW  
-02 THRU -50

LEAD STYLE SPEC  
-02: SURFACE MOUNT  
(USE C-106-X2-XXX OR SUB-C-106-X2-XXX)  
(SEE NOTE 9)

OPTION  
-P: PICK & PLACE PAD (USE LMP-01)  
(AVAILABLE ON POSITION -05 THRU -50 ONLY)  
(NOT AVAILABLE WITH -PA OR -K OPTIONS)  
(SEE FIG 3, SHT 2)  
-A: ALIGNMENT PIN (USE CLP-XX-D-XX)  
(NOT AVAILABLE WITH -PA OPTION)  
(SEE FIG 2, SHT 2)  
-TR: TAPE AND REEL (SEE NOTE 14)  
-BE: BOTTOM ENTRY ONLY (USE CLP-XX-DBE-XX)  
-PA: PICK & PLACE PAD WITH ALIGNMENT PINS  
(NOT AVAILABLE WITH -P, -A, OR -K OPTIONS)  
(SEE SHT 2, TABLE 3)(SEE NOTE 12)  
-K: POLYIMIDE FILM PAD (AVAILABLE ON -03 THRU -50 POSITIONS. USE K-DOT-.157-.250-.005) (AVAILABLE ON -02 POSITIONS. USE K-DOT-.118-.219-.005) (SEE FIG 5, SHT 2)(NOT AVAILABLE WITH -P OR -PA OPTIONS)  
-FR: FULL REEL QTY. TAPE & REEL (SEE NOTE 15)

BODY SPEC  
-D: DOUBLE ROW  
(USE CLP-XX-D)

PLATING SPEC  
-F: 3μ" FLASH SELECTIVE GOLD IN CONTACT AREA MATTE TIN ON TAIL  
-L: 10μ" LIGHT SELECTIVE GOLD IN CONTACT AREA MATTE TIN ON TAIL  
-S: 30μ" SELECTIVE GOLD IN CONTACT AREA MATTE TIN ON TAIL  
-G: 10μ" GOLD IN CONTACT AREA 3μ" ON TAIL  
-H: 30μ" HEAVY GOLD IN CONTACT AREA 3μ" ON TAIL  
-LM: 10μ" LIGHT SELECTIVE GOLD IN CONTACT AREA MATTE TIN ON TAIL  
-FM: 3μ" FLASH SELECTIVE GOLD IN CONTACT AREA MATTE TIN ON TAIL  
-SM: 30μ" SELECTIVE GOLD IN CONTACT AREA MATTE TIN ON TAIL  
-LTL: 10μ" LIGHT SELECTIVE GOLD IN CONTACT AREA TIN/LEAD (90/10+/-5%) TAIL (SEE NOTE 9)  
-STL: 30μ" SELECTIVE GOLD IN CONTACT AREA TIN/LEAD (90/10+/-5%) TAIL (SEE NOTE 9)

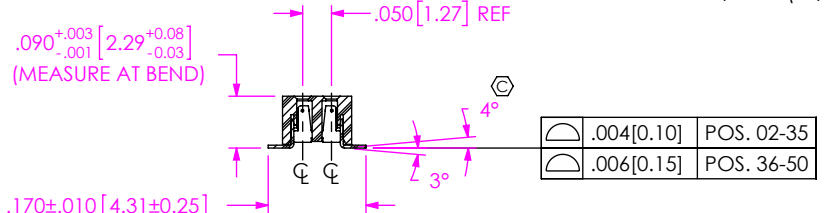
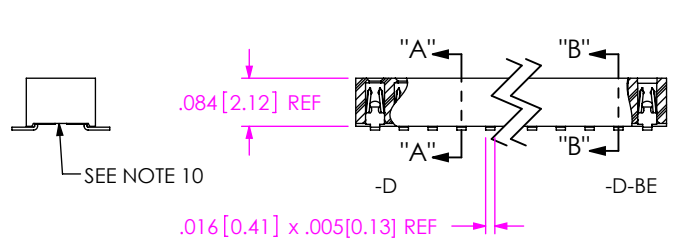
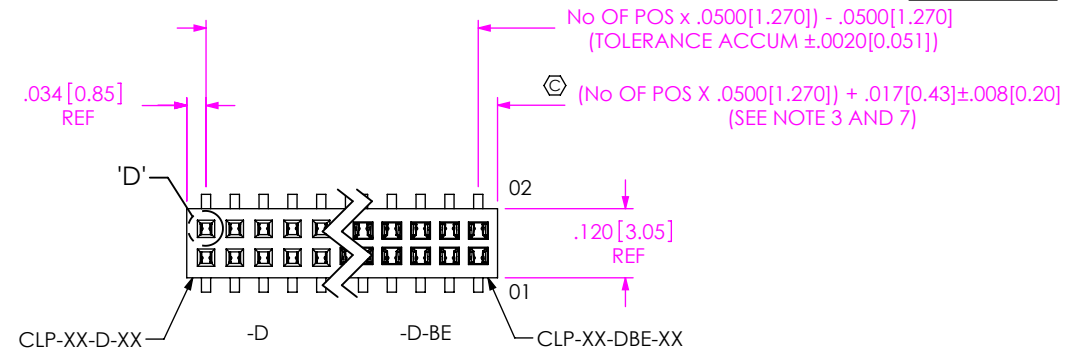
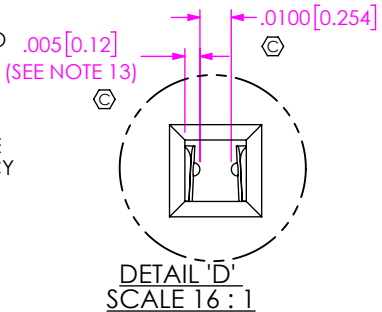

SECTION "B"-"B"  
(-D-BE BODY: CLP-XX-DBE-XX)  
(DIFFERENT AS SHOWN,  
OTHERWISE SAME AS -D BODY)

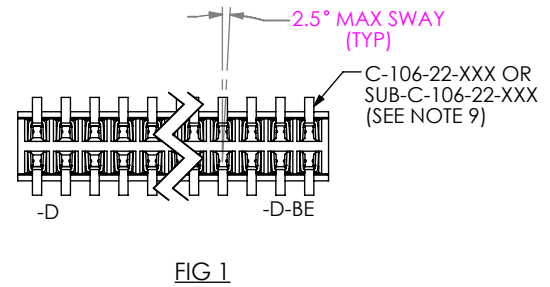
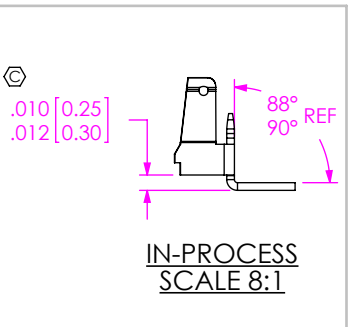

SECTION "A"-"A"  
(-D BODY: CLP-XX-D-XX)

UNLESS OTHERWISE SPECIFIED, DIMENSIONS ARE IN INCHES.  
TOLERANCES ARE:  
DECIMALS ANGLES  
.XX: ±.01 [.3] 2°  
.XXX: ±.005 [.13]  
.XXXX: ±.0020 [.051]

PROPRIETARY NOTE  
THIS DOCUMENT CONTAINS CONFIDENTIAL AND PROPRIETARY INFORMATION AND ALL DESIGN, MANUFACTURING, REPRODUCTION, USE, PATENT RIGHTS AND SALES RIGHTS ARE EXPRESSLY RESERVED BY SAMTEC, INC. THIS DOCUMENT SHALL NOT BE DISCLOSED, IN WHOLE OR PART, TO ANY UNAUTHORIZED PERSON OR ENTITY NOR REPRODUCED, TRANSFERRED OR INCORPORATED IN ANY OTHER PROJECT IN ANY MANNER WITHOUT THE EXPRESS WRITTEN CONSENT OF SAMTEC, INC.

⊕	.004[0.10]	POS. 02-35
⊕	.006[0.15]	POS. 36-50

MATERIAL: DO NOT SCALE DRAWING SHEET SCALE: 3:1

INSULATOR: LCP, UL 94 VO, COLOR: BLACK  
CONTACT: PHOS BRONZE

DESCRIPTION:  
LOW PROFILE .050 x .050 DOUBLE ROW ASM

DWG. NO. CLP-1XX-XX-XXX-D-XX

BY: PURVIS 01/31/1994 SHEET 1 OF 3



AVAILABLE ON POSITIONS 05 THRU 50 ONLY  
 NOTE: "N" = USED MEASURED DIMENSION (REF)  
 "Q" =  $\{("N" - .250[6.35])/2\} \pm .020[0.51]$

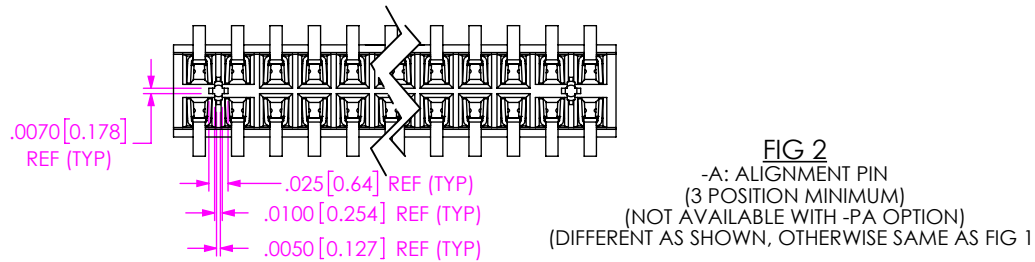
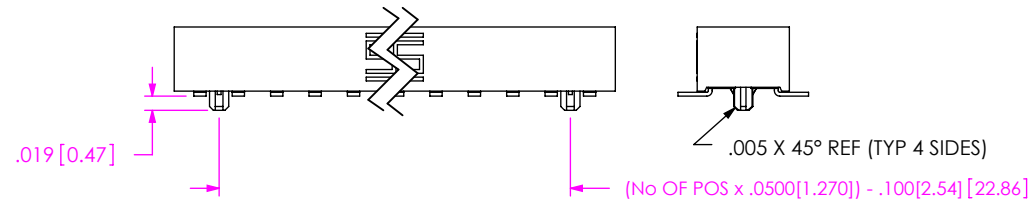

**FIG 2**  
 -A: ALIGNMENT PIN  
 (3 POSITION MINIMUM)  
 (NOT AVAILABLE WITH -PA OPTION)  
 (DIFFERENT AS SHOWN, OTHERWISE SAME AS FIG 1)

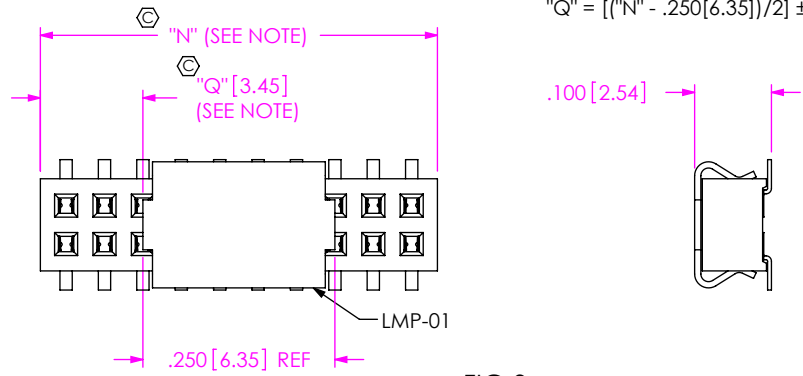

**FIG 3**  
 -P: PICK AND PLACE PAD  
 (AVAILABLE ON POSITION 05 THRU 50 ONLY)  
 (NOT AVAILABLE WITH -PA OR -K OPTIONS)

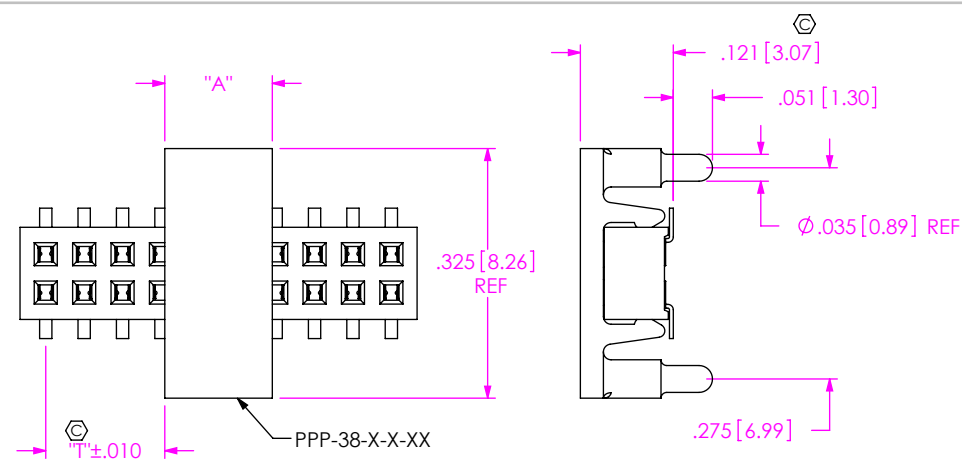

**FIG 4**  
 -PA: PICK & PLACE PAD WITH ALIGNMENT PINS  
 (NOT AVAILABLE WITH -P, -A OR -K OPTIONS)

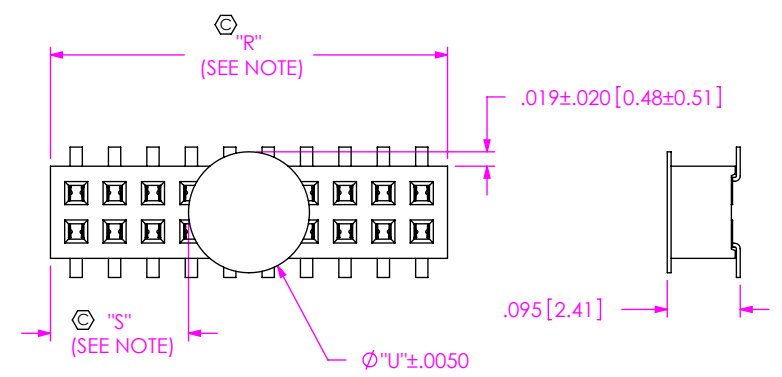

**FIG 5**  
 -K: POLYIMIDE FILM PAD  
 (AVAILABLE ON POSITION 05 THRU 50 ONLY)  
 (NOT AVAILABLE WITH -P OR -PA OPTIONS)  
 NOTE: "R" = USED MEASURED DIMENSION (REF)  
 "S" ON -03 THRU -50 POS =  $\{("R" - .1575[4.000])/2\} \pm .020[0.51]$   
 "S" ON -02 POS =  $\{("R" - .1180[2.997])/2\} \pm .020[0.51]$   
 "U" ON -03 THRU -50 POS = .1575 [4.000]  
 "U" ON -02 POS = .118 [2.997]

TABLE 3				
POS/ROW	PIN COUNT	PAD	"A"	"T"
4-15	ODD	PPP-38-O-4-15	.140 [3.56] REF	$\{((\text{No OF POS} - 1)/2) \times .050[1.27]\} - .070[1.78]$
	EVEN	PPP-38-E-4-15		
16-50	ODD	PPP-38-O-16-50	.280 [7.11] REF	$\{((\text{No OF POS} - 1)/2) \times .050[1.27]\} - .140[3.56]$
	EVEN	PPP-38-E-16-50		

**PROPRIETARY NOTE**  
 THIS DOCUMENT CONTAINS CONFIDENTIAL AND PROPRIETARY INFORMATION AND ALL DESIGN, MANUFACTURING, REPRODUCTION, USE, PATENT RIGHTS AND SALES RIGHTS ARE EXPRESSLY RESERVED BY SAMTEC, INC. THIS DOCUMENT SHALL NOT BE DISCLOSED, IN WHOLE OR PART, TO ANY UNAUTHORIZED PERSON OR ENTITY NOR REPRODUCED, TRANSFERRED OR INCORPORATED IN ANY OTHER PROJECT IN ANY MANNER WITHOUT THE EXPRESS WRITTEN CONSENT OF SAMTEC, INC.  
 DO NOT SCALE DRAWING  
 SHEET SCALE: 4:1

**samtec**  
 520 PARK EAST BLVD, NEW ALBANY, IN 47150  
 PHONE: 812-944-6733 FAX: 812-948-5047  
 e-Mail info@SAMTEC.com code 55322

DESCRIPTION:  
 LOW PROFILE .050 x .050 DOUBLE ROW ASM  
 DWG. NO. **CLP-1XX-XX-XXX-D-XX**  
 BY: PURVIS 01/31/1994 SHEET 2 OF 3

PACKAGING  
(SEE NOTE 4, SHEET 1)

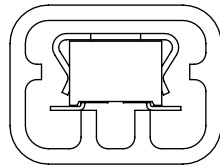

PT-CLX-002-D

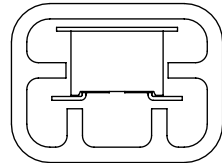

PT-CLX-001-D

TABLE 2		
OPTION	TUBE	PLUG
NONE, -A	PT-CLX001-D	TP-33
-P, -A-P	PT-CLX002-D	TP-33
-A-K, -K	PT-CLX001-D	TP-33

**PROPRIETARY NOTE**  
 THIS DOCUMENT CONTAINS CONFIDENTIAL AND PROPRIETARY INFORMATION AND ALL DESIGN, MANUFACTURING, REPRODUCTION, USE, PATENT RIGHTS AND SALES RIGHTS ARE EXPRESSLY RESERVED BY SAMTEC, INC. THIS DOCUMENT SHALL NOT BE DISCLOSED, IN WHOLE OR PART, TO ANY UNAUTHORIZED PERSON OR ENTITY NOR REPRODUCED, TRANSFERRED OR INCORPORATED IN ANY OTHER PROJECT IN ANY MANNER WITHOUT THE EXPRESS WRITTEN CONSENT OF SAMTEC, INC.

DO NOT SCALE DRAWING

SHEET SCALE: 4:1



520 PARK EAST BLVD, NEW ALBANY, IN 47150  
 PHONE: 812-944-6733 FAX: 812-948-5047  
 e-Mail info@SAMTEC.com code 55322

DESCRIPTION:  
 LOW PROFILE .050 x .050 DOUBLE ROW ASM

DWG. NO. **CLP-1XX-XX-XXX-D-XX**

BY: PURVIS 01/31/1994 SHEET 3 OF 3