

LOC		DIST		REVISIONS			
P	LTR	DESCRIPTION	DATE	DMN	APVD		
J1		REVISED PER ECO-13-013432	27AUG2013	M.T	D.Z		

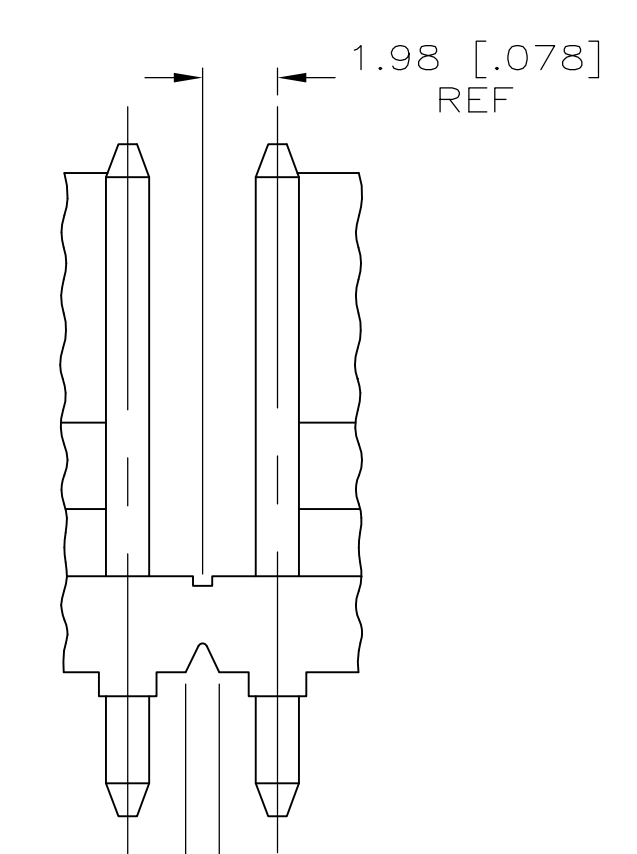

13 0.89 [.035] REF
INTERRUPTED WALL FOR POSITION SIZES 6 AND ABOVE

12

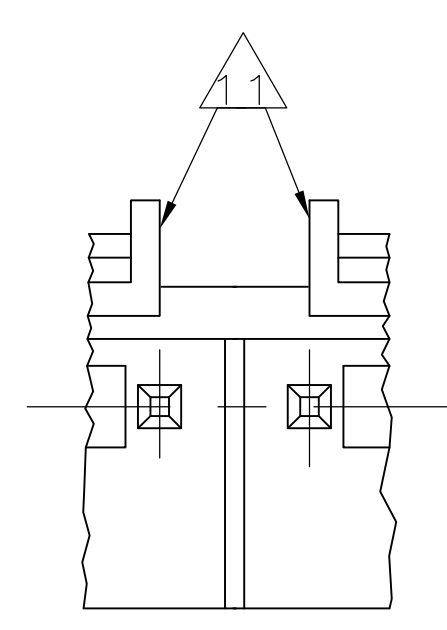
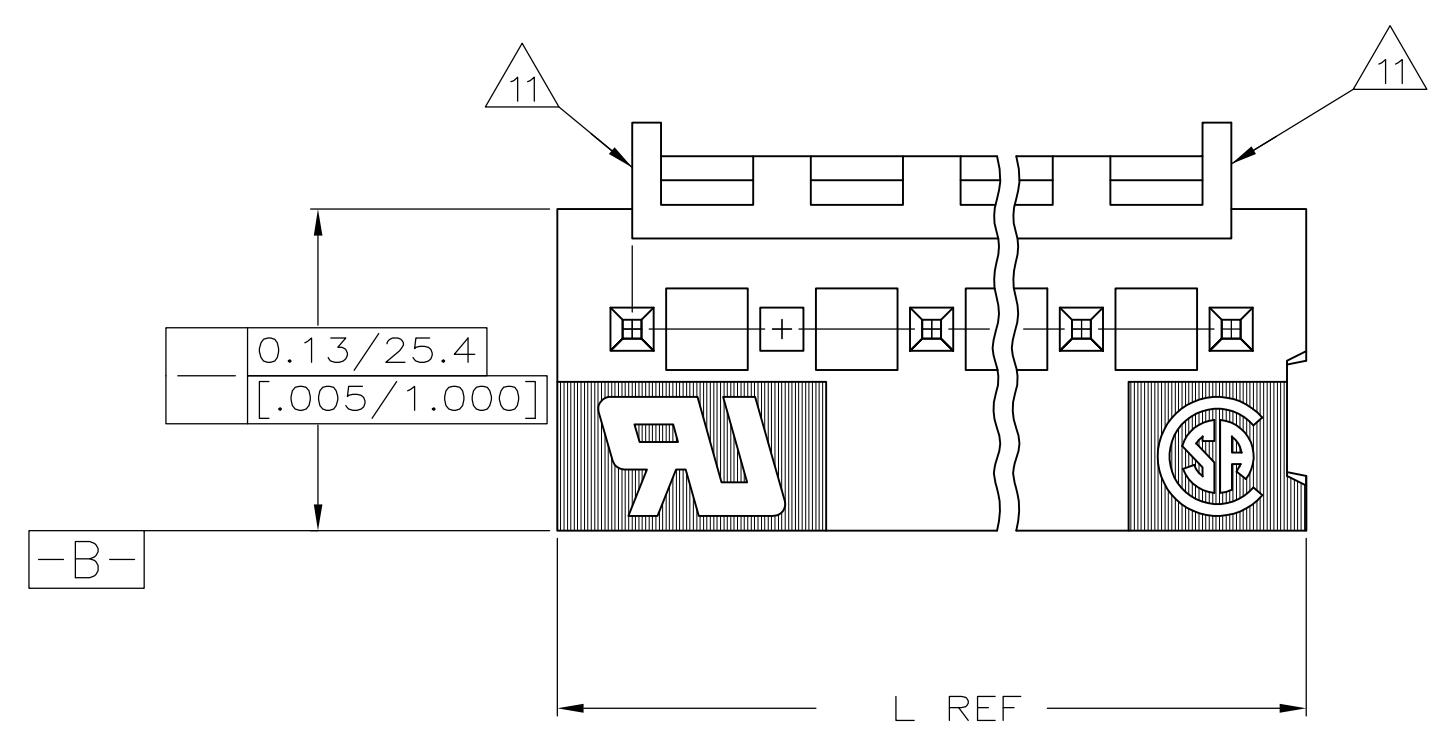
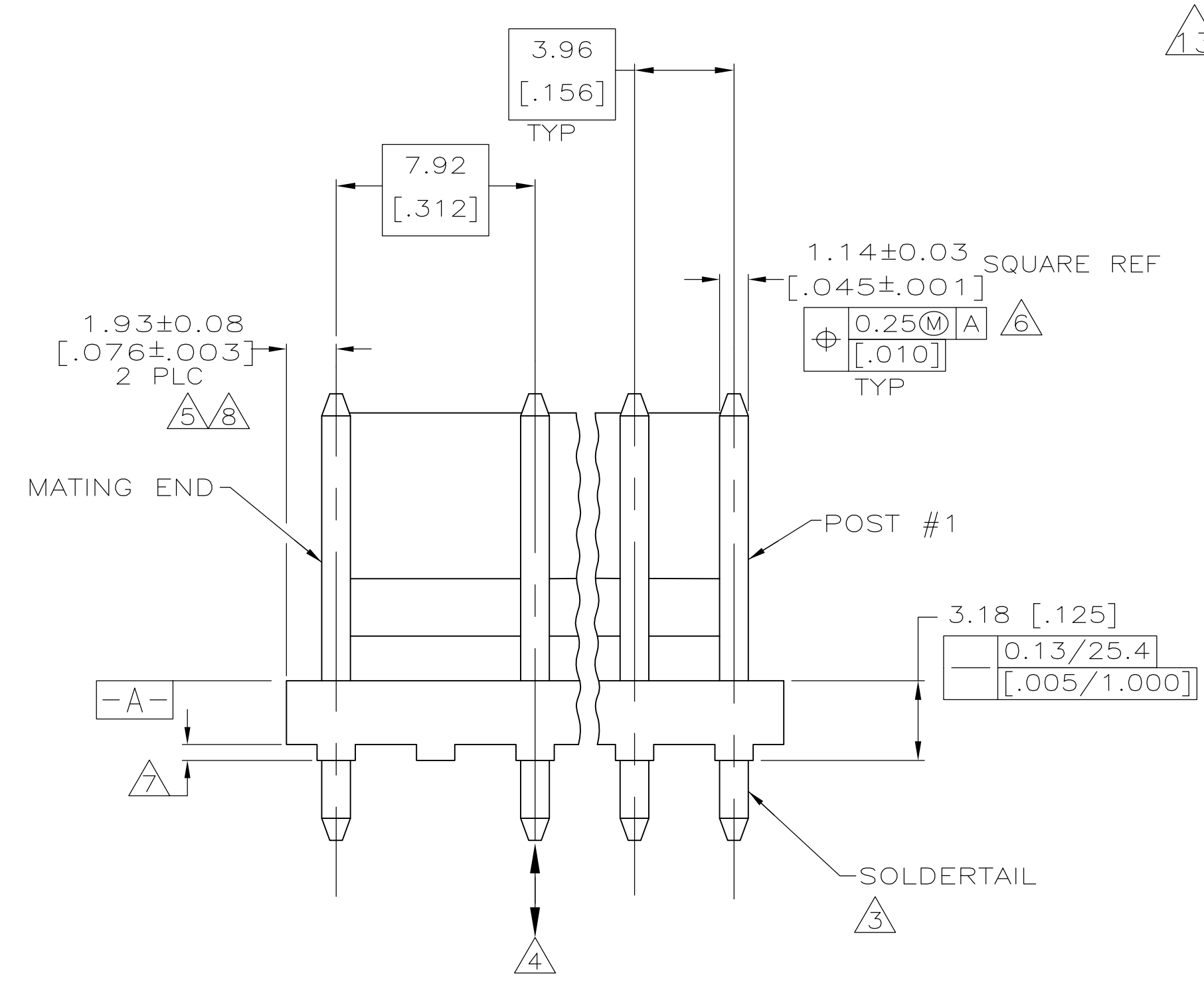

INTERRUPTED WALL FOR POSITION SIZES 6 AND ABOVE

12

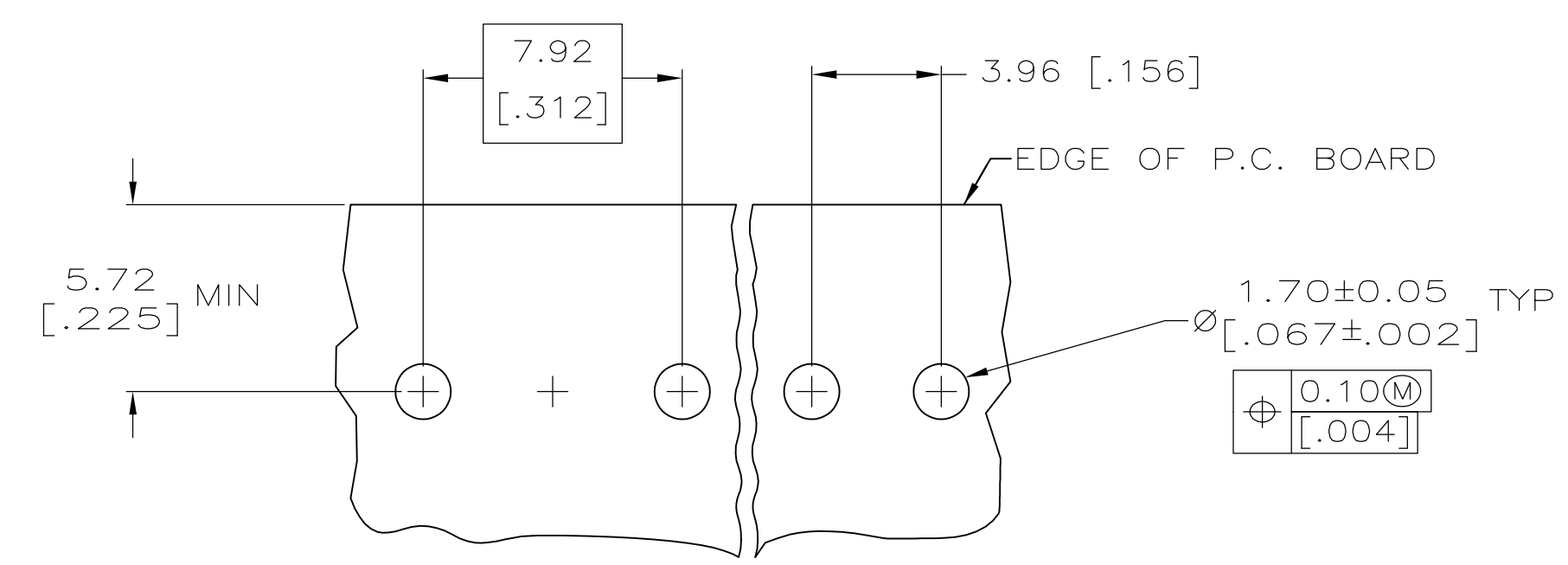
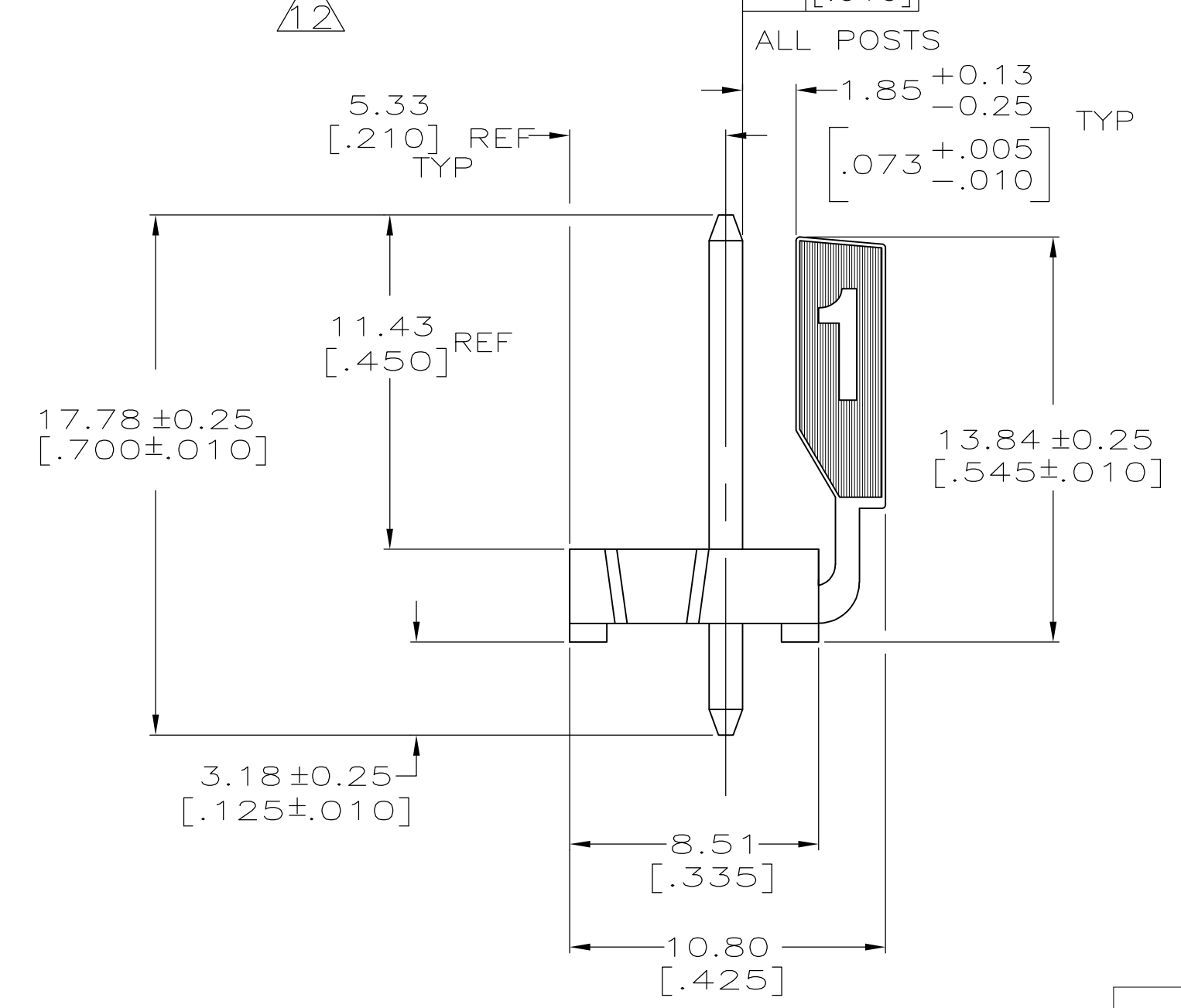

RECOMMENDED MOUNTING HOLE PATTERN FOR 1.57 [.062] THICK P.C. BOARD 9

- 1 MATERIAL
HOUSING: THERMOPLASTIC POLYESTER, GLASS FILLED, DR-48. UL94V-0.
POST: COPPER ALLOY
- 2 FINISH
HOUSING: BLACK
POST: BRIGHT TIN-LEAD (93/7) 0.00380 [.000150]-0.00880 [.000350] THICK OVER NICKEL UNDERPLATE 0.00130 [.000050] MINIMUM THICK OR MATTE TIN PLATE 0.00380 [.000150] THICK OVER NICKEL UNDERPLATE 0.00130 [.000050] MINIMUM THICK IF LEAD FREE.
- 3 POST SOLDER TAILS COMPLY WITH AMP SOLDERABILITY SPEC 109-11-2.
- 4 POST WITHSTANDS 13.34N (3 LB) MIN AXIAL FORCE IN EITHER DIRECTION WITHOUT DISLODGING.
- 5 APPLIES AT -A-.
- 6 APPLIES WHEN THE HEADER IS STRAIGHT.
- 7 PLASTIC PROJECTIONS PERMITTED IN THIS ZONE.
- 8 COORDINATE DIMENSIONS APPLIES FROM THE CENTER OF THE ACTUAL FEATURE.
- 9 SOLDER SIDE OF BOARD IS SHOWN.
- 10 DIMENSIONS IN BRACKETS ARE IN INCHES.
- 11 EDGE OF POLARIZING LOCK WALL TO BE IN LINE WITH CENTERLINE OF ADJACENT POST ±0.13 [.005].
- 12 ALL POSITION SIZES HAVE THE BACK WALL NOTCHED ON BOTH ENDS AS SHOWN. THE 2 THRU 5 POSITION SIZES HAVE SOLID BACK WALLS. POSITION SIZES 6 AND ABOVE HAVE AN INTERRUPTED BACK WALL AT VARIOUS LOCATIONS (SEE TABLE FOR INTERRUPTION(S) LOCATIONS).
- 13 NOTCH SHOWN MAY OR MAY NOT APPEAR.
- 14 OBSOLETE PART NUMBER

NOTES	LEAD FREE	BACK WALL INTERRUPTIONS BETWEEN POST	mm	[IN]	NO OF POSITIONS	PART NUMBER
	YES	3 & 4, 7 & 8	39.50	[1.555]	10	4-644992-0
	YES	4 & 5	31.57	[1.243]	8	3-644992-8
	YES	3 & 4	23.65	[.931]	6	3-644992-6
14	NO	3 & 4, 7 & 8	39.50	[1.555]	10	1-644992-0
14	NO	4 & 5	31.57	[1.243]	8	644992-8
14	NO	3 & 4	23.65	[.931]	6	644992-6

METRIC

THIS DRAWING IS A CONTROLLED DOCUMENT.

DIMENSIONS: mm [INCHES]	TOLERANCES UNLESS OTHERWISE SPECIFIED:	DIN S. HOOVER 22-OCT-2004	APPROVED D. ROSSI 22-OCT-2004
0 PLC ±	1 PLC ±	2 PLC ±	3 PLC ± 0.13 [.005]
4 PLC ±	ANGLES ±		

MATERIAL 1 FINISH 2

NAME: ASSEMBLY- MTA .156 HEADER, POLARIZED LOCK, STR .045 SQUARE POST, TIN OR TIN-LEAD PLATED, OMITTED POST #5, SPECIAL

SIZE: A1 CASE CODE: 00779 DRAWING NO: 644992 WEIGHT: RESTRICTED TO: CUSTOMER DRAWING SCALE: 5:1 SHEET: 1 OF 1 REV: J1