

DUAL-GATE UNIDIRECTIONAL OVERVOLTAGE PROTECTOR



TISP83121D Unidirectional P & N-Gate Protector

Overvoltage Protection for Dual-Voltage Ringing SLICs
 – Programmable Protection Configurations up to ± 100 V
 – Typically 5 Lines Protected by:
 Two TISP83121D + Diode Steering Networks

High Surge Current

- 150 A, 10/1000 μ s
- 250 A, 10/700 μ s
- 500 A, 8/20 μ s

Pin Compatible with the LCP3121

- 50 % more surge current
- Functional Replacement in Diode Steering Applications

Small Outline Surface Mount Package

Description

The TISP83121D is a dual-gate reverse-blocking unidirectional thyristor designed for the protection of dual-voltage ringing SLICs (Subscriber Line Interface Circuits) against overvoltages on the telephone line caused by lightning, a.c. power contact and induction.

The device chip is a four-layer NPNP silicon thyristor structure which has an electrode connection to every layer. For negative overvoltage protection the TISP83121D is used in a common anode configuration with the voltage to be limited applied to the cathode (K) terminal and the negative reference potential applied to the gate 1 (G1) terminal. For positive overvoltage protection the TISP83121D is used in a common cathode configuration with the voltage to be limited applied to the anode (A) terminal and the positive reference potential applied to the gate 2 (G2) terminal.

The TISP83121D is a unidirectional protector and to prevent reverse bias, requires the use of a series diode between the protected line conductor and the protector. Further, the gate reference supply voltage requires an appropriately poled series diode to prevent the supply from being shorted when the TISP83121D crowbars.

Under low level power cross conditions the TISP83121D gate current will charge the gate reference supply. If the reference supply cannot absorb the charging current its potential will increase, possibly to damaging levels. To avoid excessive voltage levels a clamp (zener or avalanche breakdown diode) may be added in shunt with the supply. Alternatively, a grounded collector emitter-follower may be used to reduce the charging current by the transistor's H_{FE} value.

This monolithic protection device is made with an ion-implanted epitaxial-planar technology to give a consistent protection performance and be virtually transparent to the system in normal operation.

How To Order

Device	Package	Carrier	Order As
TISP83121	D (8-pin Small-Outline)	R (Embossed Tape Reeled)	TISP83121DR-S

8-SOIC Package (Top View)

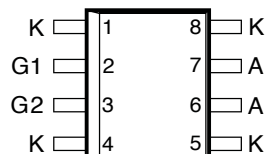

MD6XAYB

For operation at the rated current values connect pins 1, 4, 5 and 8 together.

Device Symbol

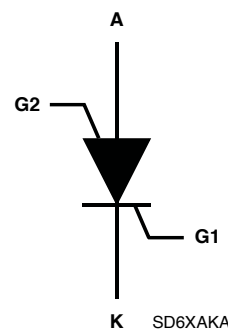

 UL Recognized Component



WARNING Cancer and Reproductive Harm
www.P65Warnings.ca.gov

FEBRUARY 1999 – REVISED JULY 2008

*RoHS Directive 2002/95/EC Jan. 27, 2003 including Annex.

Specifications are subject to change without notice. Users should verify actual device performance in their specific applications. The products described herein and this document are subject to specific legal disclaimers as set forth on the last page of this document, and at www.bourns.com/docs/legal/disclaimer.pdf.

TISP83121D Unidirectional P & N-Gate Protector

BOURNS®

Absolute Maximum Ratings

Rating	Symbol	Value	Unit
Repetitive peak off-state voltage, 0 °C to 70 °C	V_{DRM}	100	V
Non-repetitive peak on-state pulse current (see Notes 1 and 2) 10/1000 μ s (GR-1089-CORE, open-circuit voltage wave shape 10/1000 μ s) 5/310 μ s (CCITT K20/21, open-circuit voltage wave shape 7 kV, 10/700 μ s) 8/20 μ s (ANSI C62.41, open-circuit voltage wave shape 1.2/50 μ s)	I_{TSP}	150 250 500	A
Non-repetitive peak on-state current, 50 Hz, halfwave rectified sinewave, (see Notes 1 and 2) 100 ms 1 s 900 s	I_{TSM}	22 8 3	A
Junction temperature	T_J	-40 to +150	°C
Storage temperature range	T_{stg}	-65 to +150	°C

- NOTES: 1. Initially the protector must be in thermal equilibrium with 0 °C < T_J < 70 °C. The surge may be repeated after the device returns to its initial conditions. For operation at the rated current value, pins 1, 4, 5 and 8 must be connected together.
2. Above 70 °C, derate linearly to zero at 150 °C lead temperature.

Electrical Characteristics, $T_J = 25$ °C (Unless Otherwise Noted)

Parameter	Test Conditions	Min	Typ	Max	Unit
I_D	Off-state current $V_d = 70$ V, $I_G = 0$			1	μ A
I_{DRM}	Repetitive peak off-state current $V_d = V_{DRM} = 100$ V, $I_G = 0$, 0 °C to 70 °C			10	μ A
I_H	Holding current $I_T = 1$ A, $di/dt = -1$ A/ms $T_J = 0$ to 70 °C $T_J = 25$ °C $T_J = 70$ °C	90 60		300	mA
I_R	Reverse current $V_R = 0.3$ V			1	mA
I_{G1T}	Gate G1 trigger current $I_T = +1$ A, $t_{p(g)} = 20$ μ s			+200	mA
I_{G2T}	Gate G2 trigger current $I_T = +1$ A, $t_{p(g)} = 20$ μ s			-180	mA
V_{G1T}	G1-K trigger voltage $I_T = +1$ A, $t_{p(g)} = 20$ μ s			+1.8	V
V_{G2T}	G2-A trigger voltage $I_T = +1$ A, $t_{p(g)} = 20$ μ s			-1.8	V
C_{AK}	Anode-cathode off-state capacitance $f = 1$ MHz, $V_d = 1$ V rms, $V_D = 5$ V, $I_G = 0$ (see Note 3)			100	pF

- NOTE 3: These capacitance measurements employ a three terminal capacitance bridge incorporating a guard circuit. The unmeasured device terminals are a.c. connected to the guard terminal of the bridge.

Thermal Characteristics

Parameter	Test Conditions	Min	Typ	Max	Unit
$R_{\theta JA}$	Junction to free air thermal resistance $T_A = 25$ °C, EIA/JESD51-3 PCB, EIA/JESD51-2 environment, $I_T = I_{TSM(900)}$			105	°C/W

FEBRUARY 1999 – REVISED JULY 2008

Specifications are subject to change without notice.

Users should verify actual device performance in their specific applications.

The products described herein and this document are subject to specific legal disclaimers as set forth on the last page of this document, and at www.bourns.com/docs/legal/disclaimer.pdf.

Parameter Measurement Information

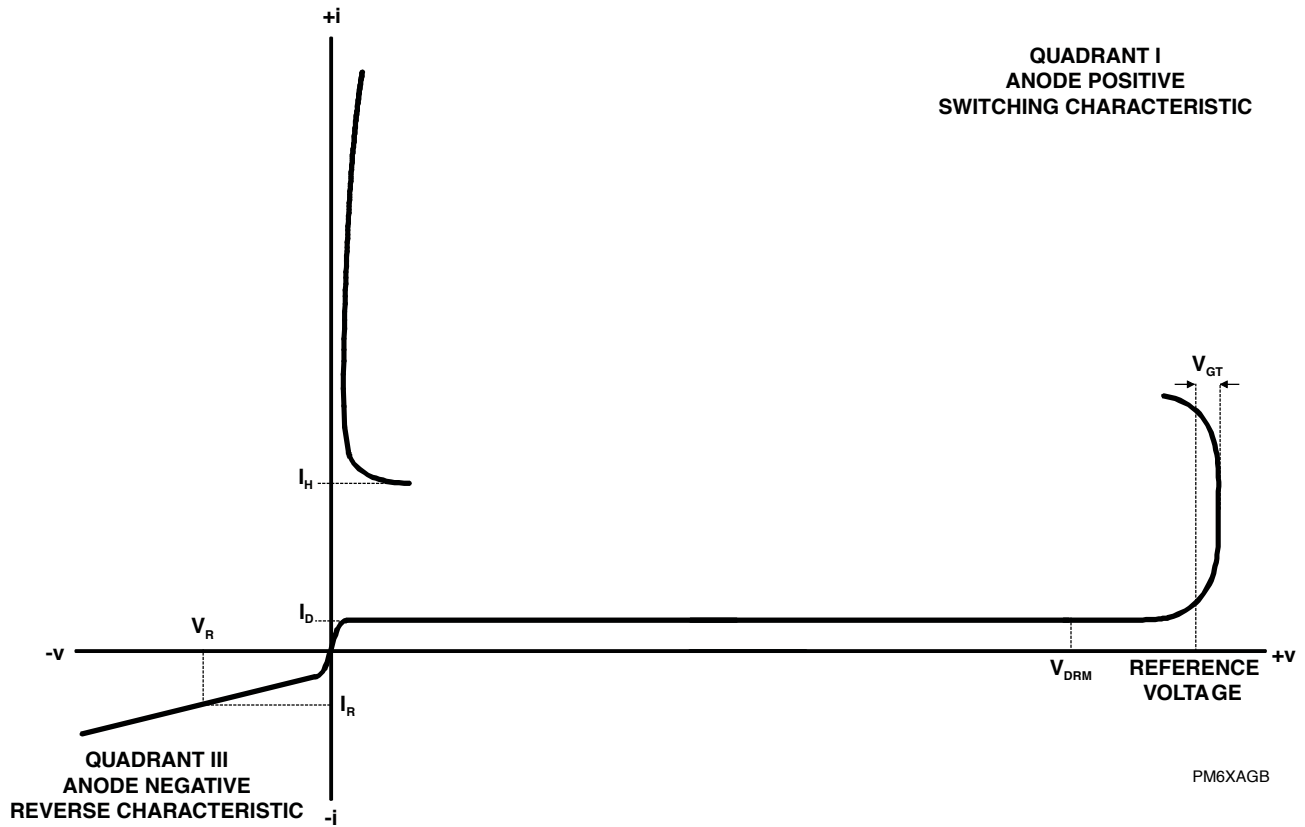

Figure 1. Voltage-Current Characteristic

APPLICATIONS INFORMATION

Multiple Line Overvoltage Protection

Figure 2 shows two TISP83121D devices protecting many lines. Line conductor positive overvoltage protection is given by the steering diode array connected to the anode of the upper TISP83121D and the TISP83121D itself. The TISP83121D gate reference voltage is the positive battery supply, $+V_{BAT}$. The initial limiting voltage will be the sum of the voltages of the battery, the forward biased conductor diode, the gate trigger of the TISP83121D and the forward biased reference voltage blocking diode. Typically the conductor voltage will be initially limited at 2.5 V above the $+V_{BAT}$ value.

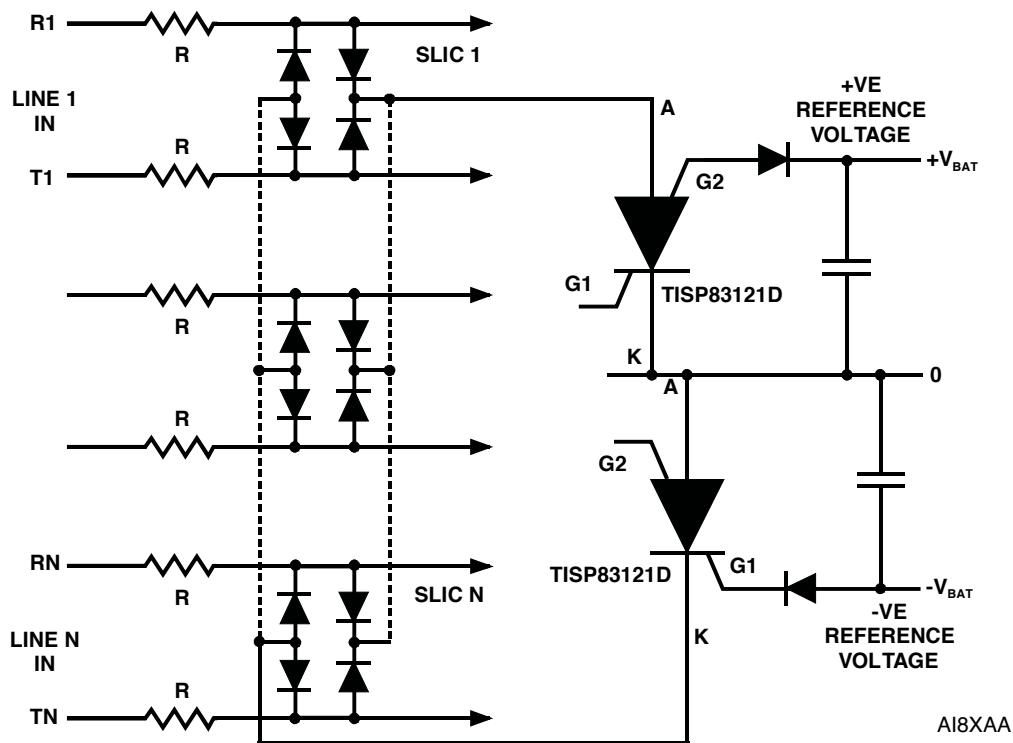

Figure 2. N Line Positive and Negative Overvoltage Protection

Line conductor negative overvoltage protection is given by the diode steering array connected to the cathode of the lower TISP83121D and the TISP83121D itself. The TISP83121D gate reference voltage is the negative battery supply, $-V_{BAT}$. The initial limiting voltage will be the sum of the voltages of the battery, the forward biased conductor diode, the gate trigger of the TISP83121D and the forward biased reference voltage blocking diode. Typically the conductor voltage will be initially limited at 2.5 V below the $-V_{BAT}$ value.

When a TISP83121D crowbars and grounds all conductors of the appropriate polarity, the device current will be the sum of all the SLIC output currents. This will usually exceed the TISP83121D holding current. To switch off the TISP83121D and restore normal operation, the grounded condition of the SLIC output must be detected and the SLIC outputs turned off.

The 150 A rating of the TISP83121D allows a large number of lines to be protected against currents caused by lightning. For example, if a recommendation K.20 10/700 generator was connected to all lines, together with 350 V primary protection and a series conductor resistance (R) of 25 Ω , the maximum conductor current before the primary protection operated would be $350/25 = 14$ A or 28 A per line. For a total return current of about 150 A the number of lines would be $150/28 = 5$. At this current level, $5 \times 28 = 140$ A, the generator voltage would be $140((25+25)/10+15) = 2800$ V. Another limitation is long term power cross. The long term power cross capability of the TISP83121D is 3 A peak or 2.1 A rms. If the line conductor overcurrent protection was given by a PTC thermistor which tripped at 0.2 A, the maximum number of conductors becomes $2.1/0.2 = 10$ or 5 lines.

Battery Supply Impedance

In many designs, the battery supply voltages are generated by switching mode power supplies. This type of power supply cannot be charged like a battery. Feeding a charging current to a switching mode power supply will usually cause the supply to stop switching and the voltage to rise. The gate current of the TISP83121D is a charging current for the supply. To avoid the supply voltage from rising and damaging the connected SLICs, an avalanche diode voltage clamp can be connected across the supply (Figure 3. (A)).

Another approach is to reduce the gate charging current for the supply by a transistor buffer (Figure 3. (B)). If the transistor gain was 50, a 200 mA gate current would be reduced to a supply charging current of $200/50 = 4$ mA. In both cases, the dissipation in the control devices can be substantial and power capability needs to be taken into account in device selection.

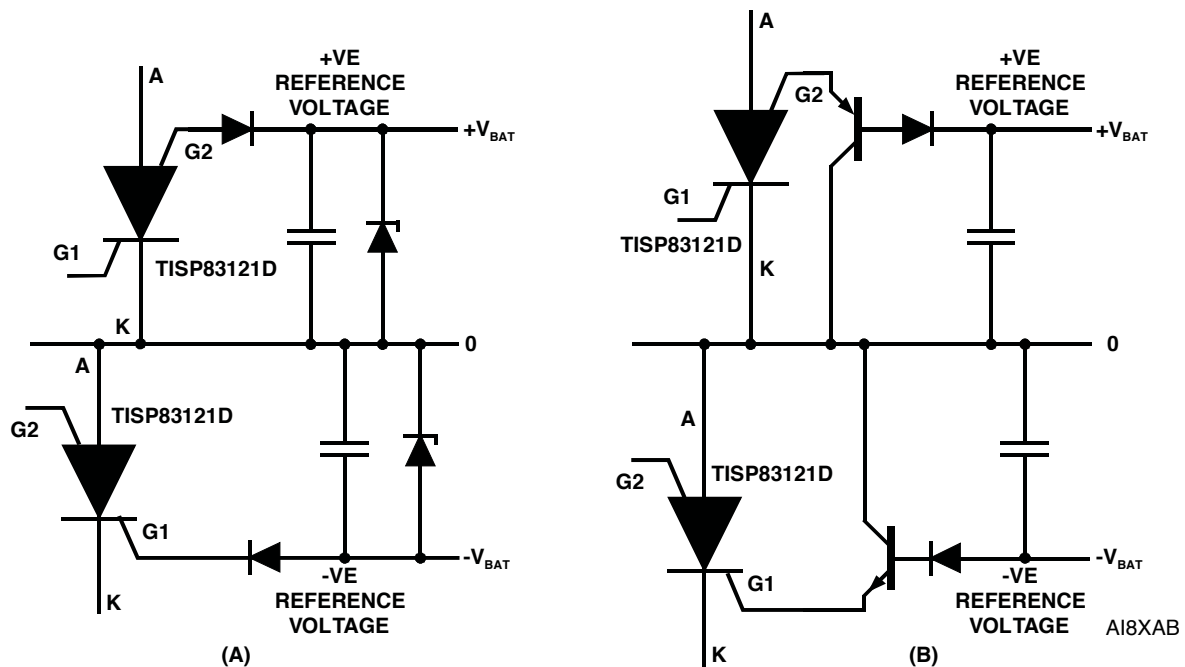

Figure 3. Reference Voltage Control by (A) Breakdown Diodes or (B) by Transistor Buffers

"TISP" is a trademark of Bourns, Ltd., a Bourns Company, and is Registered in U.S. Patent and Trademark Office. "Bourns" is a registered trademark of Bourns, Inc. in the U.S. and other countries.

FEBRUARY 1999 – REVISED JULY 2008

Specifications are subject to change without notice.

Users should verify actual device performance in their specific applications.

The products described herein and this document are subject to specific legal disclaimers as set forth on the last page of this document, and at www.bourns.com/docs/legal/disclaimer.pdf.

This legal disclaimer applies to purchasers and users of Bourns® products manufactured by or on behalf of Bourns, Inc. and its affiliates (collectively, “Bourns”).

Unless otherwise expressly indicated in writing, Bourns® products and data sheets relating thereto are subject to change without notice. Users should check for and obtain the latest relevant information and verify that such information is current and complete before placing orders for Bourns® products.

The characteristics and parameters of a Bourns® product set forth in its data sheet are based on laboratory conditions, and statements regarding the suitability of products for certain types of applications are based on Bourns’ knowledge of typical requirements in generic applications. The characteristics and parameters of a Bourns® product in a user application may vary from the data sheet characteristics and parameters due to (i) the combination of the Bourns® product with other components in the user’s application, or (ii) the environment of the user application itself. The characteristics and parameters of a Bourns® product also can and do vary in different applications and actual performance may vary over time. Users should always verify the actual performance of the Bourns® product in their specific devices and applications, and make their own independent judgments regarding the amount of additional test margin to design into their device or application to compensate for differences between laboratory and real world conditions.

Unless Bourns has explicitly designated an individual Bourns® product as meeting the requirements of a particular industry standard (e.g., ISO/TS 16949) or a particular qualification (e.g., UL listed or recognized), Bourns is not responsible for any failure of an individual Bourns® product to meet the requirements of such industry standard or particular qualification. Users of Bourns® products are responsible for ensuring compliance with safety-related requirements and standards applicable to their devices or applications.

Bourns® products are not recommended, authorized or intended for use in nuclear, lifesaving, life-critical or life-sustaining applications, nor in any other applications where failure or malfunction may result in personal injury, death, or severe property or environmental damage. Unless expressly and specifically approved in writing by two authorized Bourns representatives on a case-by-case basis, use of any Bourns® products in such unauthorized applications might not be safe and thus is at the user’s sole risk. Life-critical applications include devices identified by the U.S. Food and Drug Administration as Class III devices and generally equivalent classifications outside of the United States.

Bourns expressly identifies those Bourns® standard products that are suitable for use in automotive applications on such products’ data sheets in the section entitled “Applications.” Unless expressly and specifically approved in writing by two authorized Bourns representatives on a case-by-case basis, use of any other Bourns® standard products in an automotive application might not be safe and thus is not recommended, authorized or intended and is at the user’s sole risk. If Bourns expressly identifies a sub-category of automotive application in the data sheet for its standard products (such as infotainment or lighting), such identification means that Bourns has reviewed its standard product and has determined that if such Bourns® standard product is considered for potential use in automotive applications, it should only be used in such sub-category of automotive applications. Any reference to Bourns® standard product in the data sheet as compliant with the AEC-Q standard or “automotive grade” does not by itself mean that Bourns has approved such product for use in an automotive application.

Bourns® standard products are not tested to comply with United States Federal Aviation Administration standards generally or any other generally equivalent governmental organization standard applicable to products designed or manufactured for use in aircraft or space applications. Bourns expressly identifies Bourns® standard products that are suitable for use in aircraft or space applications on such products’ data sheets in the section entitled “Applications.” Unless expressly and specifically approved in writing by two authorized Bourns representatives on a case-by-case basis, use of any other Bourns® standard product in an aircraft or space application might not be safe and thus is not recommended, authorized or intended and is at the user’s sole risk.

The use and level of testing applicable to Bourns® custom products shall be negotiated on a case-by-case basis by Bourns and the user for which such Bourns® custom products are specially designed. Absent a written agreement between Bourns and the user regarding the use and level of such testing, the above provisions applicable to Bourns® standard products shall also apply to such Bourns® custom products.

Users shall not sell, transfer, export or re-export any Bourns® products or technology for use in activities which involve the design, development, production, use or stockpiling of nuclear, chemical or biological weapons or missiles, nor shall they use Bourns® products or technology in any facility which engages in activities relating to such devices. The foregoing restrictions apply to all uses and applications that violate national or international prohibitions, including embargos or international regulations. Further, Bourns® products and Bourns technology and technical data may not under any circumstance be exported or re-exported to countries subject to international sanctions or embargoes. Bourns® products may not, without prior authorization from Bourns and/or the U.S. Government, be resold, transferred, or re-exported to any party not eligible to receive U.S. commodities, software, and technical data.

To the maximum extent permitted by applicable law, Bourns disclaims (i) any and all liability for special, punitive, consequential, incidental or indirect damages or lost revenues or lost profits, and (ii) any and all implied warranties, including implied warranties of fitness for particular purpose, non-infringement and merchantability.

For your convenience, copies of this Legal Disclaimer Notice with German, Spanish, Japanese, Traditional Chinese and Simplified Chinese bilingual versions are available at:

Web Page: <http://www.bourns.com/legal/disclaimers-terms-and-policies>

PDF: <http://www.bourns.com/docs/Legal/disclaimer.pdf>