

UMA

5mmL, Standard, For General Purposes



Anti-Solvent Feature

- Standard series with 5mm height.
- Compliant to the RoHS directive (2011/65/EU).

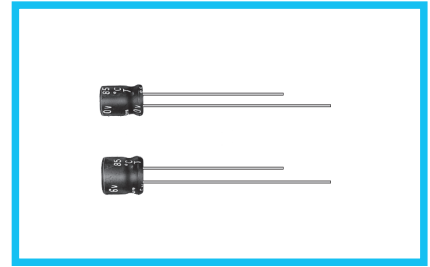
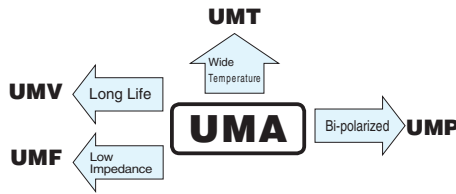

Specifications

Item	Performance Characteristics																										
Category Temperature Range	-40 to +85°C																										
Rated Voltage Range	4 to 50V																										
Rated Capacitance Range	1 to 470μF																										
Rated Capacitance Tolerance	±20% at 120Hz, 20°C																										
Leakage Current	After 2 minutes' application of rated voltage at 20°C, leakage current is not more than 0.01CV or 3(μA), whichever is greater.																										
Tangent of loss angle (tan δ)	Measurement frequency : 120Hz at 20°C																										
	<table border="1"> <tr> <td>Rated voltage (V)</td> <td>4</td> <td>6.3</td> <td>10</td> <td>16</td> <td>25</td> <td>35</td> <td>50</td> <td rowspan="2">Figures in () are for UMR.</td> </tr> <tr> <td>tan δ (MAX.)</td> <td>0.35</td> <td>0.24 (0.30)</td> <td>0.20 (0.24)</td> <td>0.16 (0.20)</td> <td>0.14 (0.18)</td> <td>0.12 (0.16)</td> <td>0.10 (0.13)</td> </tr> </table>	Rated voltage (V)	4	6.3	10	16	25	35	50	Figures in () are for UMR.	tan δ (MAX.)	0.35	0.24 (0.30)	0.20 (0.24)	0.16 (0.20)	0.14 (0.18)	0.12 (0.16)	0.10 (0.13)									
Rated voltage (V)	4	6.3	10	16	25	35	50	Figures in () are for UMR.																			
tan δ (MAX.)	0.35	0.24 (0.30)	0.20 (0.24)	0.16 (0.20)	0.14 (0.18)	0.12 (0.16)	0.10 (0.13)																				
Stability at Low Temperature	Measurement frequency : 120Hz																										
	<table border="1"> <tr> <td colspan="2">Rated voltage (V)</td> <td>4</td> <td>6.3</td> <td>10</td> <td>16</td> <td>25</td> <td>35</td> <td>50</td> </tr> <tr> <td>Impedance ratio</td> <td>Z-25°C / Z+20°C</td> <td>7</td> <td>4</td> <td>3</td> <td>2</td> <td>2</td> <td>2</td> <td>2</td> </tr> <tr> <td>ZT / Z20 (MAX.)</td> <td>Z-40°C / Z+20°C</td> <td>15</td> <td>8</td> <td>6</td> <td>4</td> <td>4</td> <td>3</td> <td>3</td> </tr> </table>	Rated voltage (V)		4	6.3	10	16	25	35	50	Impedance ratio	Z-25°C / Z+20°C	7	4	3	2	2	2	2	ZT / Z20 (MAX.)	Z-40°C / Z+20°C	15	8	6	4	4	3
Rated voltage (V)		4	6.3	10	16	25	35	50																			
Impedance ratio	Z-25°C / Z+20°C	7	4	3	2	2	2	2																			
ZT / Z20 (MAX.)	Z-40°C / Z+20°C	15	8	6	4	4	3	3																			
Endurance	<p>The specifications listed at right shall be met when the capacitors are restored to 20°C after the rated voltage is applied for 2000 hours at 85°C.</p> <table border="1"> <tr> <td>Capacitance change</td> <td>Within ±20% of the initial capacitance value (UMR & φ3 product : Within ±25%)</td> </tr> <tr> <td>tan δ</td> <td>200% or less than the initial specified value</td> </tr> <tr> <td>Leakage current</td> <td>Less than or equal to the initial specified value</td> </tr> </table>	Capacitance change	Within ±20% of the initial capacitance value (UMR & φ3 product : Within ±25%)	tan δ	200% or less than the initial specified value	Leakage current	Less than or equal to the initial specified value																				
Capacitance change	Within ±20% of the initial capacitance value (UMR & φ3 product : Within ±25%)																										
tan δ	200% or less than the initial specified value																										
Leakage current	Less than or equal to the initial specified value																										
Shelf Life	After storing the capacitors under no load at 85°C for 1000 hours and then performing voltage treatment based on JIS C 5101-4 clause 4.1 at 20°C, they shall meet the specified values for the endurance characteristics listed above.																										
Marking	Printed with white color letter on black sleeve.																										

Radial Lead Type

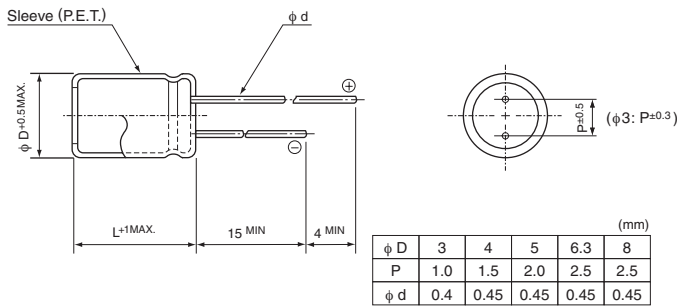

● Please refer to page 20 about the end seal configuration.

Type numbering system (Example : 25V 10μF)

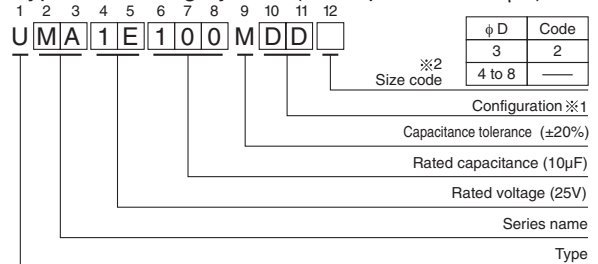

※ 1 Configuration

φ D	Pb-free leadwire Pb-free PET sleeve
3	CD
4 to 8	DD

※ 2 In case at φ 3 units, put [2] as size code.

Dimensions

Cap. (μF)	Code	4		6.3		10		16		25		35		50	
		0G		0J		1A		1C		1E		1V		1H	
1	010														4×5(3×5) 8.4(8.0)
2.2	2R2														● 4×5 13(10)
3.3	3R3														4×5 17
4.7	4R7														5×5 20
10	100			3×5 15											● 4×5 23(18) 5×5 27 6.3×5 29 6.3×5 33
22	220	3×5 19		● 4×5 28(21)		5×5 33		5×5 37		6.3×5 42		6.3×5 46		□ 8×5 52(48)	8×5 71
33	330	4×5 28		5×5 37		5×5 41		○ 6.3×5 49(43)		6.3×5 52		□ 8×5 62(52)		8×5 71	
47	470	4×5 33		5×5 45		○ 6.3×5 52(43)		6.3×5 58		□ 8×5 70(62)		8×5 80			
100	101	5×5 56		○ 6.3×5 70(68)		□ 8×5 80(76)		□ 8×5 92(86)		8×5 110					
220	221	6.3×5 96		□ 8×5 110(90)		8×5 135									
330	331	8×5 145		8×5 170											
470	471	8×5 185													

Size φ3 × 5 is available for capacitors marked. *●*/ Size φ5 × 5 is available for capacitors marked. *b*
Size φ6.3 × 5 is available for capacitors marked. *□* In such a case, [M][R] will be put at 2nd and 3rd digit of type numbering system.

Rated ripple current (mA rms) at 85°C 120Hz
() = φ3 units and UMR.

Frequency coefficient of rated ripple current

Frequency	50 Hz	120 Hz	300 Hz	1 kHz	10kHz or more
Coefficient	0.70	1.00	1.17	1.36	1.50

Please refer to page 20, 21, 22 about the formed or taped product spec.
Please refer to page 4 for the minimum order quantity.

Mouser Electronics

Authorized Distributor

Click to View Pricing, Inventory, Delivery & Lifecycle Information:

Nichicon:

[UMR1A470MDD](#) [UMR1C100MCD2](#) [UMR1C101MDD](#) [UMR1V330MDD](#) [UMR1V3R3MCD2](#) [UMR0J221MDD](#)
[UMR1A101MDD](#) [UMR1H220MDD](#) [UMR1H2R2MCD2](#) [UMR0J101MDD](#) [UMR0J220MCD2](#) [UMR1E4R7MCD2](#)
[UMR1C330MDD](#) [UMR1E470MDD](#) [UMR1E470MDD1TE](#) [UMA1V4R7MDD1TP](#) [UMR1A101MDD1TE](#)
[UMA1H4R7MDD1TE](#) [UMR1A101MDD1TP](#) [UMA1E470MDD1TE](#) [UMA1V4R7MDD1TE](#) [UMA1H010MDD1TE](#)
[UMA1H3R3MDD1TE](#)