

OPERATING CHARACTERISTICS AT 25°C AMBIENT

DIALIGHT PART NUMBER	COLOR	LUMINOUS INTENSITY (mcd) @ I <sub>F</sub> = 5 mA			FORWARD VOLTAGE (V) @ I <sub>F</sub> = 5 mA			REVERSE CURRENT (μA)	CHROMATICITY COORDINATES (nm) @ I <sub>F</sub> = 5 mA		VIEWING ANGLE (DEG)
		MIN	TYP	MAX	MIN	TYP	MAX	MAX	x (TYP)	y (TYP)	TYP
597-6901-602F, -607F	WHITE	28.0		112.0	2.7		3.15	10	.304	.301	70

ABSOLUTE MAXIMUM RATINGS AT 25°C AMBIENT	VALUE	UNITS
POWER DISSIPATION	70	mW
DC FORWARD CURRENT	20	mA
PEAK FORWARD CURRENT (1/10 DUTY CYCLE, 0.1 ms PULSE WIDTH)	100	mA
DERATE LINEARLY FROM 25°C	0.25	mA/°C
REVERSE VOLTAGE	5	V
STORAGE TEMPERATURE	-55 TO +105	°C
OPERATING TEMPERATURE	-20 TO +80	°C
SOLDERING TEMPERATURE, FOR 5 SEC	260	°C

LUMINOUS INTENSITY mcd @ I <sub>F</sub> =5mA		
BIN	MIN	MAX
N	28.0	45.0
P	45.0	71.0
Q	71.0	112.0

TOLERANCE ON EACH INTENSITY BIN IS ±15%

COLOR BIN LIMITS @ I <sub>F</sub> =5mA					
BIN CODE	CIE 1931 CHROMATICITY COORDINATES	x	y	z	u
S1	x	0.274	0.274	0.294	0.294
	y	0.226	0.258	0.286	0.254
S2	x	0.274	0.274	0.294	0.294
	y	0.258	0.291	0.319	0.286
S3	x	0.294	0.294	0.314	0.314
	y	0.254	0.286	0.315	0.282
S4	x	0.294	0.294	0.314	0.314
	y	0.286	0.319	0.347	0.315
S5	x	0.314	0.314	0.334	0.334
	y	0.282	0.315	0.343	0.311
S6	x	0.314	0.314	0.334	0.334
	y	0.315	0.347	0.376	0.343

TOLERANCE ON EACH CHROMATICITY COORDINATE IS ±0.01

RECOMMENDED SOLDER PAD LAYOUT

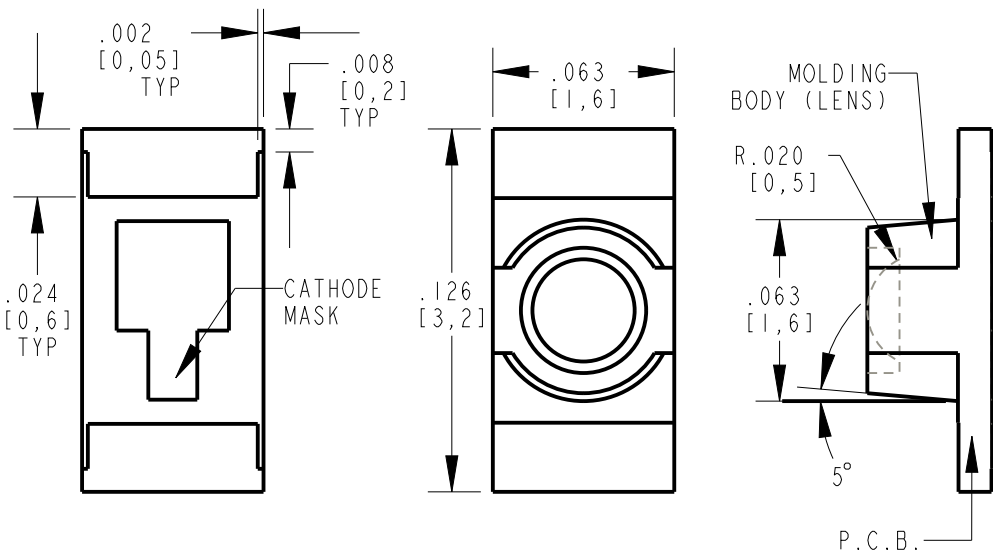
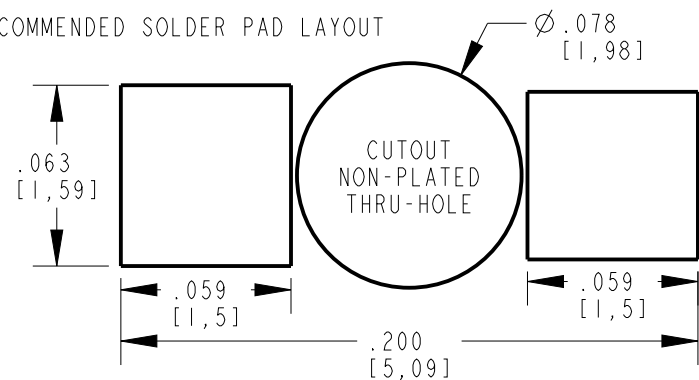

POLARITY

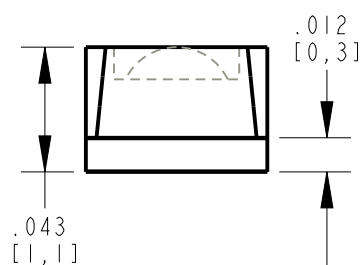

**ATTENTION:**  
OBSERVE PRECAUTIONS FOR  
HANDLING ELECTROSTATIC  
SENSITIVE DEVICES

**RoHS COMPLIANT 597-6901-60XF**

Part Numbers with the "F" suffix ending are RoHS Compliant.  
For example: 597-6901-607F  
Packaging is marked with "RoHS Compliant" label or equivalent markings. These parts can be used with RoHS reflow profile.  
Parts can be wave soldered, dip soldered or hand soldered using typical lead-free soldering process with max 260°C temp. for 5 sec.

NOTES:

1. LENS: YELLOW
2. LED CHIP: InGaN
3. LEADS ARE GOLD (Au) PLATED FINISH.
4. PACKAGING: -602F SUFFIX MEANS 20 PCS SAMPLE STRIP  
-607F SUFFIX MEANS 3000 PARTS/REEL, 7 INCH (180mm) DIA. REEL.
5. THIS ASSEMBLY CONTAINS ELECTROSTATIC DISCHARGE SENSITIVE DEVICES (ESDS). MAINTAIN ALL PRECAUTIONARY MEASURES DURING ASSEMBLY, HANDLING, AND STORAGE IN ACCORDANCE WITH IPC-A-610.
6. MOISTURE SENSITIVITY LEVEL 3.
7. TAPE AND REEL LEDS MAY REQUIRE RE-TAPING AFTER TWELVE MONTHS.

REV	ECN NO	REVISIONS	DRN	CKD	APP	DATE
A		NEW RELEASE	WFB	JTD	NO	06-08-12

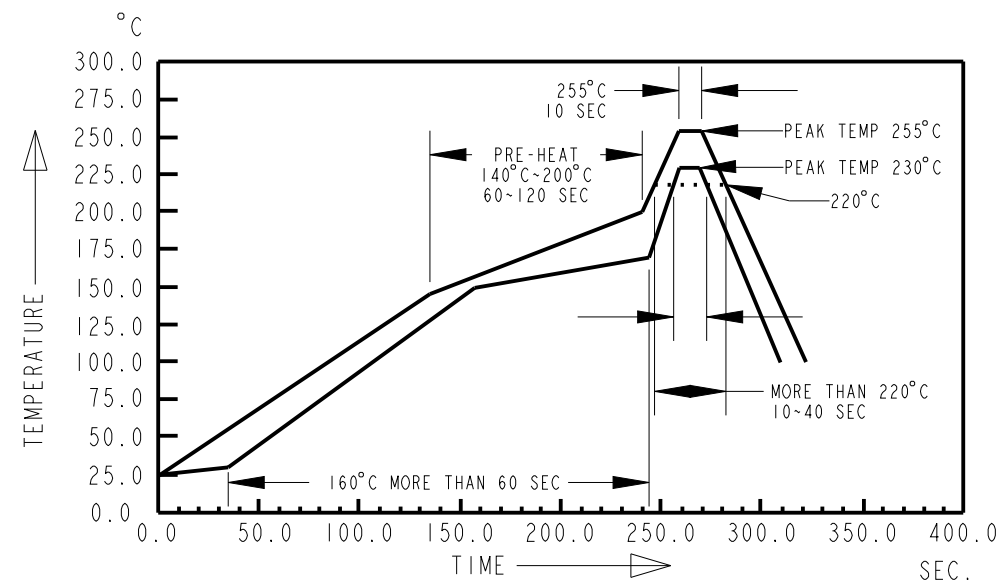
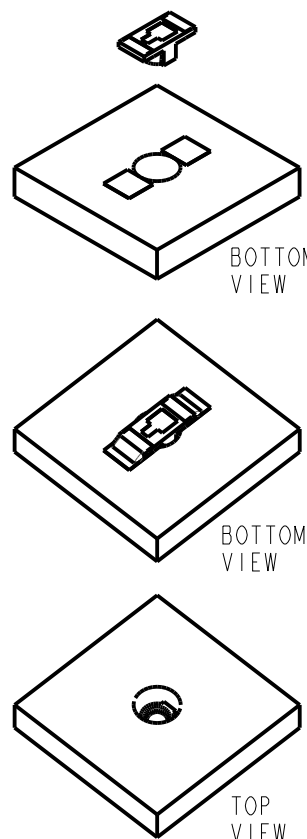

RECOMMENDED RoHS SOLDER PROFILE

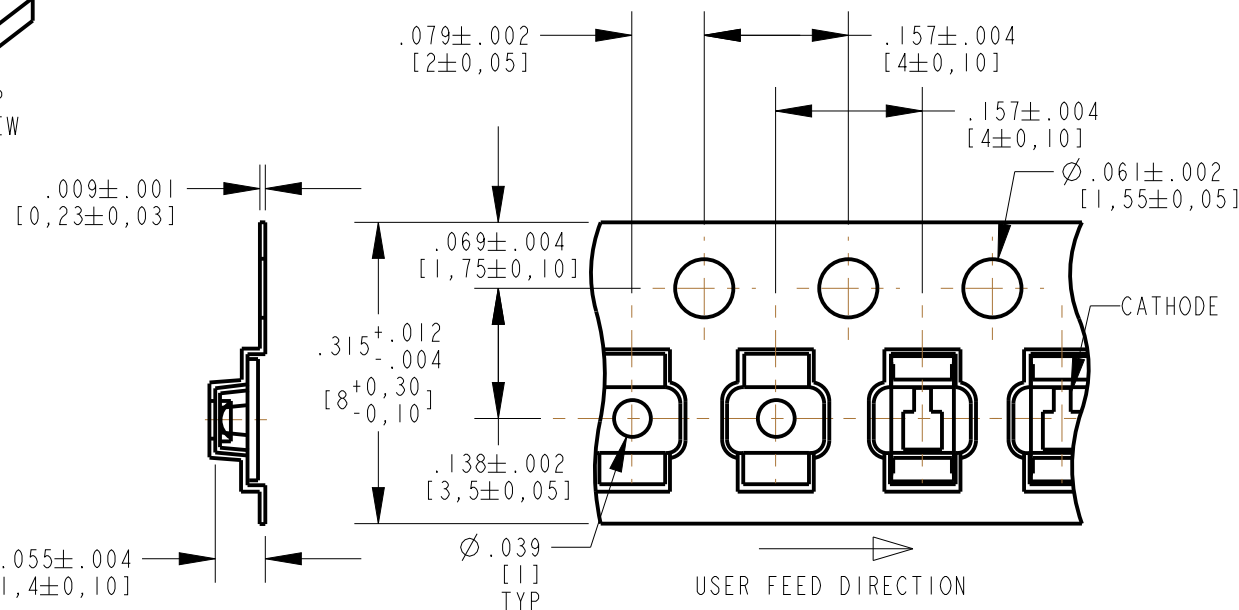

PACKAGE DIMENSIONS OF TAPE AND REEL

THIS DRAWING AND THE CONTENTS HEREIN ARE CONFIDENTIAL AND THE SOLE PROPERTY OF DIALIGHT. REPRODUCTION OF THIS DRAWING OR CONSTRUCTION OF ANY PARTS WITHIN THIS DRAWING ARE FORBIDDEN WITHOUT THE WRITTEN CONSENT OF DIALIGHT.

SCALE: DRAWING SCALE ALL DIM'S IN: INCHES (MM)	DRAWING NUMBER C-17970	REV A
TOLERANCES: UNLESS OTHERWISE SPECIFIED	TITLE 3.2mm x 1.6mm x 1.1mm REVERSE MOUNT WHITE LED; RoHS COMPLIANT	
FRACTIONS: ±1/64 DECIMALS (.XX): ±.01 DECIMALS (.XXX): ±.005 DECIMALS (.XXXX): ±.0005 ANGLES: ±1°	MATERIAL	
FINISH:	Dialight 1501 ROUTE 34 SOUTH FARMINGDALE, NJ 07727	
FSCM 83330	SHEET 1 OF 1 FAMILY TABLE:	

# Mouser Electronics

Authorized Distributor

Click to View Pricing, Inventory, Delivery & Lifecycle Information:

Dialight:

[597-6901-602F](#) [597-6901-607F](#)