

# NL17SZ125

## Non-Inverting 3-State Buffer

The NL17SZ125 is a high performance non-inverting buffer operating from a 1.65 V to 5.5 V supply.

### Features

- Extremely High Speed:  $t_{PD}$  2.6 ns (typical) at  $V_{CC} = 5.0$  V
- Designed for 1.65 V to 5.5 V  $V_{CC}$  Operation
- Overvoltage Tolerant Inputs and Outputs
- LVTTTL Compatible – Interface Capability With 5.0 V TTL Logic with  $V_{CC} = 3.0$  V
- LVCMOS Compatible
- 24 mA Balanced Output Sink and Source Capability
- Near Zero Static Supply Current Substantially Reduces System Power Requirements
- 3-State OE Input is Active-Low
- Replacement for NC7SZ125
- Chip Complexity = 36 FETs
- NLV Prefix for Automotive and Other Applications Requiring Unique Site and Control Change Requirements; AEC-Q100 Qualified and PPAP Capable
- These Devices are Pb-Free, Halogen Free/BFR Free and are RoHS Compliant

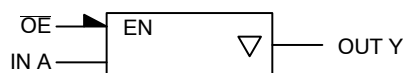


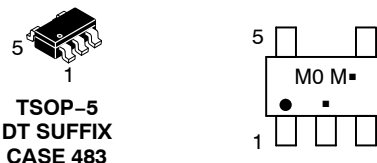
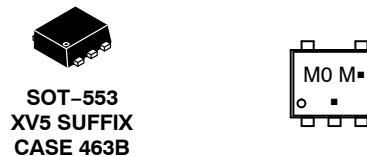
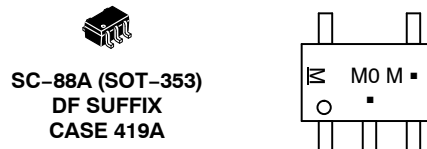
Figure 1. Logic Symbol



ON Semiconductor®

<http://onsemi.com>

### MARKING DIAGRAMS



M0 or F = Specific Device Code  
(F with 90 degree clockwise rotation)  
M = Date Code  
▪ = Pb-Free Package

(\*Note: Microdot may be in either location)

\*Date Code orientation and/or position may vary depending upon manufacturing location.

### ORDERING INFORMATION

See detailed ordering and shipping information in the package dimensions section on page 7 of this data sheet.

# NL17SZ125

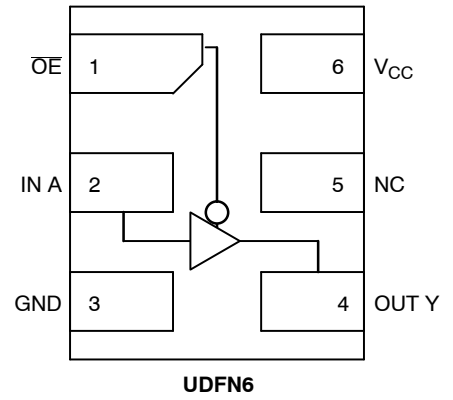
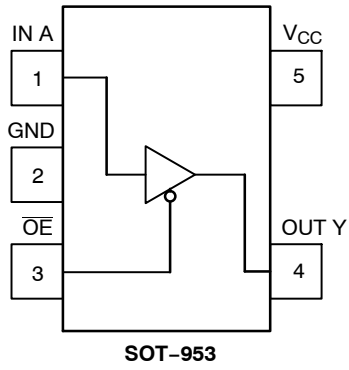
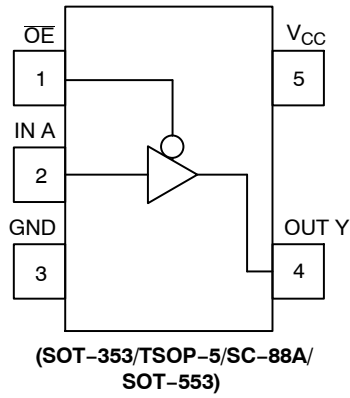


Figure 2. Pinout (Top View)

## PIN ASSIGNMENT (SOT-353/ TSOP-5/SC-88A/SOT-553)

Pin	Function
1	$\overline{OE}$
2	IN A
3	GND
4	OUT Y
5	$V_{CC}$

## PIN ASSIGNMENT (SOT-953)

Pin	Function
1	IN A
2	GND
3	$\overline{OE}$
4	OUT Y
5	$V_{CC}$

## PIN ASSIGNMENT (UDFN)

Pin	Function
1	$\overline{OE}$
2	IN A
3	GND
4	OUT Y
5	NC
6	$V_{CC}$

## FUNCTION TABLE

Input		Output
$\overline{OE}$	A	Y
L	L	L
L	H	H
H	X	Z

X = Don't Care

# NL17SZ125

## MAXIMUM RATINGS

Symbol	Parameter	Value	Units
$V_{CC}$	DC Supply Voltage	-0.5 to +7.0	V
$V_{IN}$	DC Input Voltage	-0.5 to +7.0	V
$V_{OUT}$	DC Output Voltage (SOT-353/TSOP-5/SC-88A/SOT-553/UDFN Packages)	-0.5 to $V_{CC} + 0.5$	V
$V_{OUT}$	DC Output Voltage (SOT-953 Package) Output at High or Low State Power-Down Mode ( $V_{CC} = 0$ V)	-0.5 to $V_{CC} + 0.5$ -0.5 to +0.5	V
$I_{IK}$	DC Input Diode Current	-50	mA
$I_{OK}$	DC Output Diode Current (SOT-353/TSOP-5/SC-88A/SOT-553/UDFN Packages) $V_{OUT} < GND, V_{OUT} > V_{CC}$	$\pm 50$	mA
$I_{OK}$	DC Output Diode Current (SOT-953 Package) $V_{OUT} < GND$	-50	mA
$I_{OUT}$	DC Output Sink Current	$\pm 50$	mA
$I_{CC}$	DC Supply Current per Supply Pin	$\pm 100$	mA
$T_{STG}$	Storage Temperature Range	-65 to +150	$^{\circ}C$
$T_L$	Lead Temperature, 1 mm from Case for 10 Seconds	260	$^{\circ}C$
$T_J$	Junction Temperature Under Bias	+150	$^{\circ}C$
$\theta_{JA}$	Thermal Resistance (Note 1) SC-88A/SOT-553 TSOP-5	350 230	$^{\circ}C/W$
$P_D$	Power Dissipation in Still Air at 85 $^{\circ}C$	150	mW
MSL	Moisture Sensitivity	Level 1	
$F_R$	Flammability Rating Oxygen Index: 28 to 34	UL 94 V-0 @ 0.125 in	
$V_{ESD}$	ESD Withstand Voltage Human Body Model (Note 2) Machine Model (Note 3) Charged Device Model (Note 4)	> 2000 > 200 N/A	V
$I_{LATCHUP}$	Latchup Performance Above $V_{CC}$ and Below GND at 125 $^{\circ}C$ (Note 5)	$\pm 100$	mA

Stresses exceeding Maximum Ratings may damage the device. Maximum Ratings are stress ratings only. Functional operation above the Recommended Operating Conditions is not implied. Extended exposure to stresses above the Recommended Operating Conditions may affect device reliability.

1. Measured with minimum pad spacing on an FR4 board, using 10 mm-by-1 inch, 2 ounce copper trace with no air flow.
2. Tested to EIA/JESD22-A114-A.
3. Tested to EIA/JESD22-A115-A.
4. Tested to JESD22-C101-A.
5. Tested to EIA/JESD78.

# NL17SZ125

## RECOMMENDED OPERATING CONDITIONS

Symbol	Parameter	Min	Max	Units
V <sub>CC</sub>	DC Supply Voltage	1.65	5.5	V
V <sub>IN</sub>	DC Input Voltage	0	5.5	V
V <sub>OUT</sub>	DC Output Voltage (SOT-353/TSOP-5/SC-88A/SOT-553/UDFN Packages)	0	5.5	V
V <sub>OUT</sub>	DC Output Voltage (SOT-953 Package)	0	V <sub>CC</sub>	V
T <sub>A</sub>	Operating Temperature Range	-55	+125	°C
t <sub>r</sub> , t <sub>f</sub>	Input Rise and Fall Time V <sub>CC</sub> = 1.8 V ±0.15 V V <sub>CC</sub> = 2.5 V ±0.2 V V <sub>CC</sub> = 3.0 V ±0.3 V V <sub>CC</sub> = 5.0 V ±0.5 V	0 0 0 0	20 20 10 5.0	ns/V

## DEVICE JUNCTION TEMPERATURE VERSUS TIME TO 0.1% BOND FAILURES

Junction Temperature °C	Time, Hours	Time, Years
80	1,032,200	117.8
90	419,300	47.9
100	178,700	20.4
110	79,600	9.4
120	37,000	4.2
130	17,800	2.0
140	8,900	1.0

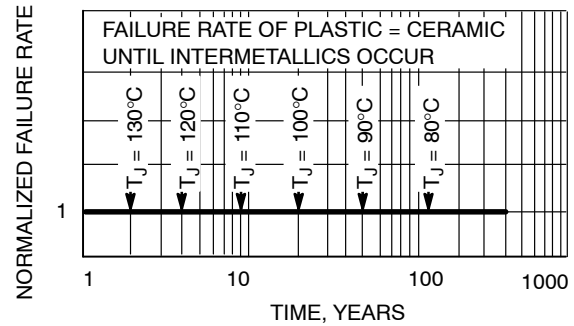


Figure 3. Failure Rate vs. Time Junction Temperature

## DC ELECTRICAL CHARACTERISTICS

Symbol	Parameter	V <sub>CC</sub> (V)	T <sub>A</sub> = 25°C			-55°C ≤ T <sub>A</sub> ≤ 125°C		Units	Condition
			Min	Typ	Max	Min	Max		
V <sub>IH</sub>	High-Level Input Voltage	1.65 to 1.95 2.3 to 5.5	0.75 V <sub>CC</sub> 0.7 V <sub>CC</sub>			0.75 V <sub>CC</sub> 0.7 V <sub>CC</sub>		V	
V <sub>IL</sub>	Low-Level Input Voltage	1.65 to 1.95 2.3 to 5.5			0.25 V <sub>CC</sub> 0.3 V <sub>CC</sub>		0.25 V <sub>CC</sub> 0.3 V <sub>CC</sub>	V	
V <sub>OH</sub>	High-Level Output Voltage V <sub>IN</sub> = V <sub>IH</sub>	1.65 1.8 2.3 3.0 4.5	1.55 1.7 2.2 2.9 4.4	1.65 1.8 2.3 3.0 4.5		1.55 1.7 2.2 2.9 4.4		V	I <sub>OH</sub> = -100 μA
		1.65 2.3 3.0 3.0 4.5	1.29 1.9 2.4 2.3 3.8	1.52 2.15 2.80 2.68 4.20		1.29 1.9 2.4 2.3 3.8		V	I <sub>OH</sub> = -4 mA I <sub>OH</sub> = -8 mA I <sub>OH</sub> = -16 mA I <sub>OH</sub> = -24 mA I <sub>OH</sub> = -32 mA
V <sub>OL</sub>	Low-Level Output Voltage V <sub>IN</sub> = V <sub>IL</sub>	1.65 1.8 2.3 3.0 4.5		0.0 0.0 0.0 0.0 0.0	0.1 0.1 0.1 0.1 0.1		0.1 0.1 0.1 0.1 0.1	V	I <sub>OL</sub> = 100 μA
		1.65 2.3 3.0 3.0 4.5		0.08 0.10 0.15 0.22 0.22	0.24 0.30 0.40 0.55 0.55		0.24 0.30 0.40 0.55 0.55	V	I <sub>OL</sub> = 4 mA I <sub>OL</sub> = 8 mA I <sub>OL</sub> = 16 mA I <sub>OL</sub> = 24 mA I <sub>OL</sub> = 32 mA

# NL17SZ125

## DC ELECTRICAL CHARACTERISTICS

Symbol	Parameter	V <sub>CC</sub> (V)	T <sub>A</sub> = 25°C			-55°C ≤ T <sub>A</sub> ≤ 125°C		Units	Condition
			Min	Typ	Max	Min	Max		
I <sub>IN</sub>	Input Leakage Current	0 to 5.5			±0.1		±1.0	μA	V <sub>IN</sub> = 5.5 V or GND
I <sub>OZ</sub>	3-State Output Leakage	1.65 to 5.5			±0.5		±5.0	μA	V <sub>IN</sub> = V <sub>IH</sub> or V <sub>IL</sub> 0 V ≤ V <sub>OUT</sub> ≤ 5.5 V
I <sub>OFF</sub>	Power Off Leakage Current (SOT-353/TSOP-5/SC-88A/SOT-553/UDFN Packages)	0			1.0		10	μA	V <sub>IN</sub> = 5.5 V or V <sub>OUT</sub> = 5.5 V
I <sub>CC</sub>	Quiescent Supply Current	5.5			1.0		10	μA	V <sub>IN</sub> = 5.5 V or GND

## AC ELECTRICAL CHARACTERISTICS (t<sub>R</sub> = t<sub>F</sub> = 3.0 ns)

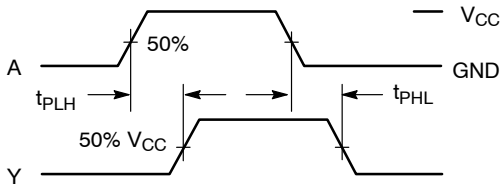
Symbol	Parameter	Condition	V <sub>CC</sub> (V)	T <sub>A</sub> = 25°C			-55°C ≤ T <sub>A</sub> ≤ 125°C		Units
				Min	Typ	Max	Min	Max	
t <sub>PLH</sub> t <sub>PHL</sub>	Propagation Delay AN to YN (Figures 4 and 5, Table 1)	R <sub>L</sub> = 1 MΩ C <sub>L</sub> = 15 pF	1.8 ± 0.15	2.0	9.0	10	2.0	10.5	ns
		R <sub>L</sub> = 1 MΩ C <sub>L</sub> = 15 pF	2.5 ± 0.2	1.0		7.5	1.0	8.0	
		R <sub>L</sub> = 1 MΩ C <sub>L</sub> = 15 pF R <sub>L</sub> = 500 Ω C <sub>L</sub> = 50 pF	3.3 ± 0.3	0.8		5.2 5.7	0.8	5.5 6.0	
		R <sub>L</sub> = 1 MΩ C <sub>L</sub> = 15 pF R <sub>L</sub> = 500 Ω C <sub>L</sub> = 50 pF	5.0 ± 0.5	0.5		4.5 5.0	0.5	4.8 5.3	
t <sub>PZH</sub> t <sub>PZL</sub>	Output Enable Time (Figures 6, 7 and 8, Table 1)	R <sub>L</sub> = 250 Ω C <sub>L</sub> = 50 pF	1.8 ± 0.15	2.0	7.6	9.5	2.0	10	ns
			2.5 ± 0.2	1.8		8.5	1.8	9.0	
			3.3 ± 0.3	1.2		6.2	1.2	6.5	
			5.0 ± 0.5	0.8		5.5	0.8	5.8	
t <sub>PHZ</sub> t <sub>PLZ</sub>	Output Disable Time (Figures 6, 7 and 8, Table 1)	R <sub>L</sub> and R <sub>1</sub> = 500 Ω C <sub>L</sub> = 50 pF	1.8 ± 0.15	2.0	8.0	10	2.0	10.5	ns
			2.5 ± 0.2	1.5		8.0	1.5	8.5	
			3.3 ± 0.3	0.8		5.7	0.8	6.0	
			5.0 ± 0.5	0.3		4.7	0.3	5.0	

## CAPACITIVE CHARACTERISTICS

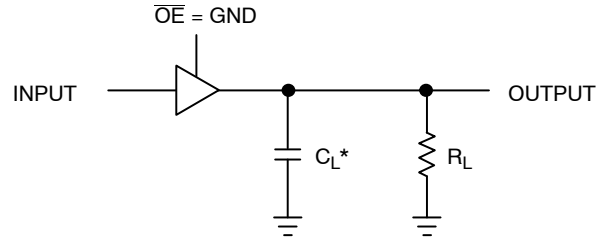
Symbol	Parameter	Condition	Typical	Units
C <sub>IN</sub>	Input Capacitance	V <sub>CC</sub> = 5.5 V, V <sub>I</sub> = 0 V or V <sub>CC</sub>	2.5	pF
C <sub>OUT</sub>	Output Capacitance	V <sub>CC</sub> = 5.5 V, V <sub>I</sub> = 0 V or V <sub>CC</sub>	2.5	pF
C <sub>PD</sub>	Power Dissipation Capacitance (Note 6)	10 MHz, V <sub>CC</sub> = 3.3 V, V <sub>I</sub> = 0 V or V <sub>CC</sub> 10 MHz, V <sub>CC</sub> = 5.5 V, V <sub>I</sub> = 0 V or V <sub>CC</sub>	9 11	pF

6. C<sub>PD</sub> is defined as the value of the internal equivalent capacitance which is calculated from the operating current consumption without load. Average operating current can be obtained by the equation: I<sub>CC(OPR)</sub> = C<sub>PD</sub> • V<sub>CC</sub> • f<sub>in</sub> + I<sub>CC</sub>. C<sub>PD</sub> is used to determine the no-load dynamic power consumption; P<sub>D</sub> = C<sub>PD</sub> • V<sub>CC</sub><sup>2</sup> • f<sub>in</sub> + I<sub>CC</sub> • V<sub>CC</sub>.

# NL17SZ125

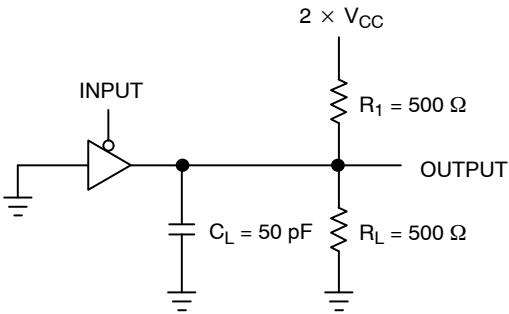


**Figure 4. Switching Waveform**



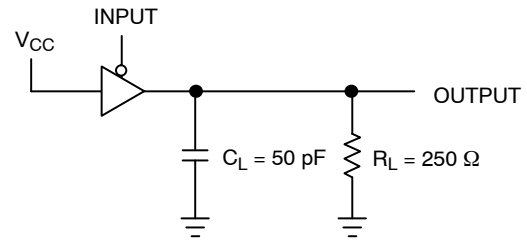
\*Includes all probe and jig capacitance.  
A 1 MHz square input wave is recommended for propagation delay tests.

**Figure 5.  $t_{PLH}$  or  $t_{PHL}$**



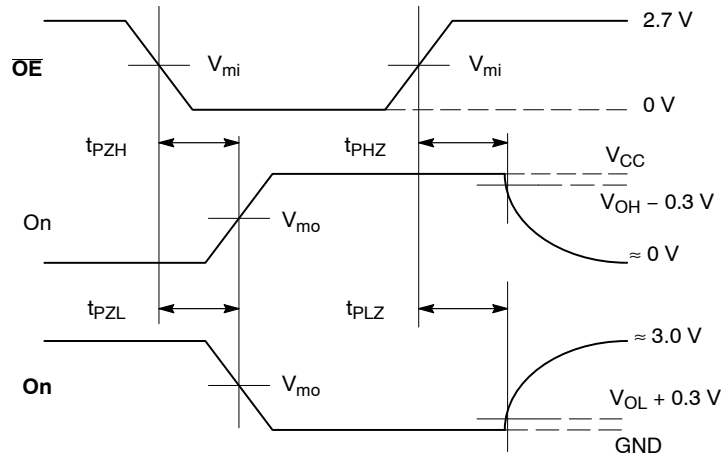
A 1 MHz square input wave is recommended for propagation delay tests.

**Figure 6.  $t_{PZL}$  or  $t_{PLZ}$**



A 1 MHz square input wave is recommended for propagation delay tests.

**Figure 7.  $t_{PZH}$  or  $t_{PHZ}$**



**Figure 8. AC Output Enable and Disable Waveform**

**Table 1. OUTPUT ENABLE AND DISABLE TIMES**

$t_R = t_F = 2.5$  ns, 10% to 90%;  $f = 1$  MHz;  $t_W = 500$  ns

Symbol	$V_{CC}$		
	$3.3 \text{ V} \pm 0.3 \text{ V}$	$2.7 \text{ V}$	$2.5 \text{ V} \pm 0.2 \text{ V}$
$V_{mi}$	1.5 V	1.5 V	$V_{CC}/2$
$V_{mo}$	1.5 V	1.5 V	$V_{CC}/2$

# NL17SZ125

## DEVICE ORDERING INFORMATION

Device	Package	Shipping†
NL17SZ125DFT2G	SC-88A (SOT-353) (Pb-Free)	3000 / Tape & Reel
NLV17SZ125DFT2G*	SC-88A (SOT-353) (Pb-Free)	3000 / Tape & Reel
NL17SZ125XV5T2G	SOT-553 (Pb-Free)	4000 / Tape & Reel
NL17SZ125DTT1G	TSOP-5 (Pb-Free)	3000 / Tape & Reel
NL17SZ125CMUTCG	UDFN6, 1.0 x 1.0 x 0.35P (Pb-Free)	3000 / Tape & Reel
NL17SZ125P5T5G	SOT-953 (Pb-Free)	8000 / Tape & Reel

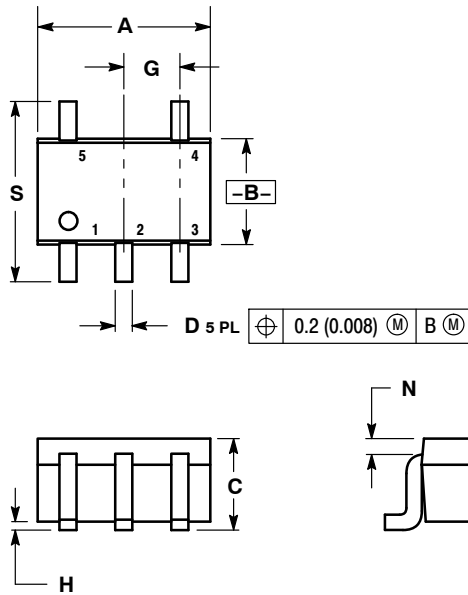
†For information on tape and reel specifications, including part orientation and tape sizes, please refer to our Tape and Reel Packaging Specifications Brochure, BRD8011/D.

\*NLV Prefix for Automotive and Other Applications Requiring Unique Site and Control Change Requirements; AEC-Q100 Qualified and PPAP Capable.

# NL17SZ125

## PACKAGE DIMENSIONS

SC-88A (SC-70-5/SOT-353)  
CASE 419A-02  
ISSUE L

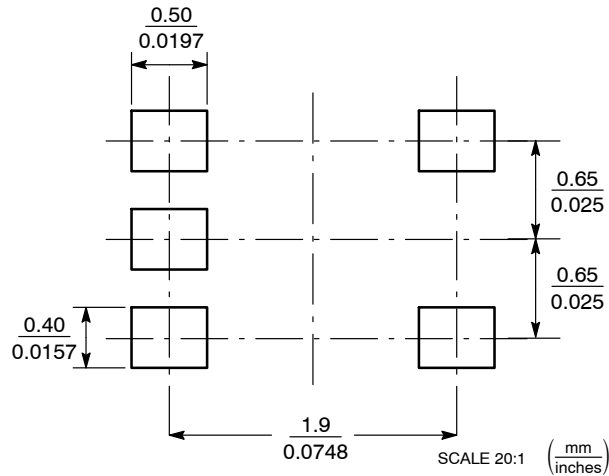


NOTES:

1. DIMENSIONING AND TOLERANCING PER ANSI Y14.5M, 1982.
2. CONTROLLING DIMENSION: INCH.
3. 419A-01 OBSOLETE. NEW STANDARD 419A-02.
4. DIMENSIONS A AND B DO NOT INCLUDE MOLD FLASH, PROTRUSIONS, OR GATE BURRS.

DIM	INCHES		MILLIMETERS	
	MIN	MAX	MIN	MAX
A	0.071	0.087	1.80	2.20
B	0.045	0.053	1.15	1.35
C	0.031	0.043	0.80	1.10
D	0.004	0.012	0.10	0.30
G	0.026 BSC		0.65 BSC	
H	---	0.004	---	0.10
J	0.004	0.010	0.10	0.25
K	0.004	0.012	0.10	0.30
N	0.008 REF		0.20 REF	
S	0.079	0.087	2.00	2.20

### SOLDER FOOTPRINT\*



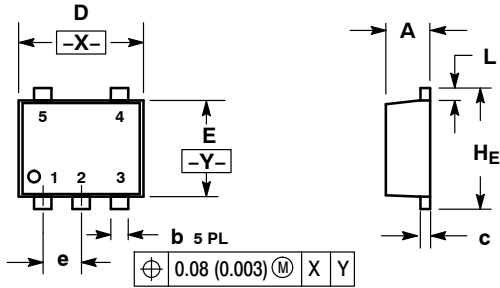
\*For additional information on our Pb-Free strategy and soldering details, please download the ON Semiconductor Soldering and Mounting Techniques Reference Manual, SOLDERRM/D.



# NL17SZ125

## PACKAGE DIMENSIONS

SOT-553, 5 LEAD  
CASE 463B  
ISSUE B

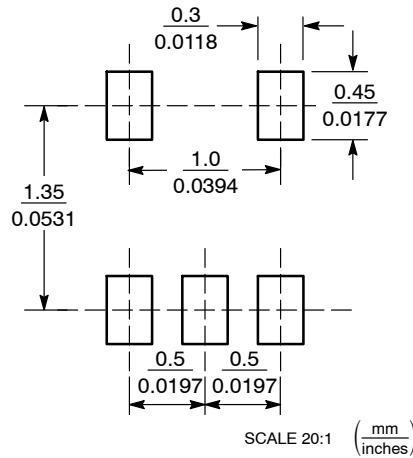


NOTES:

1. DIMENSIONING AND TOLERANCING PER ANSI Y14.5M, 1982.
2. CONTROLLING DIMENSION: MILLIMETERS
3. MAXIMUM LEAD THICKNESS INCLUDES LEAD FINISH THICKNESS. MINIMUM LEAD THICKNESS IS THE MINIMUM THICKNESS OF BASE MATERIAL.

DIM	MILLIMETERS			INCHES		
	MIN	NOM	MAX	MIN	NOM	MAX
A	0.50	0.55	0.60	0.020	0.022	0.024
b	0.17	0.22	0.27	0.007	0.009	0.011
c	0.08	0.13	0.18	0.003	0.005	0.007
D	1.50	1.60	1.70	0.059	0.063	0.067
E	1.10	1.20	1.30	0.043	0.047	0.051
e	0.50 BSC			0.020 BSC		
L	0.10	0.20	0.30	0.004	0.008	0.012
HE	1.50	1.60	1.70	0.059	0.063	0.067

### SOLDERING FOOTPRINT\*

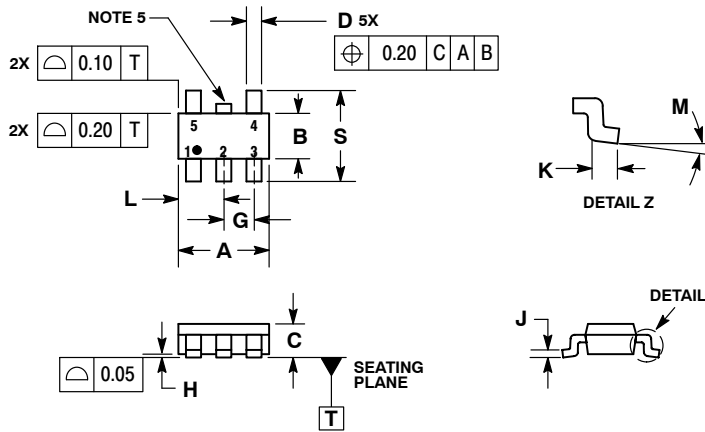


\*For additional information on our Pb-Free strategy and soldering details, please download the ON Semiconductor Soldering and Mounting Techniques Reference Manual, SOLDERRM/D.

# NL17SZ125

## PACKAGE DIMENSIONS

### TSOP-5 CASE 483-02 ISSUE H

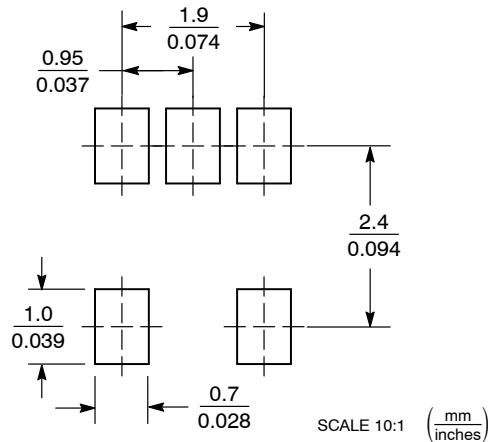


#### NOTES:

1. DIMENSIONING AND TOLERANCING PER ASME Y14.5M, 1994.
2. CONTROLLING DIMENSION: MILLIMETERS.
3. MAXIMUM LEAD THICKNESS INCLUDES LEAD FINISH THICKNESS. MINIMUM LEAD THICKNESS IS THE MINIMUM THICKNESS OF BASE MATERIAL.
4. DIMENSIONS A AND B DO NOT INCLUDE MOLD FLASH, PROTRUSIONS, OR GATE BURRS.
5. OPTIONAL CONSTRUCTION: AN ADDITIONAL TRIMMED LEAD IS ALLOWED IN THIS LOCATION. TRIMMED LEAD NOT TO EXTEND MORE THAN 0.2 FROM BODY.

MILLIMETERS		
DIM	MIN	MAX
A	3.00	BSC
B	1.50	BSC
C	0.90	1.10
D	0.25	0.50
G	0.95	BSC
H	0.01	0.10
J	0.10	0.26
K	0.20	0.60
L	1.25	1.55
M	0°	10°
S	2.50	3.00

#### SOLDERING FOOTPRINT\*

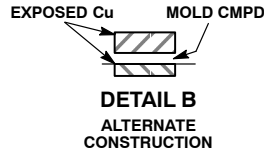
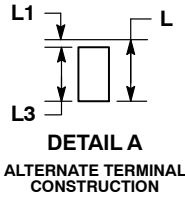
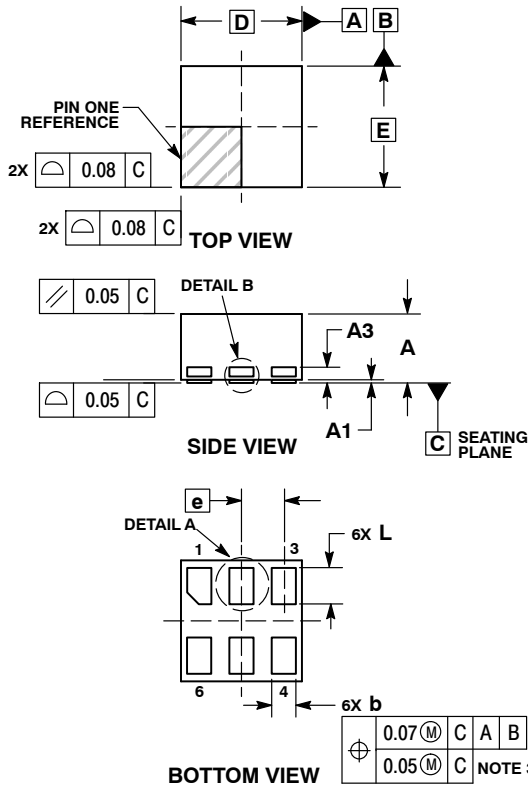


\*For additional information on our Pb-Free strategy and soldering details, please download the ON Semiconductor Soldering and Mounting Techniques Reference Manual, SOLDERRM/D.

# NL17SZ125

## PACKAGE DIMENSIONS

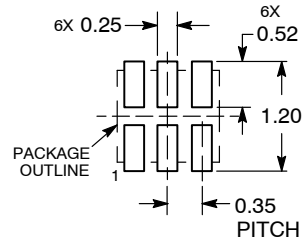
UDFN6, 1x1, 0.35P  
CASE 517BX  
ISSUE O



- NOTES:
1. DIMENSIONING AND TOLERANCING PER ASME Y14.5M, 1994.
  2. CONTROLLING DIMENSION: MILLIMETERS.
  3. DIMENSION b APPLIES TO PLATED TERMINAL AND IS MEASURED BETWEEN 0.15 AND 0.20 MM FROM TERMINAL TIP.
  4. PACKAGE DIMENSIONS EXCLUSIVE OF BURRS AND MOLD FLASH.

DIM	MILLIMETERS	
	MIN	MAX
A	0.50	0.65
A1	0.00	0.05
A3	0.13 REF	
b	0.17	0.23
D	1.00 BSC	
E	1.00 BSC	
e	0.35	
L	0.20	0.40
L1	---	0.15
L3	0.26	0.33

### RECOMMENDED SOLDERING FOOTPRINT\*



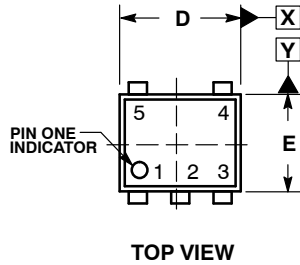
DIMENSION: MILLIMETERS

\*For additional information on our Pb-Free strategy and soldering details, please download the ON Semiconductor Soldering and Mounting Techniques Reference Manual, SOLDERRM/D.

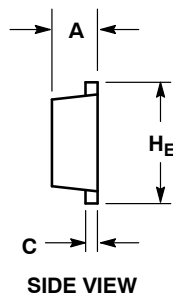
# NL17SZ125

## PACKAGE DIMENSIONS

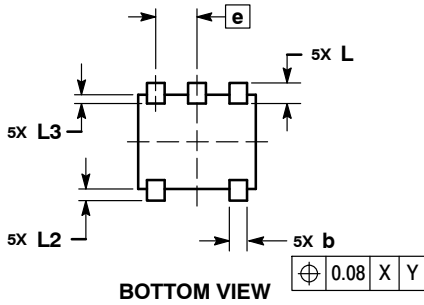
SOT-953  
CASE 527AE  
ISSUE E



TOP VIEW



SIDE VIEW



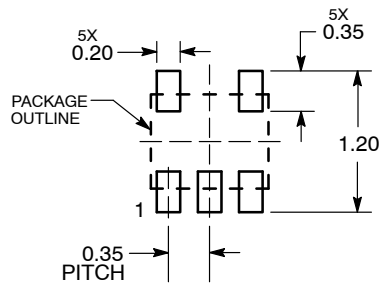
BOTTOM VIEW

NOTES:

1. DIMENSIONING AND TOLERANCING PER ASME Y14.5M, 1994.
2. CONTROLLING DIMENSION: MILLIMETERS
3. MAXIMUM LEAD THICKNESS INCLUDES LEAD FINISH. MINIMUM LEAD THICKNESS IS THE MINIMUM THICKNESS OF THE BASE MATERIAL.
4. DIMENSIONS D AND E DO NOT INCLUDE MOLD FLASH, PROTRUSIONS, OR GATE BURRS.

DIM	MILLIMETERS		
	MIN	NOM	MAX
A	0.34	0.37	0.40
b	0.10	0.15	0.20
C	0.07	0.12	0.17
D	0.95	1.00	1.05
E	0.75	0.80	0.85
e	0.35 BSC		
H <sub>E</sub>	0.95	1.00	1.05
L	0.175 REF		
L2	0.05	0.10	0.15
L3	---	---	0.15

### SOLDERING FOOTPRINT\*



DIMENSIONS: MILLIMETERS

\*For additional information on our Pb-Free strategy and soldering details, please download the ON Semiconductor Soldering and Mounting Techniques Reference Manual, SOLDERRM/D.

ON Semiconductor and are registered trademarks of Semiconductor Components Industries, LLC (SCILLC). SCILLC owns the rights to a number of patents, trademarks, copyrights, trade secrets, and other intellectual property. A listing of SCILLC's product/patent coverage may be accessed at [www.onsemi.com/site/pdf/Patent-Marking.pdf](http://www.onsemi.com/site/pdf/Patent-Marking.pdf). SCILLC reserves the right to make changes without further notice to any products herein. SCILLC makes no warranty, representation or guarantee regarding the suitability of its products for any particular purpose, nor does SCILLC assume any liability arising out of the application or use of any product or circuit, and specifically disclaims any and all liability, including without limitation special, consequential or incidental damages. "Typical" parameters which may be provided in SCILLC data sheets and/or specifications can and do vary in different applications and actual performance may vary over time. All operating parameters, including "Typicals" must be validated for each customer application by customer's technical experts. SCILLC does not convey any license under its patent rights nor the rights of others. SCILLC products are not designed, intended, or authorized for use as components in systems intended for surgical implant into the body, or other applications intended to support or sustain life, or for any other application in which the failure of the SCILLC product could create a situation where personal injury or death may occur. Should Buyer purchase or use SCILLC products for any such unintended or unauthorized application, Buyer shall indemnify and hold SCILLC and its officers, employees, subsidiaries, affiliates, and distributors harmless against all claims, costs, damages, and expenses, and reasonable attorney fees arising out of, directly or indirectly, any claim of personal injury or death associated with such unintended or unauthorized use, even if such claim alleges that SCILLC was negligent regarding the design or manufacture of the part. SCILLC is an Equal Opportunity/Affirmative Action Employer. This literature is subject to all applicable copyright laws and is not for resale in any manner.

### PUBLICATION ORDERING INFORMATION

**LITERATURE FULFILLMENT:**  
Literature Distribution Center for ON Semiconductor  
P.O. Box 5163, Denver, Colorado 80217 USA  
**Phone:** 303-675-2175 or 800-344-3860 Toll Free USA/Canada  
**Fax:** 303-675-2176 or 800-344-3867 Toll Free USA/Canada  
**Email:** [orderlit@onsemi.com](mailto:orderlit@onsemi.com)

**N. American Technical Support:** 800-282-9855 Toll Free  
USA/Canada  
**Europe, Middle East and Africa Technical Support:**  
Phone: 421 33 790 2910  
**Japan Customer Focus Center**  
Phone: 81-3-5817-1050

**ON Semiconductor Website:** [www.onsemi.com](http://www.onsemi.com)  
**Order Literature:** <http://www.onsemi.com/orderlit>  
For additional information, please contact your local Sales Representative

# Mouser Electronics

Authorized Distributor

Click to View Pricing, Inventory, Delivery & Lifecycle Information:

[ON Semiconductor:](#)

[NL17SZ125DFT2](#)