

# Pololu IR Beacon

## Quick-Start Sheet

### Overview

The Pololu IR beacons (infrared beacons) are small devices that allow pairs of autonomous robots to detect each other. You can use the beacons to build pairs of robots that interact or chase one another, or to make a robot that can identify and return to a home base. For example, you could build a "cat robot" and "mouse robot" that each have an IR beacon, where the cat chases the mouse and the mouse runs away from the cat.

### Contacting Pololu

You can check the Pololu web site at <http://www.pololu.com/> for additional information about the IR beacon, including color pictures, application examples, and troubleshooting tips.

We would be delighted to hear from you about your project and about your experience with our product. You can contact us through our online feedback form or by email at [support@pololu.com](mailto:support@pololu.com). Tell us what we did well, what we could improve, what you would like to see in the future, or anything else you would like to say!

### Assembling the IR Beacon

Most of the IR beacon components are pre-assembled on the IR beacon using surface-mount components. All you need to do is solder in the large capacitor, the sensors, and the connections to your main robot controller. **The capacitor is polarized**, so make sure to solder it in with the positive lead in the hole marked with a '+'. **All other components must be installed from the bottom of the PCB.** You can install the IR detectors directly into the PCB, or you can solder them onto wires that you solder into the PCB (this would give you more flexibility in positioning the detectors on your system).

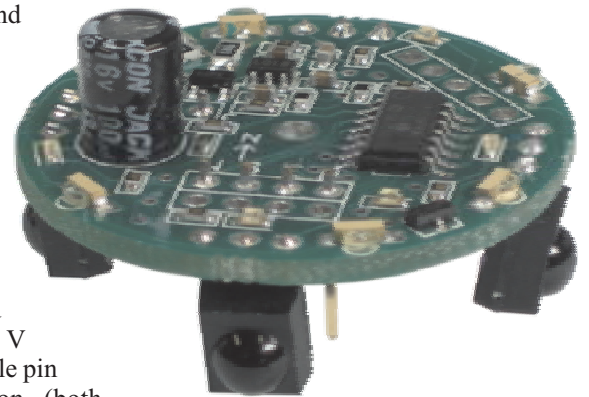
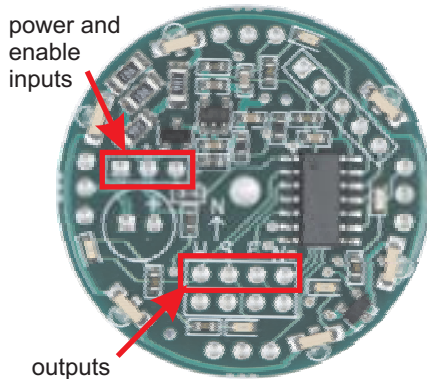

There are two sets of electrical connections to the IR beacon. Three pins on the "west" side are for power and an optional enable input. Apply 6-16 V across the + and - pins; making the enable pin high (5 V) will enable the beacon (both transmission and reception). The four directional outputs are located on the "south" side of the PCB. Each pin is normally high (5 V), and it will go low (0 V) if the other beacon is detected in the corresponding direction.

### Mounting Considerations

The IR beacon should be mounted at the highest point on your robot so that it is not obstructed in any direction. Close-range performance can be improved by installing optical shielding between sensors; note that some materials that seem opaque are transparent to IR.

### Specifications

PCB Size:	1.35"-diameter circle
IR Modulation Frequency:	56 kHz
Output Refresh Rate:	20 Hz
Detection Range:	Approximately 6 inches to 20 feet
Supply Voltage:	6-16V
Data Voltage:	0-5V

# Mouser Electronics

Authorized Distributor

Click to View Pricing, Inventory, Delivery & Lifecycle Information:

[Parallax:](#)

[28049](#)