

STK672-040GEVB, STK672-050GEVB, STK672-060GEVB



ON Semiconductor®

<http://onsemi.com>

STK672 Series Evaluation Board User's Manual

Thick-Film Hybrid IC Unipolar
Constant-current Chopper (external
Excitation PWM) Circuit with Built-in
Microstepping Controller Stepping Motor
Driver (sine wave drive)

EVAL BOARD USER'S MANUAL

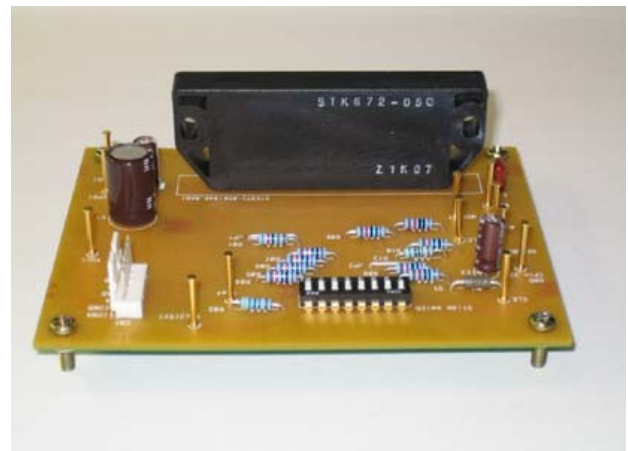

Figure 1. STK672 Series Evaluation Boards

This Evaluation Board User's Manual describes the set-up and use of the STK672 Series Evaluation Board for SANYO Semiconductor (An ON Semiconductor Company) Thick-Film Hybrid IC Unipolar Constant-Current Chopper Circuit with Built-in Microstepping Controller Stepping Motor Driver devices STK672-040-E, STK672-050-E, and STK672-060-E. For datasheets and additional information on these devices, please visit the ON Semiconductor website at www.onsemi.com

STK672-040GEVB, STK672-050GEVB, STK672-060GEVB

EVALUATION BOARD

STK672-040-E and STK672-060-E (100.0 mm x 80.0 mm x 1.6 mm, phenol 1-layer board)

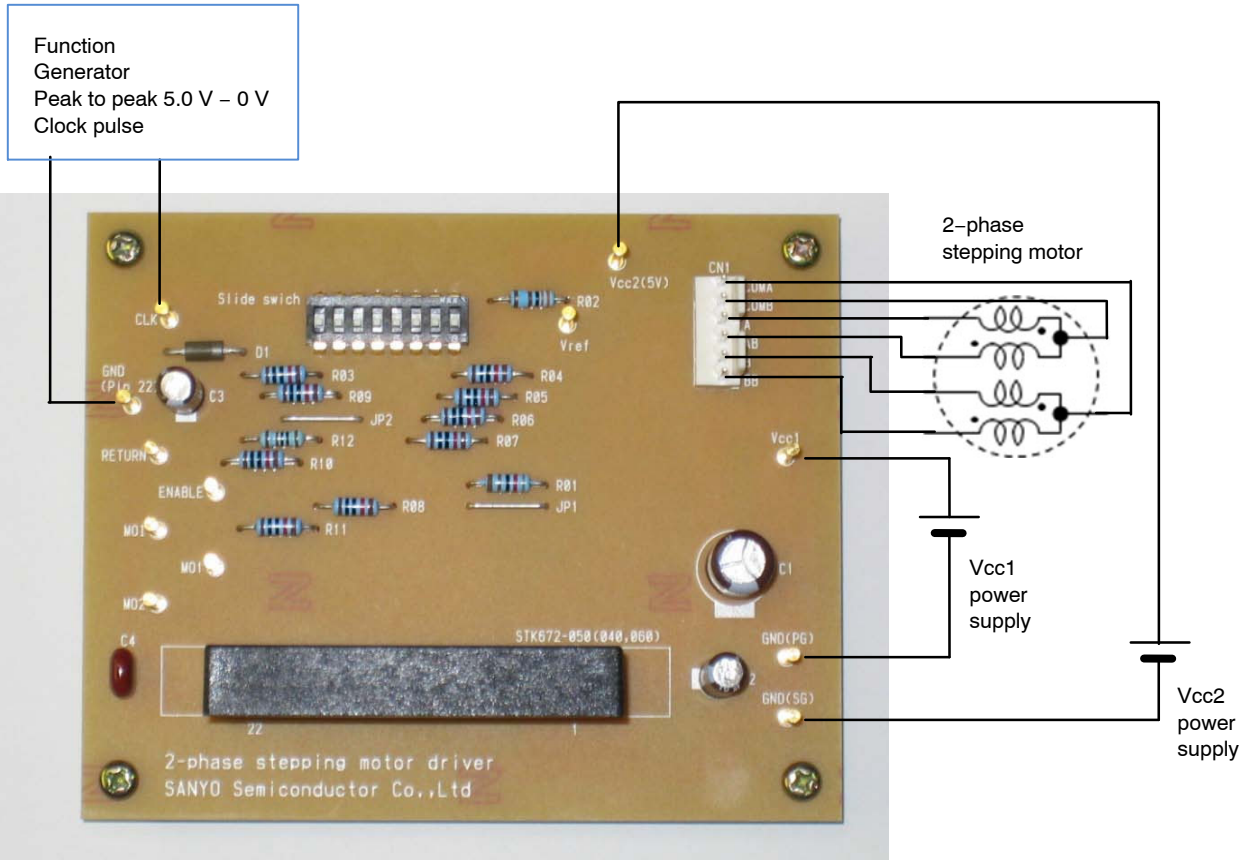

Figure 2. STK672-040-E / STK672-060-E Evaluation Board

STK672-040GEVB, STK672-050GEVB, STK672-060GEVB

EVALUATION BOARD

STK672-050-E (100.0 mm x 80.0 mm x 1.6 mm, phenol 1-layer board)

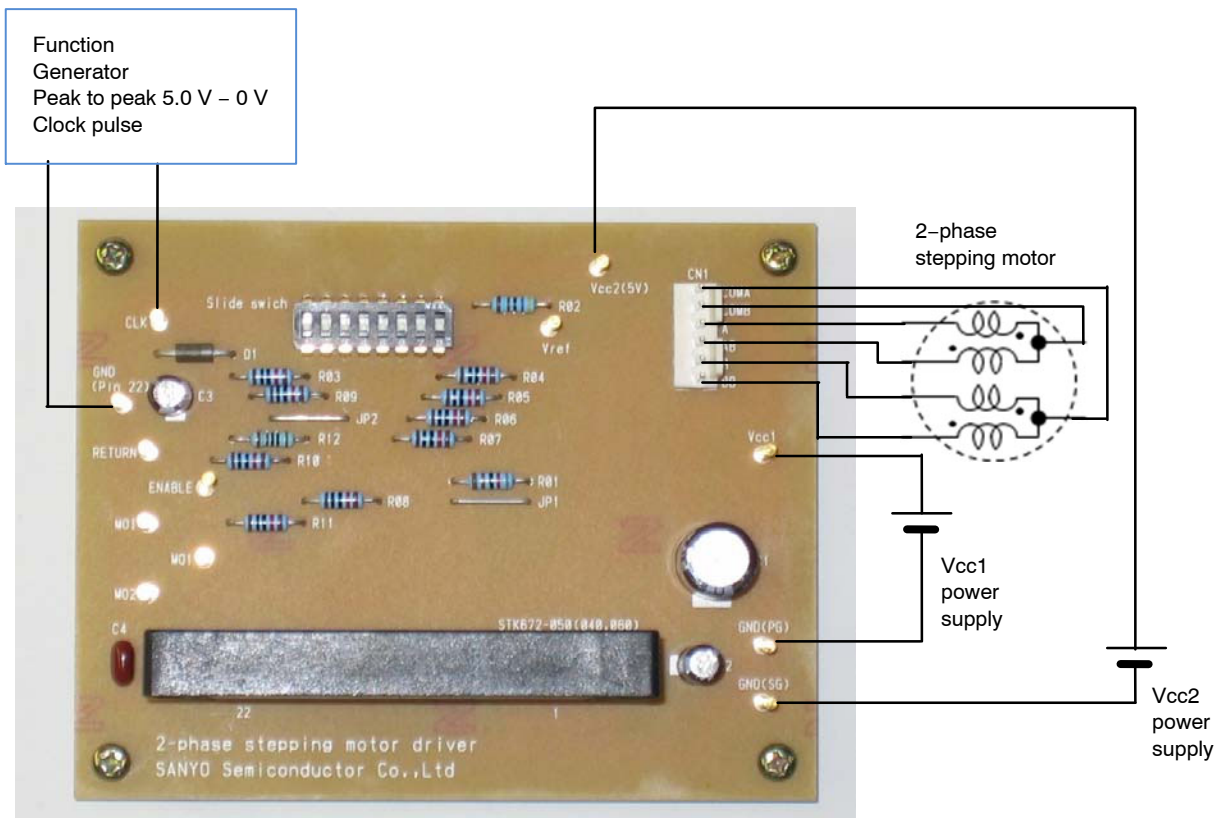
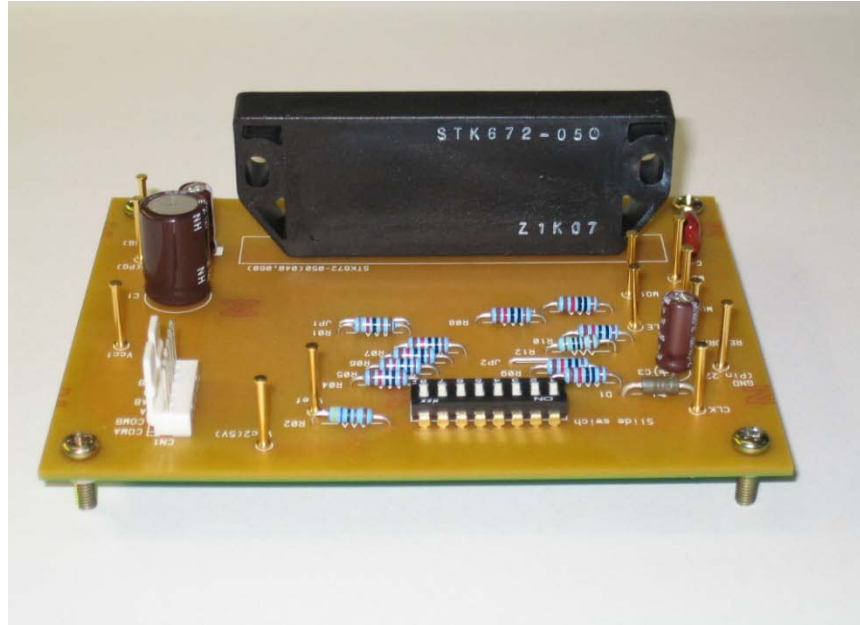

Figure 3. STK672-050-E Evaluation Board

STK672-040GEVB, STK672-050GEVB, STK672-060GEVB

SUBSTRATE SPECIFICATIONS

(Substrate recommended for operation of STK672-050-E)

Size: 100 mm x 80 mm x 1.6 mm 1-layer board

Material: Phenol

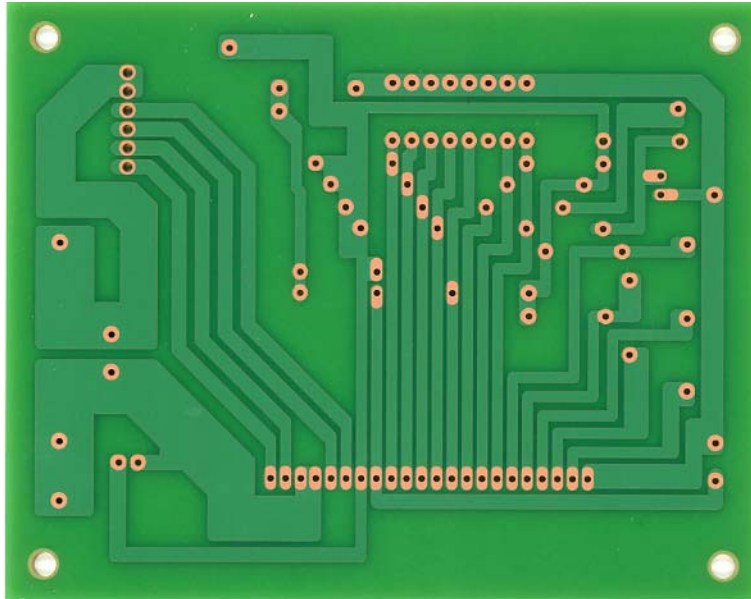

Figure 4. Copper Side (35 μ)

ALLOWABLE POWER DISSIPATION (Reference value)

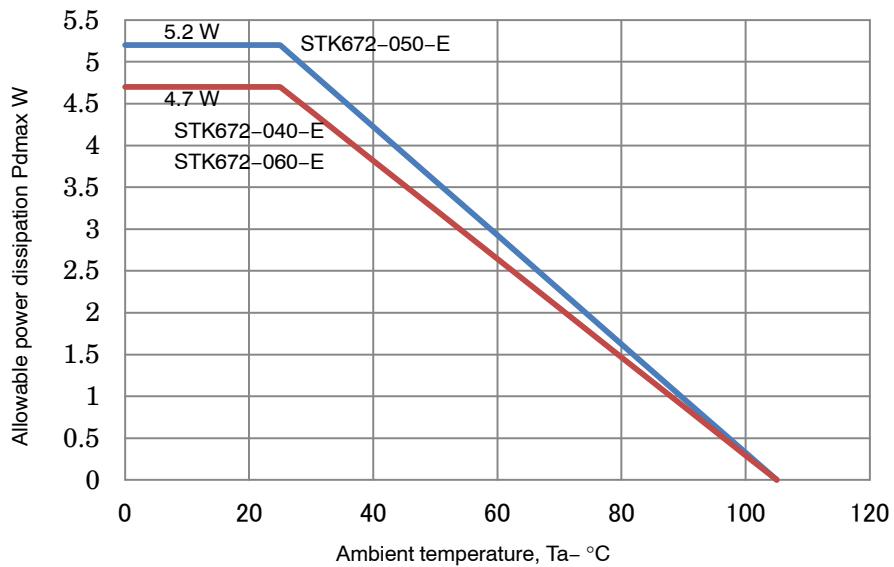

Figure 5. Allowable Power Dissipation

EVALUATION CIRCUIT

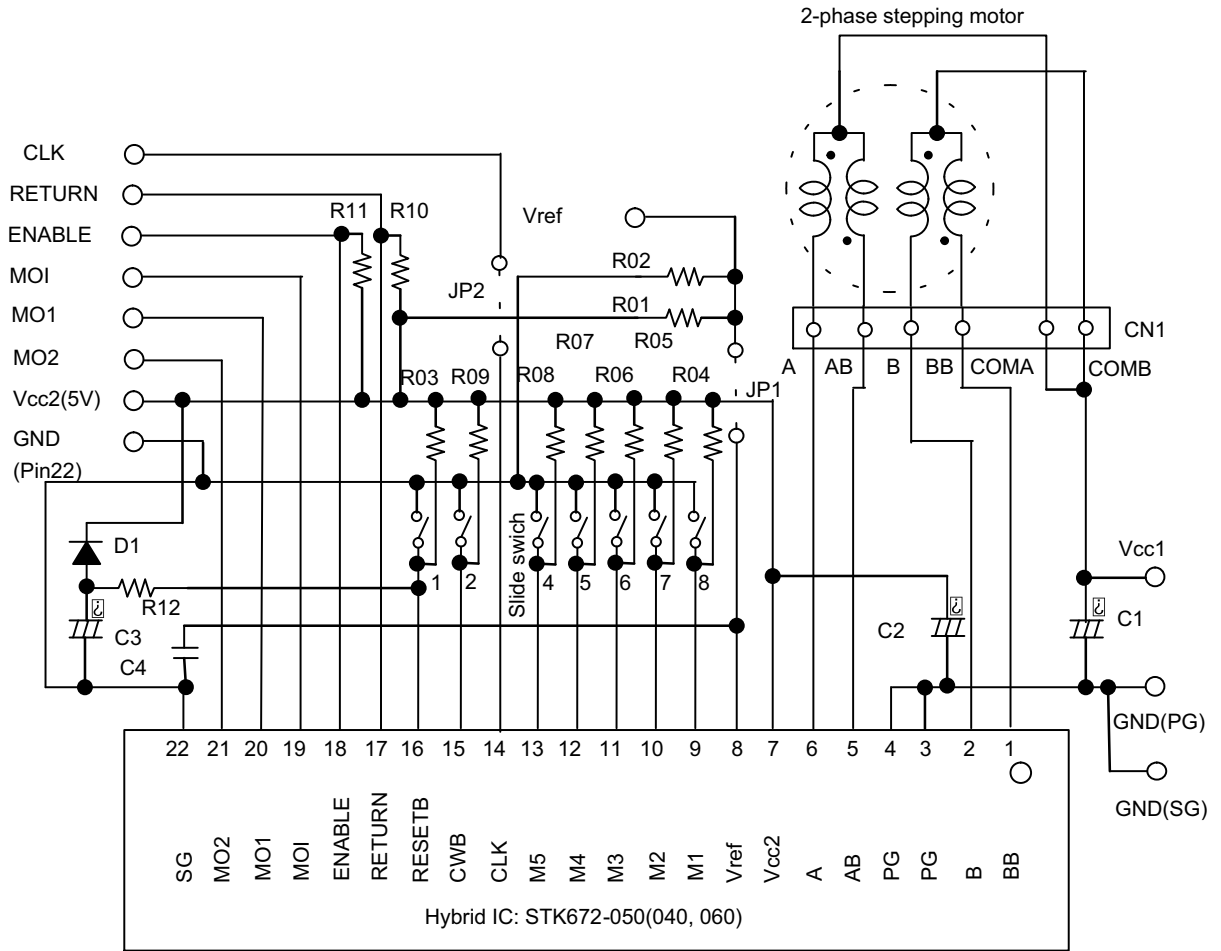

Figure 6. Evaluation Circuit

STK672-040GEVB, STK672-050GEVB, STK672-060GEVB

BILL OF MATERIALS

Table 1. BILL OF MATERIALS FOR STK672-050-E EVALUATION BOARD

Designator	QTY	Description	Value	Tolerance	Foot-print	Manufacturer	Manufacturer Part Number	Substitution Allowed	Lead Free
C1	1	Vcc1 Bypass Capacitor	220 μ F / 50 V	\pm 20%		SUN ELECTRONICS	50ME220CA	YES	YES
C2	1	Vcc2 Bypass Capacitor	10 μ F / 50 V	\pm 20%		SUN ELECTRONICS	50ME10CA	YES	YES
C3	1	Capacitor for power on reset circuit	10 μ F / 50 V	\pm 20%		SUN ELECTRONICS	50ME10CA	YES	YES
C4	1	Vref stabilization Capacitor	0.1 μ F / 50 V	\pm 10%		Panasonic	ECQV1H104JL2	YES	YES
R01	1	Resistor to set Vref		\pm 1%		AKAHANE ELECTRONICS	RN14S****FK	YES	YES
R02	1	Resistor to set Vref		\pm 1%		AKAHANE ELECTRONICS	RN14S****FK	YES	YES
R03 to R11	9	Pull-up Resistor	10 k Ω	\pm 5%		AKAHANE ELECTRONICS	RN14S103JK	YES	YES
R12	1	Resistor for power on reset circuit	1 k Ω	\pm 5%		AKAHANE ELECTRONICS	RN14S102JK	YES	YES
D1	1	Diode for power on reset circuit				SANYO Semiconductor (An ON Semiconductor Company)	DS135AE	YES	YES
HIC	1	Hybrid IC				SANYO Semiconductor (An ON Semiconductor Company)	STK672-050	NO	YES
CN1	1	Vertical Header				MOLEX	5045-06A	YES	YES
Slide switch	1	Dip slide switch				NIHON KAIHEIKI	JS01-08AP4-ST	YES	YES
JP1, JP2	2	Jumper				Mac-Eight	JR-4	YES	YES
TP1 to TP12	12	Test Point				Mac-Eight	ST-1-3	YES	YES

NOTE: R01 and R02 are used to Vref for current setting.
Therefore their value is not mentioned in this table.

STK672-040GEVB, STK672-050GEVB, STK672-060GEVB

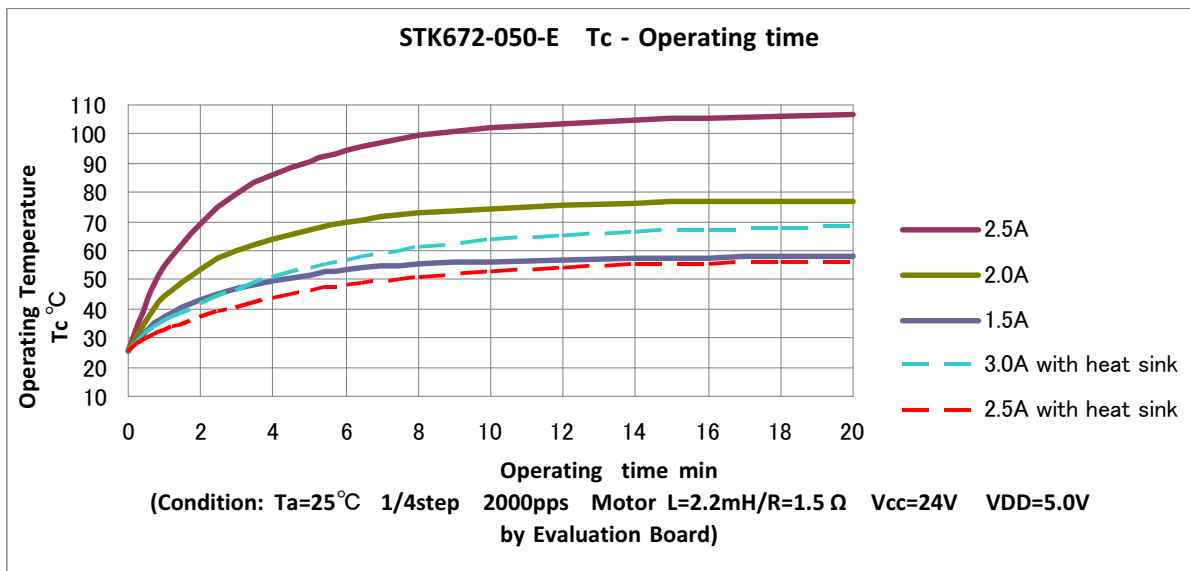
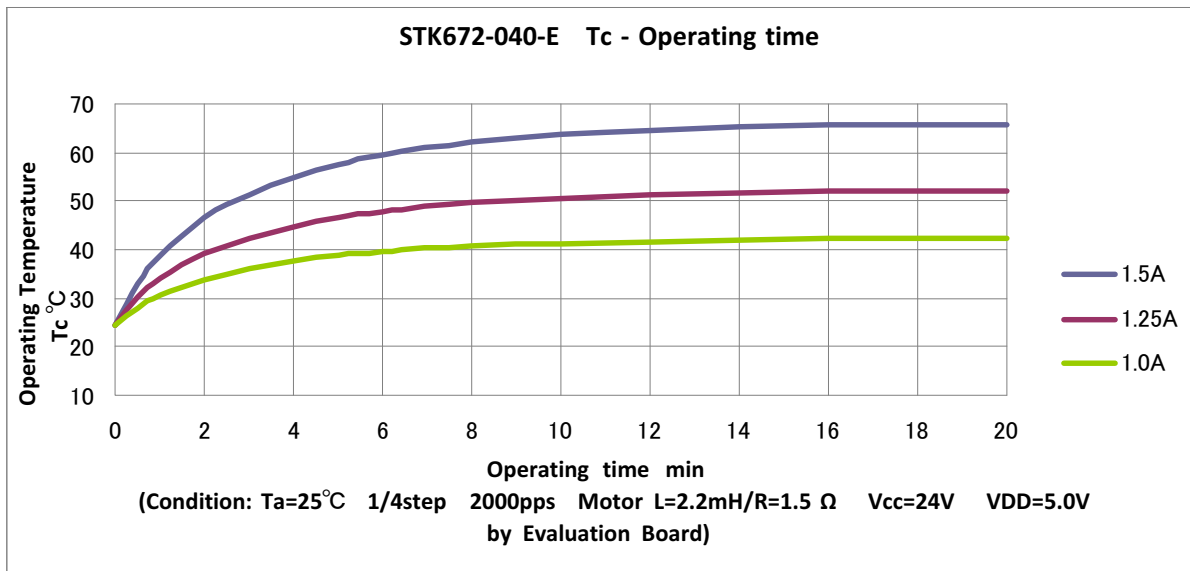
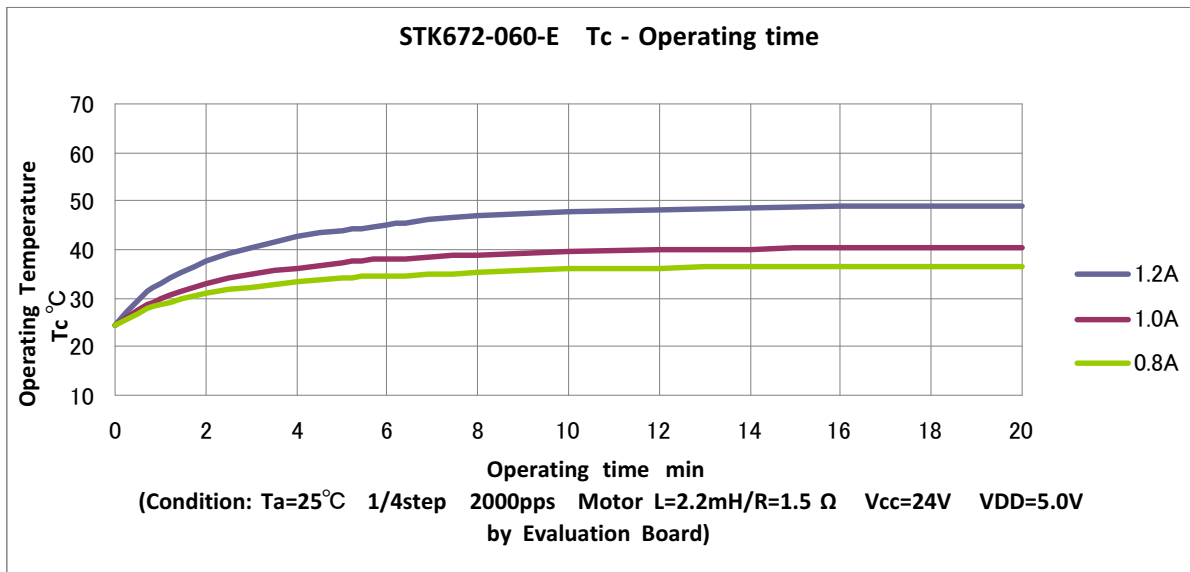

Figure 7. Operating Temperature

STK672-040GEVB, STK672-050GEVB, STK672-060GEVB

NOTES: Heat sink size used in STK672-050-E
IOH = 3.0 A and 2.5 A: 100 mm X 70 mm X
2.0 mm Al plate (no surface finish)
The Tc temperature should be checked in the
center of the metal surface of the product
package.

EVALUATION BOARD SETUP

[Supply Voltage]

Vcc1 (10 to 45 V): Power Supply for stepping motor
Vref (0 to 2.5 V): Const. Current Control for Reference
Voltage
Vcc2 (5 V): Power Supply for internal logic IC

[Toggle Switch State]

ON Side: Low (GND)
OFF Side: High (5 V pull up resistors)

[Operation Guide]

1. Motor Connection:
Connect the stepping motor to A, AB, B, BB,
COMA, and COMB.
2. Initial Condition Setting:
Set "ON" the slide switch RESETB, and set "ON
or OFF" M1 to M5 depend on step mode, and set
"ON or OFF" CWB, and set low CLK.
3. Power Supply:
At first, supply DC voltage to Vcc2, and VREF.
Next, supply DC voltage to Vcc1.
4. Ready for Operation from Standby State:
Turn "OFF" the slide switch RESETB.
Output A and BB are set initial position 70%.
5. Motor Operation:
Input the CLK signal into the terminal CLK.

[Setting the motor current]

The motor current IOH is set by the Vref voltage on the
hybrid IC pin 8. The following formula gives the
relationship between IOH and Vref.

STK672-040-E

$IOH = (1/3) \times Vref / Rs$, Rs: The hybrid IC internal current
detection resistor (0.33 Ω 3%)
 $Vref = Vcc2 (5.0 V) \times R02 / (R01 + R02) = IOH \times Rs \times 3$
In case of IOH = 1.2 A, Vref = 1.2 x 0.33 x 3 = 1.19 V

STK672-050-E

$IOH = (1/3) \times Vref / Rs$, Rs: The hybrid IC internal current
detection resistor (0.2 Ω 3%)
 $Vref = Vcc2 (5.0 V) \times R02 / (R01 + R02) = IOH \times Rs \times 3$
In case of IOH = 2.0 A, Vref = 2.0 x 0.2 x 3 = 1.2 V

STK672-060-E

$IOH = (1/7.66) \times Vref / Rs$, Rs: The hybrid IC internal current
detection resistor (0.22 Ω 3%)
 $Vref = Vcc2 (5.0 V) \times R02 / (R01 + R02) = IOH \times Rs \times 7.66$
In case of IOH = 0.8 A, Vref = 0.8 x 0.22 x 7.66 = 1.35 V

ON Semiconductor and the ON Semiconductor logo are trademarks of Semiconductor Components Industries, LLC dba ON Semiconductor or its subsidiaries in the United States and/or other countries. ON Semiconductor owns the rights to a number of patents, trademarks, copyrights, trade secrets, and other intellectual property. A listing of ON Semiconductor's product/patent coverage may be accessed at www.onsemi.com/site/pdf/Patent-Marking.pdf. ON Semiconductor is an Equal Opportunity/Affirmative Action Employer. This literature is subject to all applicable copyright laws and is not for resale in any manner.

The evaluation board/kit (research and development board/kit) (hereinafter the "board") is not a finished product and is as such not available for sale to consumers. The board is only intended for research, development, demonstration and evaluation purposes and should as such only be used in laboratory/development areas by persons with an engineering/technical training and familiar with the risks associated with handling electrical/mechanical components, systems and subsystems. This person assumes full responsibility/liability for proper and safe handling. Any other use, resale or redistribution for any other purpose is strictly prohibited.

The board is delivered "AS IS" and without warranty of any kind including, but not limited to, that the board is production-worthy, that the functions contained in the board will meet your requirements, or that the operation of the board will be uninterrupted or error free. ON Semiconductor expressly disclaims all warranties, express, implied or otherwise, including without limitation, warranties of fitness for a particular purpose and non-infringement of intellectual property rights.

ON Semiconductor reserves the right to make changes without further notice to any board.

You are responsible for determining whether the board will be suitable for your intended use or application or will achieve your intended results. Prior to using or distributing any systems that have been evaluated, designed or tested using the board, you agree to test and validate your design to confirm the functionality for your application. Any technical, applications or design information or advice, quality characterization, reliability data or other services provided by ON Semiconductor shall not constitute any representation or warranty by ON Semiconductor, and no additional obligations or liabilities shall arise from ON Semiconductor having provided such information or services.

The boards are not designed, intended, or authorized for use in life support systems, or any FDA Class 3 medical devices or medical devices with a similar or equivalent classification in a foreign jurisdiction, or any devices intended for implantation in the human body. Should you purchase or use the board for any such unintended or unauthorized application, you shall indemnify and hold ON Semiconductor and its officers, employees, subsidiaries, affiliates, and distributors harmless against all claims, costs, damages, and expenses, and reasonable attorney fees arising out of, directly or indirectly, any claim of personal injury or death associated with such unintended or unauthorized use, even if such claim alleges that ON Semiconductor was negligent regarding the design or manufacture of the board.

This evaluation board/kit does not fall within the scope of the European Union directives regarding electromagnetic compatibility, restricted substances (RoHS), recycling (WEEE), FCC, CE or UL, and may not meet the technical requirements of these or other related directives.

FCC WARNING – This evaluation board/kit is intended for use for engineering development, demonstration, or evaluation purposes only and is not considered by ON Semiconductor to be a finished end product fit for general consumer use. It may generate, use, or radiate radio frequency energy and has not been tested for compliance with the limits of computing devices pursuant to part 15 of FCC rules, which are designed to provide reasonable protection against radio frequency interference. Operation of this equipment may cause interference with radio communications, in which case the user shall be responsible, at its expense, to take whatever measures may be required to correct this interference.

ON Semiconductor does not convey any license under its patent rights nor the rights of others.

LIMITATIONS OF LIABILITY: ON Semiconductor shall not be liable for any special, consequential, incidental, indirect or punitive damages, including, but not limited to the costs of requalification, delay, loss of profits or goodwill, arising out of or in connection with the board, even if ON Semiconductor is advised of the possibility of such damages. In no event shall ON Semiconductor's aggregate liability from any obligation arising out of or in connection with the board, under any theory of liability, exceed the purchase price paid for the board, if any.

For more information and documentation, please visit www.onsemi.com.

PUBLICATION ORDERING INFORMATION

LITERATURE FULFILLMENT:

Email Requests to: orderlit@onsemi.com

ON Semiconductor Website: www.onsemi.com

TECHNICAL SUPPORT

North American Technical Support:

Voice Mail: 1 800-282-9855 Toll Free USA/Canada

Phone: 011 421 33 790 2910

Europe, Middle East and Africa Technical Support:

Phone: 00421 33 790 2910

For additional information, please contact your local Sales Representative