

PART NUMBER	REV	FIRST USED	POWER UNIT	FEED TYPE	DESCRIPTION
1855115-1	B	122500-1	LEADMAKER	AIR FEED	CUTS CARRIER
1855115-2	B	565435-5	BENCH MODEL K	AIR FEED	CUTS CARRIER
1855115-3	B	354500-1	BENCH MODEL G	AIR FEED	CUTS CARRIER
1855115-6	B	122500-1	LEADMAKER	AIR FEED	CONTINUOUS CARRIER
7-1855115-7	A	-	-	-	SPARE PARTS

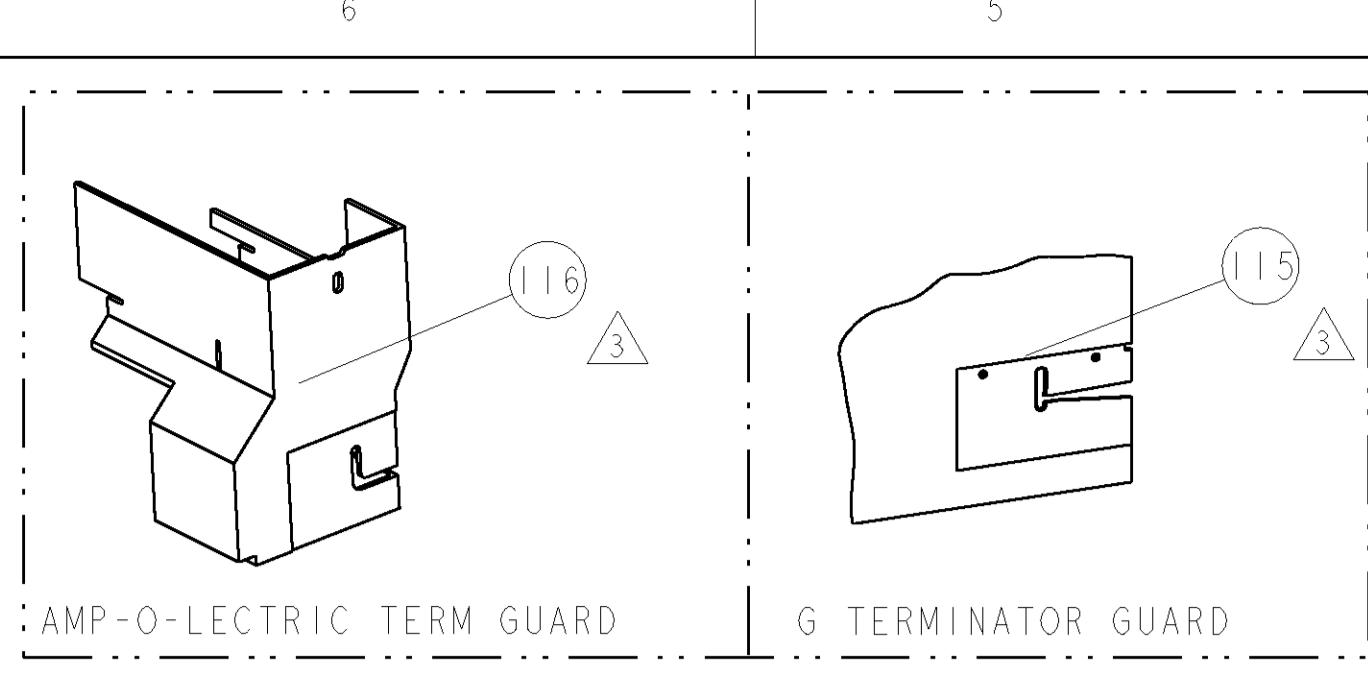

TYCO PN		MFG PN		FURUKAWA TERM - FURUKAWA CRIMP SPECS		REF SETTING
1949111	QLW-F-300			CRIMP HEIGHT	WIRE SIZE	C3
-	-	-	-	2.25±0.05mm [0.089±.002]	12AWG	
-	-	-	-	2.10±0.05mm [0.083±.002]	14AWG	D3
-	-	-	-	-	-	-
-	-	-	-	-	-	-
SEAL PN	SEAL PN	CRIMP	SIZE	TYPE	RANGE	
1949112	QLW-W-B200	WIRE	.135 [3.43mm]	F	14-12 AWG	
-	-	INSUL	.224 [5.69mm]	O	∅.220 MAX	
WIRE STRIP LENGTH	TERM APPL SPEC	FEED	APPLICATOR INSTRUCTIONS		SET UP GAGE	
.247 - .262	NONE	.807	408-8040		458637-1	

LOC	DIST	REV	DESCRIPTION	DATE	OWN	APPR
A	66					
		A	RELEASED	28SEP2006	MEH	GB
		B	ECR-08-027405	03NOV2008	DM	DM

- ▲ RECOMMENDED SPARE PARTS
- ▲ GREASE LIGHTLY
- ▲ GUARD MUST BE IN PLACE WHEN OPERATING APPLICATOR IN A BENCH MACHINE
- ▲ APPLY TORQ-SEAL IN ALLEN SOCKET TO FILL HOLE AFTER FLAT HD HAS BEEN ADJUSTED TO CORRECT HEIGHT AT QUALIFICATION. APPLY PN 1-23419-5 LOC-TITE TO THREADS.
- ▲ TRIM-TO-FIT ITEM 39 TO OUTSIDE DIA. OF ITEM 38 DURING ASSEMBLY

**\* WARNING**  
ON INSTALLATION, SET WIRE DISC TO LARGEST WIRE SIZE SETTING. USE OF SETTINGS BELOW MIN. REQUIRED CRIMP HEIGHT SETTING WILL CAUSE DAMAGE TO CRIMP TOOLING.

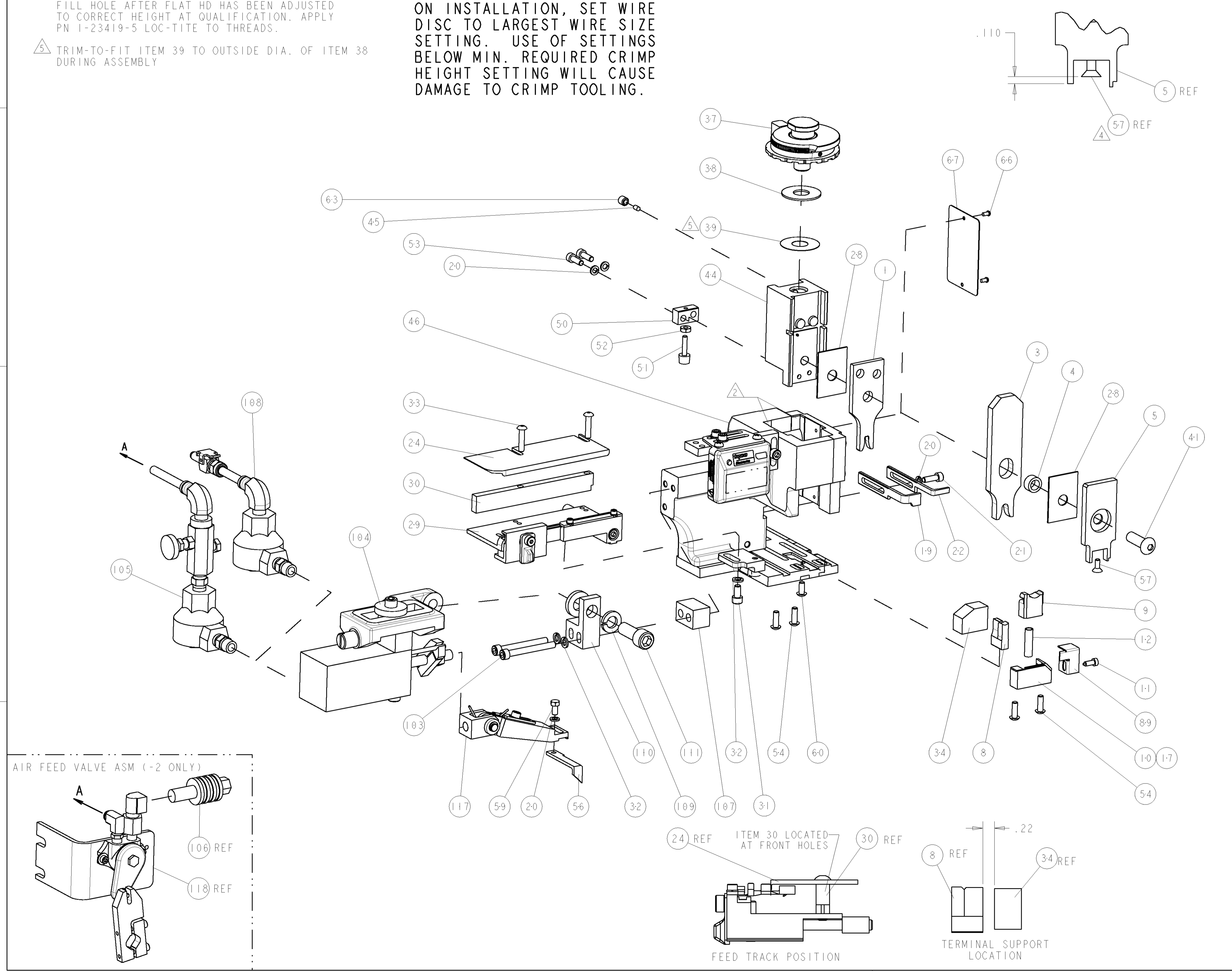

QTY	REF	PART NO	DESCRIPTION	ITEM NO
-	-	692655-6	AIR FEED VALVE ASSEMBLY	118
-	-	461062-1	FEED FINGER ASSEMBLY	117
-	-	455749-1	GUARD WINDOW	116
-	-	679532-1	INSERT, GUARD	115
-	-	3-21001-5	SCR, SKT HD CAP 3/8-16 X 1.000	111
-	-	459610-1	MOUNT, FEED BRACKET	110
-	-	21024-8	WASHER, SPRG LOCK, REG 3/8	109
-	-	692655-7	AIR FEED VALVE ASSEMBLY	108
-	-	461690-3	SPACER, AIR FEED	107
-	-	24024-2	VALVE, SHUT OFF	106
-	-	692655-5	AIR FEED VALVE ASSEMBLY	105
-	-	461065-1	ASSEMBLY, AIR FEED	104
-	-	4-21000-2	SCR, SKT HD CAP 10-32 X 1.750	103
-	-	318563-1	GUARD, FRONT CHIP	89
-	-	455888-8	SPACER, CRIMPER	82
-	-	4088040	SF APPL INST 408-8040	72
-	-	217238-1	GENERAL INSTRUCTION PKG	71
-	-	461264-5	PLATE, IDENTIFICATION	67
-	-	21017-2	SCREW, DRIVE	66
-	-	21009-2	SCR, SET, CUP POINT, SELF LOCKING 1/4-20 X .250	63
-	-	22733-8	SCR, BHSC, SELF-LOCKING, 8-32 X .375	60
-	-	2-22603-0	SCR, HEX HD CAP 8-32 X .312	59
-	-	1-21003-9	SCR, FLT SKT HD CAP 6-32 X .375	57
-	-	458537-2	PAWL, FEED	56
-	-	2-21002-2	SCR, BTN SKT HD CAP 8-32 X .500	54
-	-	2-21000-7	SCR, SKT HD CAP 8-32 X .500	53
-	-	21018-5	NUT, HEX, REG 6-32	52
-	-	811242-2	BUMPER, HOLD DOWN	51
-	-	690753-1	SPACER, TONKER	50
-	-	1633399-4	APPL., BASIC AIR FEED SUB ASSY	46
-	-	690191-1	PLUG, NYLON	45
-	-	2-819307-0	RAM, SIDE FEED	44
-	-	7-21002-9	SCR, BTN SKT HD CAP 5/16-24 X 1.00	41
-	-	690125-1	SHIM SUB-ASSY	39
-	-	1-469367-1	SHIM	38
-	-	879103-2	FINE ADJUST HEAD ASSEMBLY	37
-	-	3-690786-3	TERMINAL SUPPORT	34
-	-	2-21002-4	SCR, BTN SKT HD CAP 8-32 X .750	33
-	-	21024-5	WASHER, SPRG LOCK, REG NO 10	32
-	-	3-21000-4	SCR, SKT HD CAP 10-32 X .375	31
-	-	1320908-6	SPACER, STRIP GUIDE	30
-	-	1633091-7	ASSEMBLY, STRIP GUIDE	29
-	-	455888-8	SPACER, CRIMPER	28
-	-	1320928	PLATE, STRIP GUIDE	24
-	-	690472-2	STRIPPER	22
-	-	2-21000-7	SCR, SKT HD CAP 8-32 X .500	21
-	-	21024-4	WASHER, SPRG LOCK, REG NO 8	20
-	-	691353-1	STRIPPER	19
-	-	679625-4	SHEAR HOLDER, FRONT (NO CUT)	17
-	-	3-22280-3	SPRING, COMPRESSION	12
-	-	1-690461-7	STOP, SHEAR	11
-	-	2-690459-2	SHEAR HOLDER, FRONT	10
-	-	318059-4	FLOATING SHEAR, FRONT	9
-	-	8-1633116-3	ANVIL, COMBINATION	8
-	-	122399-4	DEPRESSOR, SHEAR	5
-	-	4-238011-9	BLOCK, CRIMPER SPACER	4
-	-	8-1583690-1	CRIMPER, INSUL O	3
-	-	3-1673600-7	CRIMPER, WIRE	1

QTY	REF	PART NO	DESCRIPTION	ITEM NO				
-77	-6	-3	-2	-1	U/M	PART NO	DESCRIPTION	ITEM NO

# Mouser Electronics

Authorized Distributor

Click to View Pricing, Inventory, Delivery & Lifecycle Information:

[TE Connectivity:](#)

[1855115-3](#)