

SPECIFICATION

- Part No. : **EMPCB.MMCXFSTJ.A.HT**
- Product Name : MMCX (F) Jack For Edge PCB Mount
- Feature : MMCX(F) Jack
Straight Edge Mount PCB Jack
Frequency Range: DC up to 6GHz
Finish: Gold
Leg Length: 2.9mm
Total Length: 7.4mm
RoHS Compliant



1. Introduction

The EMPCB.MMCXFSTJ.A.HT connector was designed to be mounted on a PCB edge. The edge mount configuration allows the connector to be easily slotted onto a PCB board; the maximum thickness of PCB that the connector can be used with is 0.8mm. The connector pin is directly soldered onto pads on the PCB. Taoglas connectors are all RoHS compliant.

2. Specification

ELECTRICAL	
Impedance	50Ω
Frequency Range	DC~6 GHz
Working Voltage	Max. ≤170 Vrms
Dielectric withstanding Voltage	500 Vrms
Insulation Resistance	≥1000M ohms
MECHANICAL	
Connector Dimension	7.4mm*Ø4.5 mm
Max. Thickness PCB acceptable	0.8mm
Connector Pin Diameter	0.7mm
Connector Type	MMCX(F) to PCB Edge Mounted
ENVIRONMENTAL	
RoHS compliant	

3. Connector Drawing

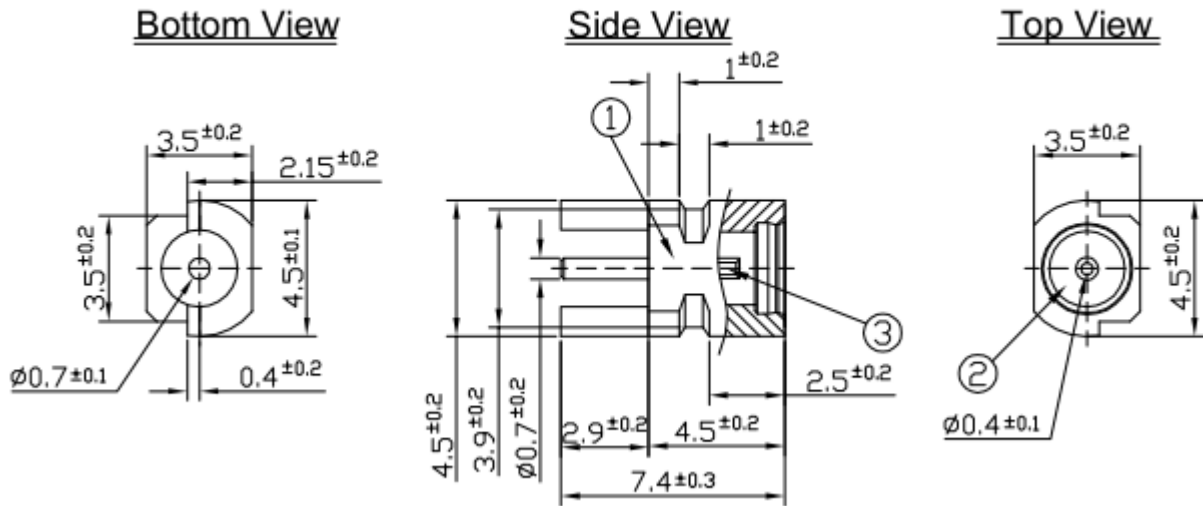

	Name	Material	Finish	QTY
1	Body	Brass	Gold	1
2	Insulator	Teflon	White	1
3	Female Contact	Phosphor Bronze	Gold	1

Mouser Electronics

Authorized Distributor

Click to View Pricing, Inventory, Delivery & Lifecycle Information:

Taoglas:

[EM.PCB.MMCX.F.ST.JACK.HT](#)