

TPL0501 256-Taps Single-Channel Digital Potentiometer With SPI Interface

1 Features

- Single-Channel, 256-Position Resolution
- 100-k Ω End-to-End Resistance Options
- Low Temperature Coefficient: 35 ppm/ $^{\circ}$ C
- SPI-Compatible Serial Interface
- 2.7-V to 5.5-V Single-Supply Operation
- \pm 20% Resistance Tolerance
- Operating Temperature: -40° C to 125° C
- ESD Performance Tested per JESD 22
 - 2000-V Human-Body Model (A114-B, Class II)

2 Applications

- Adjustable Power Supplies
- Adjustable Gain Amplifiers and Offset Trimming
- Precision Calibration of Set Point Thresholds
- Sensor Trimming and Calibration
- Mechanical Potentiometer Replacement

3 Description

The TPL0501 device is a single-channel, linear-taper digital potentiometer with 256 wiper positions. This device can be used as a three-terminal potentiometer or as a two-terminal rheostat. The TPL0501 device is currently offered with end-to-end resistance of 100 k Ω . The internal registers of the TPL0501 device can be accessed using a SPI-compatible interface. The TPL0501 device has a nominal temperature coefficient of 35 ppm/ $^{\circ}$ C.

The TPL0501 is available in an 8-pin SOT-23 and 8-pin UQFN package with a specified temperature range of -40° C to 85° C.

Device Information⁽¹⁾

PART NUMBER	PACKAGE	BODY SIZE (NOM)
TPL0501	UQFN (8)	1.50 mm x 1.50 mm
	SOT-23 (8)	1.63 mm x 2.90 mm

(1) For all available packages, see the orderable addendum at the end of the data sheet.

Simplified Schematic

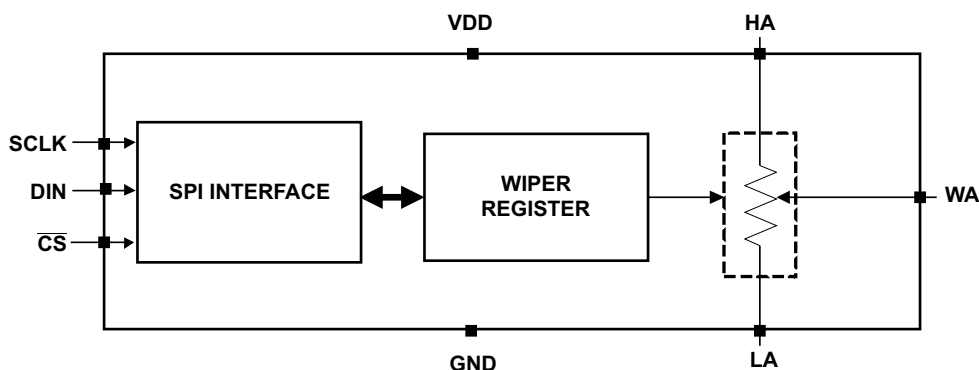

Copyright © 2016, Texas Instruments Incorporated



Table of Contents

1 Features	1	7.4 Device Functional Modes	8
2 Applications	1	7.5 Programming	11
3 Description	1	8 Application and Implementation	18
4 Revision History	2	8.1 Application Information	18
5 Pin Configuration and Functions	3	8.2 Typical Application	18
6 Specifications	3	9 Power Supply Recommendations	19
6.1 Absolute Maximum Ratings	3	9.1 Power Sequence	19
6.2 ESD Ratings	3	9.2 Wiper Position Upon Power Up	19
6.3 Thermal Information	4	10 Layout	20
6.4 Electrical Characteristics – Analog Specifications	4	10.1 Layout Guidelines	20
6.5 Electrical Characteristics – Operating Specifications	5	10.2 Layout Example	20
6.6 Timing Requirements	5	11 Device and Documentation Support	21
6.7 Typical Characteristics	6	11.1 Community Resources	21
7 Detailed Description	8	11.2 Trademarks	21
7.1 Overview	8	11.3 Electrostatic Discharge Caution	21
7.2 Functional Block Diagram	8	11.4 Glossary	21
7.3 Feature Description	8	12 Mechanical, Packaging, and Orderable Information	21

4 Revision History

Changes from Revision B (August 2012) to Revision C

Page

- Added *Device Information* table, *ESD Ratings* table, *Feature Description* section, *Device Functional Modes*, *Application and Implementation* section, *Power Supply Recommendations* section, *Layout* section, *Device and Documentation Support* section, and *Mechanical, Packaging, and Orderable Information* section..... **1**

5 Pin Configuration and Functions



Pin Functions

PIN			TYPE ⁽¹⁾	DESCRIPTION
NAME	SOT-23	UQFN		
CS	6	3	I	SPI chip select (active low)
DIN	5	2	I	SPI input
GND	3	4	G	Ground
H	8	1	I/O	High terminal
L	7	8	I/O	Low terminal
SCLK	4	5	I	SPI clock
V _{DD}	2	7	P	Positive supply voltage
W	1	6	I/O	Wiper terminal

(1) G = Ground, I = Input, O = Output, P = Power

6 Specifications

6.1 Absolute Maximum Ratings

over operating free-air temperature range (unless otherwise noted)⁽¹⁾⁽²⁾⁽³⁾

		MIN	MAX	UNIT
Supply voltage	V _{DD} to GND	-0.3	7	V
	V _H , V _L , V _W	-0.3	V _{DD} + 0.3	
Pulse current, I _H , I _L , I _W			±20	mA
Continuous current, I _H , I _L , I _W (TPL0501-100)			±5	mA
Digital input voltage, V _I		-0.3	7	V
Operating temperature, T _j			125	°C
Storage temperature, T _{stg}		-65	150	°C

- Stresses beyond those listed under *Absolute Maximum Ratings* may cause permanent damage to the device. These are stress ratings only, which do not imply functional operation of the device at these or any other conditions beyond those indicated under *Recommended Operating Conditions*. Exposure to absolute-maximum-rated conditions for extended periods may affect device reliability.
- The algebraic convention, whereby the most negative value is a minimum and the most positive value is a maximum
- All voltages are with respect to ground, unless otherwise specified.

6.2 ESD Ratings

		VALUE	UNIT
V _(ESD) Electrostatic discharge	Human-body model (HBM), per ANSI/ESDA/JEDEC JS-001 ⁽¹⁾	±2000	V
	Charged-device model (CDM), per JEDEC specification JESD22-C101 ⁽²⁾	±1000	

- JEDEC document JEP155 states that 500-V HBM allows safe manufacturing with a standard ESD control process.
- JEDEC document JEP157 states that 250-V CDM allows safe manufacturing with a standard ESD control process.

6.3 Thermal Information

THERMAL METRIC ⁽¹⁾		TPL0501		UNIT
		DCN (SOT-23)	RSE (UQFN)	
		8 PINS	8 PINS	
R _{θJA}	Junction-to-ambient thermal resistance ⁽²⁾	205.6	118.8	°C/W
R _{θJC(top)}	Junction-to-case (top) thermal resistance	122.3	62.4	°C/W
R _{θJB}	Junction-to-board thermal resistance	98.9	26.8	°C/W
ψ _{JT}	Junction-to-top characterization parameter	38.7	2.3	°C/W
ψ _{JB}	Junction-to-board characterization parameter	97.8	26.8	°C/W
R _{θJC(bot)}	Junction-to-case (bottom) thermal resistance	—	—	°C/W

(1) For more information about traditional and new thermal metrics, see the *Semiconductor and IC Package Thermal Metrics* application report, [SPRA953](#).

(2) The package thermal impedance is calculated in accordance with JESD 51-7.

6.4 Electrical Characteristics – Analog Specifications

Typical values are specified at V_{DD} = 5 V and operating temperature is 25°C (unless otherwise noted).

PARAMETER	TEST CONDITIONS	MIN	TYP	MAX	UNIT
R _{TOTAL}	End-to-end resistance	Between Hi and Li terminals			kΩ
V _H , V _L	Terminal voltage	0		V _{DD}	V
R _H , R _L	Terminal resistance		50	150	Ω
R _W	Wiper resistance	H terminal floating, V _L = GND, Force I _W = (V _{DD} /2) / R _{TOTAL} , input code = 0x80h			Ω
C _H , C _L	Terminal capacitance	f = 1 MHz, measured to GND, input code = 0x80h			pF
C _W	Wiper capacitance	f = 1 MHz, measured to GND, input code = 0x80h			pF
I _{LKG}	Terminal leakage current	V _H = GND to V _{DD} , V _L = floating or V _L = GND to V _{DD} , V _H = floating			μA
TC _R	Resistance temperature coefficient		35		ppm/°C
VOLTAGE DIVIDER MODE⁽¹⁾					
INL	Integral non-linearity	–1		1	LSB
DNL	Differential non-linearity	–0.5		0.5	LSB
Z _{ERROR}	Zero-scale error	0	0.5	2	LSB
F _{ERROR}	Full-scale error	–2	–0.5	0	LSB
T _{CV}	Ratiometric temperature coefficient	Wiper set at mid-scale			ppm/°C
BW	Bandwidth	Wiper set at mid-scale (TPL0501-100), C _{LOAD} = 10 pF			kHz
T _{SW}	Wiper settling time	TPL0501-100			μs
THD	Total harmonic distortion	V _H = 1 V _{RMS} at 1 kHz, V _L = V _{DD} /2, measurement at W			0.005%
RHEOSTAT MODE⁽²⁾					
RINL	Integral non-linearity	–1		1	LSB
RDNL	Differential non-linearity	–0.5		0.5	LSB
R _{OFFSET}	Offset	0	0.5	2	LSB
RBW	Bandwidth	Code = 0x00h, L floating, input applied to W, 10 pF on H			kHz

(1) V_H = V_{DD}, V_L = GND, V_W = not loaded

(2) Measurements between W_i and L_i with H_i not connected, or between W_i and H_i with L_i not connected.

6.5 Electrical Characteristics – Operating Specifications

Typical values are specified at V_{DD} = 5 V and operating temperature is 25°C (unless otherwise noted).

PARAMETER		TEST CONDITIONS	MIN	TYP	MAX	UNIT
I _{DD(STBY)}	V _{DD} standby current			0.3	8	μA
I _{IN-DIG}	Digital pins leakage current	SCLK, DIN, $\overline{\text{CS}}$ inputs	-1		1	μA
I _{DD(SUPPLY)}	V _{DD} supply current	Digital input = 1.8 V, V _{DD} = 2.7 V		5		μA
		Digital input = 1.8 V, V _{DD} = 5 V		500		
SERIAL INTERFACE⁽¹⁾						
V _{IH}	Input high voltage	V _{DD} = 2.7 V to 5.5 V	1.8		5.5	V
V _{IL}	Input low voltage	SCLK, DIN, $\overline{\text{CS}}$ inputs	0		0.6	V
C _{IN}	Pin capacitance	SCLK, DIN, $\overline{\text{CS}}$ inputs		7	10	pF

(1) SCLK, DIN, $\overline{\text{CS}}$ Inputs

6.6 Timing Requirements

		MIN	NOM	MAX	UNIT
f _{SCLK}	SCLK frequency			25	MHz
t _{SCP}	SCLK period	40			ns
t _{SCH}	SCLK high time	20			ns
t _{SCL}	SCLK low time	20			ns
t _{DS}	DIN to SCLK set-up time	5			ns
t _{DH}	DIN hold after SCLK	5			ns
t _{CSS}	$\overline{\text{CS}}$ fall to SCLK rise setup time	15			ns
t _{CSW}	$\overline{\text{CS}}$ pulse width high	40			ns

6.7 Typical Characteristics

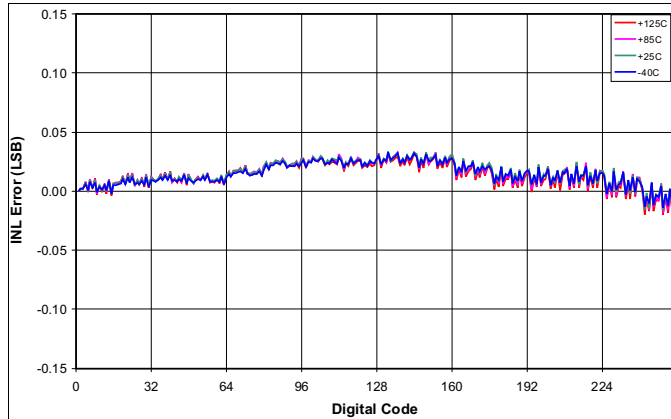

Figure 1. INL vs Tap Position (Potentiometer Mode)

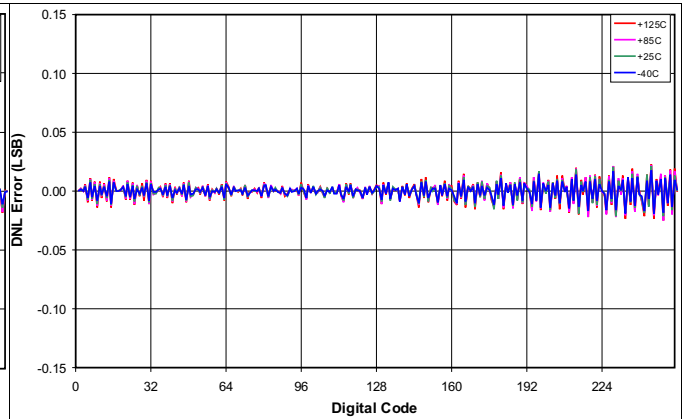

Figure 2. DNL vs Tap Position (Potentiometer Mode)

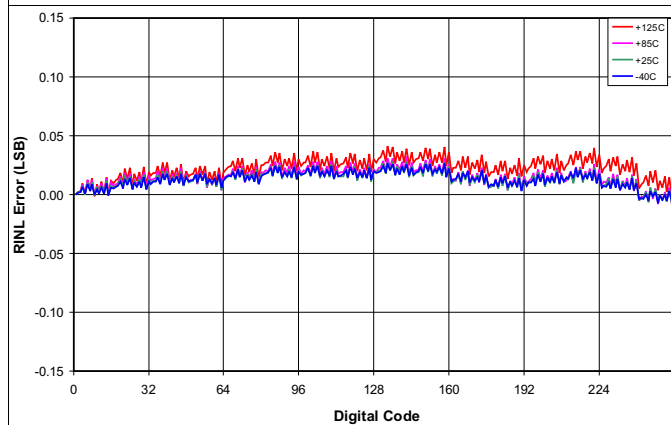

Figure 3. INL vs Tap Position (Rheostat Mode)

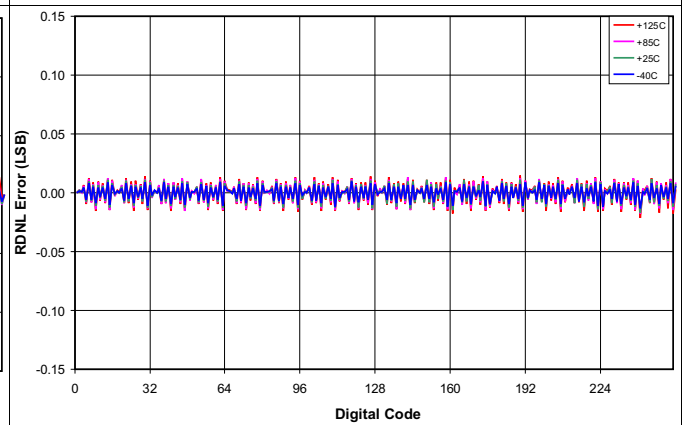

Figure 4. DNL vs Tap Position (Rheostat Mode)

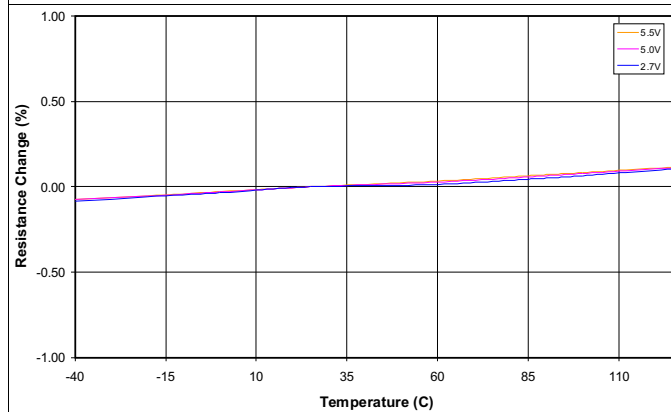

Figure 5. End-to-End Resistance Change vs Temperature

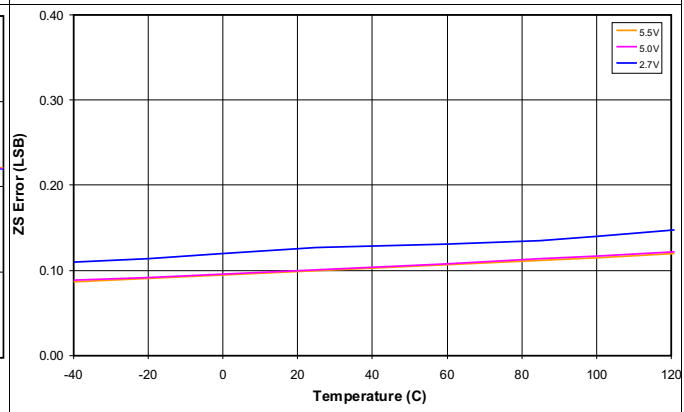

Figure 6. Zero Scale Error vs Temperature

Typical Characteristics (continued)

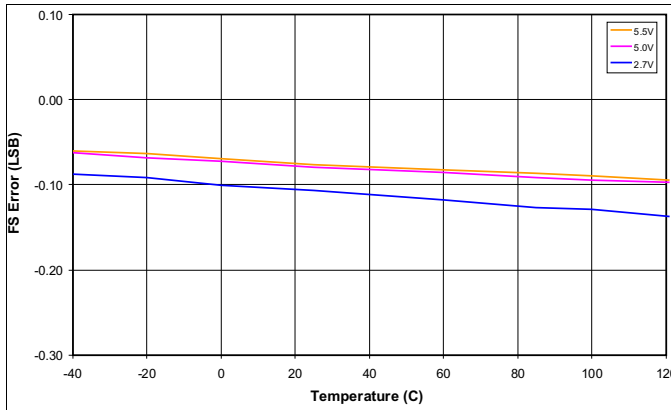

Figure 7. Full Scale Error vs Temperature

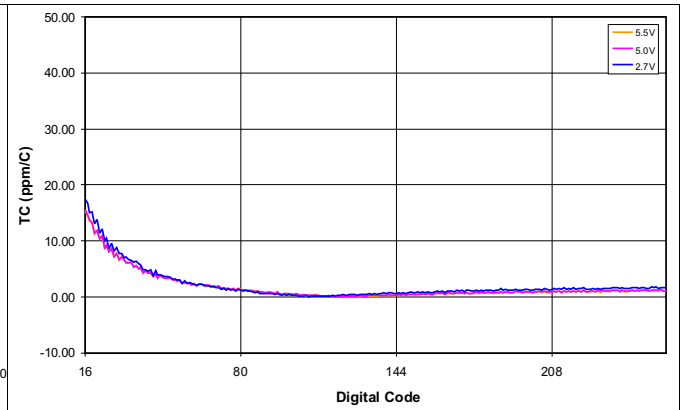

Figure 8. Temperature Coefficient vs Tap Position (Potentiometer Mode)

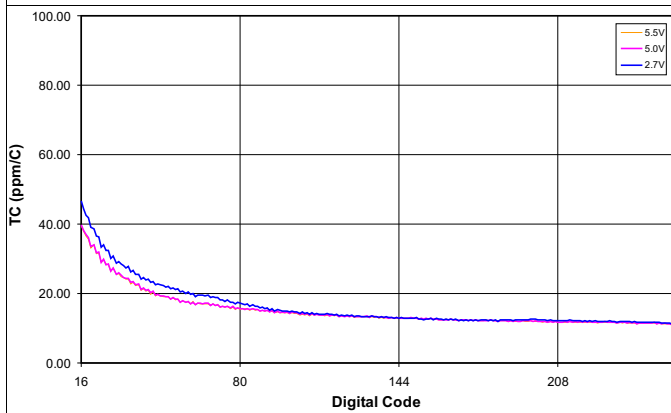

Figure 9. Temperature Coefficient vs Tap Position (Rheostat Mode)

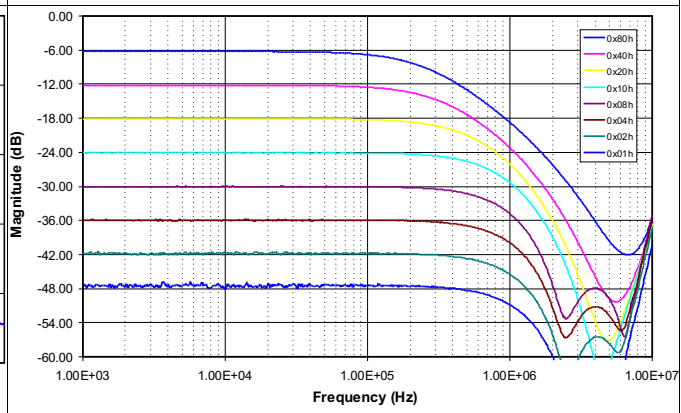

Figure 10. Bandwidth (Potentiometer Mode)

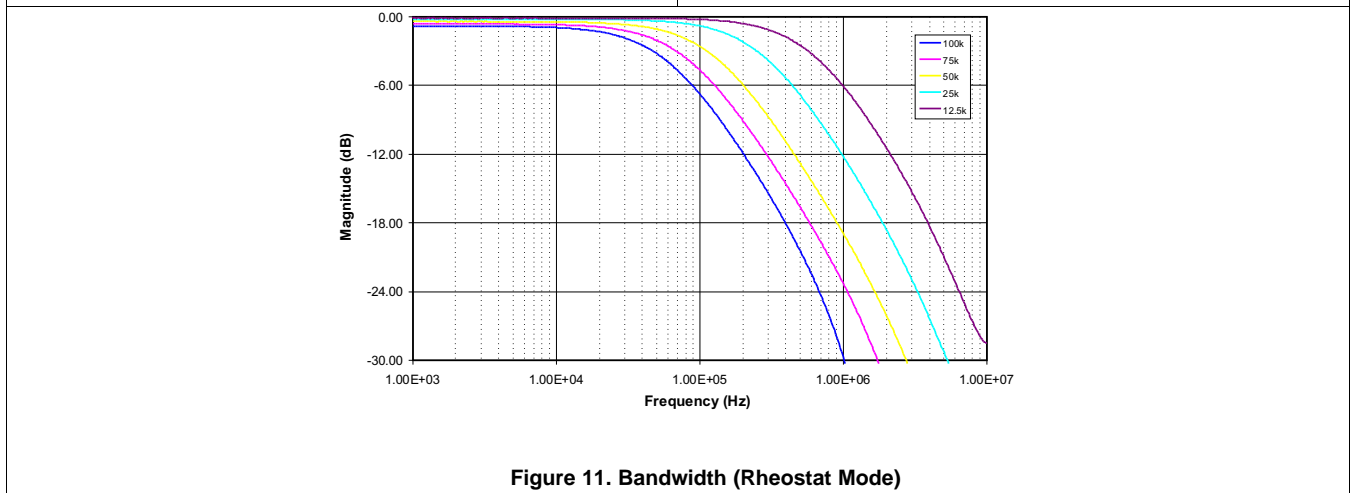

Figure 11. Bandwidth (Rheostat Mode)

7 Detailed Description

7.1 Overview

The TPL0501 has a single linear-taper digital potentiometer with 256 wiper positions and an end-to-end resistance of 100 k Ω . The potentiometer can be used as a three-terminal potentiometer or as a two-terminal rheostat. The potentiometer can be used in either voltage divider mode or rheostat mode.

The high (H) and low (L) terminals of the TPL0501 are equivalent to the fixed terminals of a mechanical potentiometer. The H and L terminals do not have any polarity restrictions (H can be at a higher voltage than L, or L can be at a higher voltage than H). The position of the wiper (W) terminal is controlled by the value in the 8-bit Wiper Resistance (WR) register. When the WR register contains all zeroes (zero-scale), the wiper terminal is closest to its L terminal. As the value of the WR register increases from all zeroes to all ones (full-scale), the wiper moves from the position closest to the L terminal, to the position closest to the H terminal. At the same time, the resistance between W and L increases, whereas the resistance between W and H decreases.

7.2 Functional Block Diagram

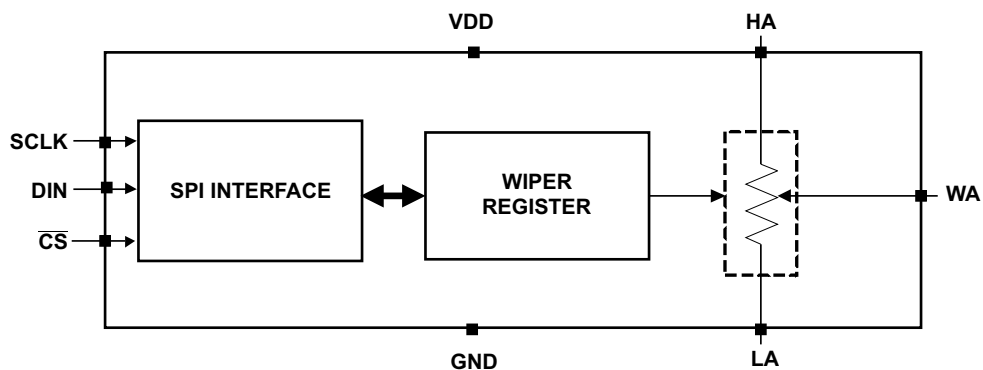

Copyright © 2016, Texas Instruments Incorporated

7.3 Feature Description

7.3.1 Single-Channel, 256-Position Resolution

The TPL0501 features a single independent DPOT. The DPOT is capable of being used and controlled independently.

7.4 Device Functional Modes

7.4.1 Voltage Divider Mode

The digital potentiometer generates a voltage divider when all three terminals are used. The voltage divider at wiper-to-H and wiper-to-L is proportional to the input voltage at H to L (see [Figure 12](#)).

Device Functional Modes (continued)

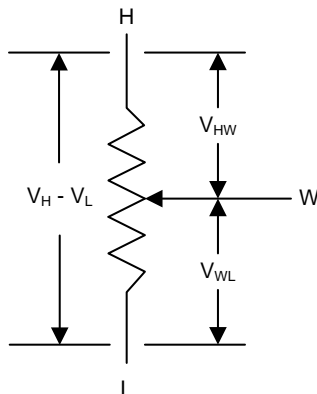

Figure 12. Equivalent Circuit for Voltage Divider Mode

For example, connecting terminal H to 5 V and terminal L to ground, the output voltage at terminal W can range from 0 V to 5 V (see Equation 1).

$$V_w = V_{wL} = (V_H - V_L) \times \frac{D}{256} \tag{1}$$

The voltage difference between terminal H and terminal W can also be calculated in Equation 2.

$$V_{HW} = (V_H - V_L) \times \left(1 - \left(\frac{D}{256} \right) \right)$$

where

- D is the decimal value of the wiper code. (2)

7.4.2 Rheostat Mode

The TPL0501 operates in rheostat mode when only two terminals are used as a variable resistor. The variable resistance can either be between terminal H and terminal W or between terminal L and terminal W. The unused terminal can be left floating or it can be tied to terminal W. The nominal resistance between terminal H and terminal L is 10 kΩ and has 256 tap points accessed by the wiper terminal. The 8-bit volatile register value is used to determine one of the 256 possible wiper positions.

To set the resistance between terminal H and terminal W in rheostat mode, the potentiometer can be configured in two possible ways (see Figure 13).

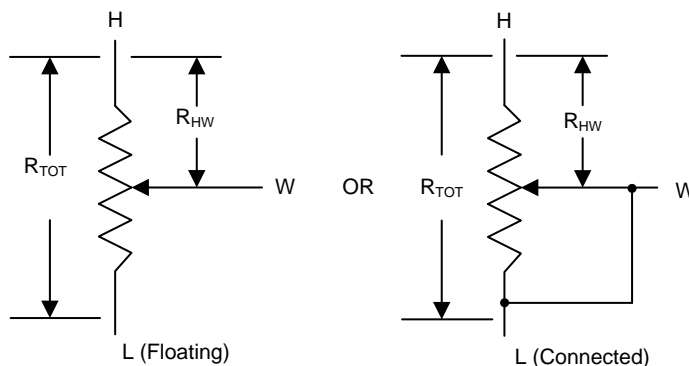

Figure 13. Equivalent Circuit for Rheostat Mode With Terminal H to Terminal W Resistance

The general equation for determining the digitally programmed output resistance between Terminal H and Terminal W is Equation 3:

Device Functional Modes (continued)

$$R_{HW} = R_{TOT} \times \left(1 - \left(\frac{D}{256} \right) \right)$$

where

- R_{TOT} is the end-to-end resistance between terminal H and terminal L.
 - D is the decimal value of the wiper code
- (3)

Similarly, to set the resistance between terminal L and terminal W, the potentiometer can be configured in two possible ways.

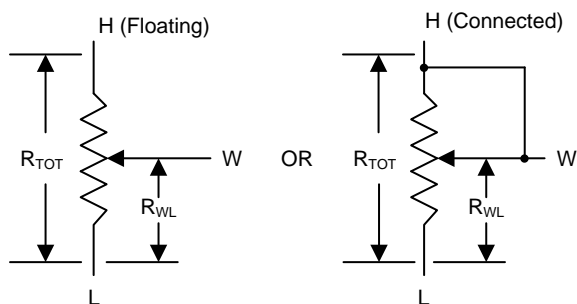

Figure 14. Equivalent Circuit for Rheostat Mode With Terminal L to Terminal W Resistance

The general equation for determining the digitally programmed output resistance between terminal L and terminal W is [Equation 4](#):

$$R_{WL} = R_{TOT} \times \frac{D}{256}$$

where

- R_{TOT} is the end-to-end resistance between terminal H and terminal L.
 - D is the decimal value of the wiper code.
- (4)

7.5 Programming

7.5.1 SPI Digital Interface

The TPL0501 uses a 3-wire SPI compatible serial data interface. This write-only interface has three inputs: chip-select (\overline{CS}), data clock (SCLK), and data input (DIN). Drive \overline{CS} low to enable the serial interface and clock data synchronously into the shift register on each SCLK rising edge. After loading data into the shift register, drive \overline{CS} high to latch the data into the appropriate potentiometer control register and disable the serial interface. Keep \overline{CS} low during the entire serial data stream to avoid corruption of the data.

Table 1. Default Value 0x80H

BIT7	BIT6	BIT5	BIT4	BIT3	BIT2	BIT1	BIT0
MSB							LSB
D7	D6	D5	D4	D3	D2	D1	D0

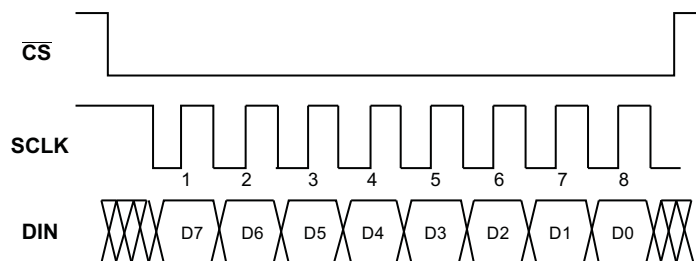

Figure 15. SPI Write Sequence

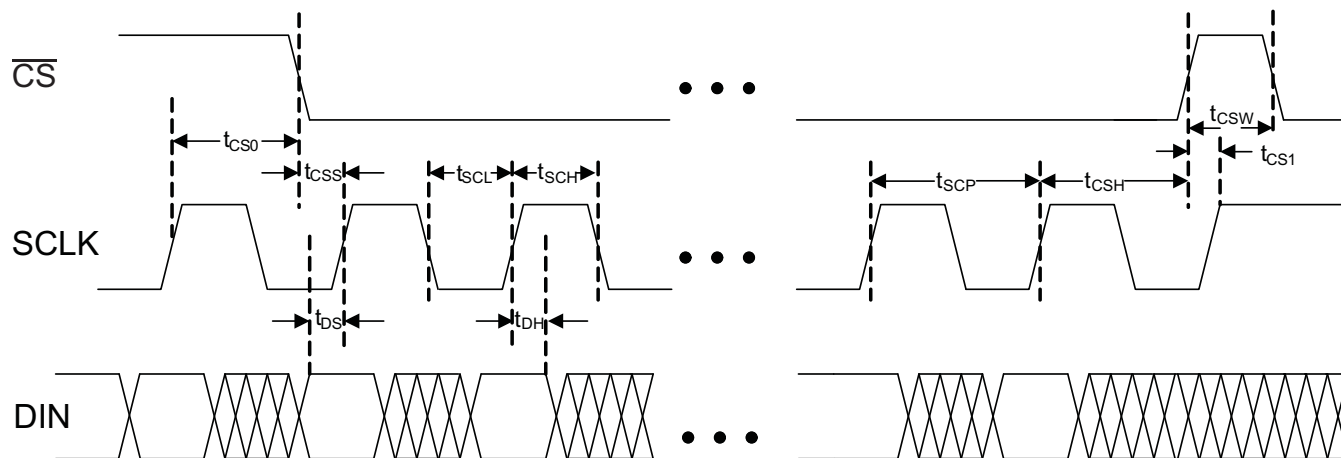

Figure 16. Digital Interface Timing Diagram

7.5.2 Ideal Resistance Values

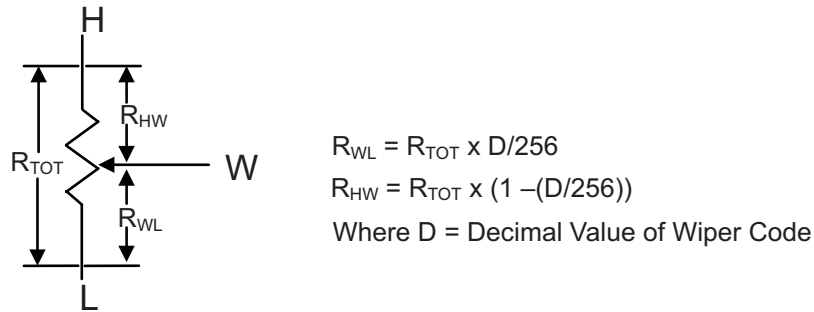

Figure 17. Digital Potentiometer Measurements

Table 2 shows the ideal values for DPOT with end-to-end resistance of 100 kΩ. The absolute values of resistance can vary significantly but the Ratio (R_{WL}/R_{HW}) is extremely accurate.

Table 2. DPOT Ideal Values

STEP	BINARY	100 kΩ		R_{WL}/R_{HW}
		R_{WL} (kΩ)	R_{HW} (kΩ)	
0	00000000	0.00	100.00	0.00
1	00000001	0.39	99.61	0.00
2	00000010	0.78	99.22	0.01
3	00000011	1.17	98.83	0.01
4	00000100	1.56	98.44	0.02
5	00000101	1.95	98.05	0.02
6	00000110	2.34	97.66	0.02
7	00000111	2.73	97.27	0.03
8	00001000	3.13	96.88	0.03
9	00001001	3.52	96.48	0.04
10	00001010	3.91	96.09	0.04
11	00001011	4.30	95.70	0.04
12	00001100	4.69	95.31	0.05
13	00001101	5.08	94.92	0.05
14	00001110	5.47	94.53	0.06
15	00001111	5.86	94.14	0.06
16	00010000	6.25	93.75	0.07
17	00010001	6.64	93.36	0.07
18	00010010	7.03	92.97	0.08
19	00010011	7.42	92.58	0.08
20	00010100	7.81	92.19	0.08
21	00010101	8.20	91.80	0.09
22	00010110	8.59	91.41	0.09
23	00010111	8.98	91.02	0.10
24	00011000	9.38	90.63	0.10
25	00011001	9.77	90.23	0.11
26	00011010	10.16	89.84	0.11
27	00011011	10.55	89.45	0.12
28	00011100	10.94	89.06	0.12
29	00011101	11.33	88.67	0.13
30	00011110	11.72	88.28	0.13

Table 2. DPOT Ideal Values (continued)

STEP	BINARY	100 k Ω		R _{WL} /R _{HW}
		R _{WL} (k Ω)	R _{HW} (k Ω)	
31	00011111	12.11	87.89	0.14
32	00100000	12.50	87.50	0.14
33	00100001	12.89	87.11	0.15
34	00100010	13.28	86.72	0.15
35	00100011	13.67	86.33	0.16
36	00100100	14.06	85.94	0.16
37	00100101	14.45	85.55	0.17
38	00100110	14.84	85.16	0.17
39	00100111	15.23	84.77	0.18
40	00101000	15.63	84.38	0.19
41	00101001	16.02	83.98	0.19
42	00101010	16.41	83.59	0.20
43	00101011	16.80	83.20	0.20
44	00101100	17.19	82.81	0.21
45	00101101	17.58	82.42	0.21
46	00101110	17.97	82.03	0.22
47	00101111	18.36	81.64	0.22
48	00110000	18.75	81.25	0.23
49	00110001	19.14	80.86	0.24
50	00110010	19.53	80.47	0.24
51	00110011	19.92	80.08	0.25
52	00110100	20.31	79.69	0.25
53	00110101	20.70	79.30	0.26
54	00110110	21.09	78.91	0.27
55	00110111	21.48	78.52	0.27
56	00111000	21.88	78.13	0.28
57	00111001	22.27	77.73	0.29
58	00111010	22.66	77.34	0.29
59	00111011	23.05	76.95	0.30
60	00111100	23.44	76.56	0.31
61	00111101	23.83	76.17	0.31
62	00111110	24.22	75.78	0.32
63	00111111	24.61	75.39	0.33
64	01000000	25.00	75.00	0.33
65	01000001	25.39	74.61	0.34
66	01000010	25.78	74.22	0.35
67	01000011	26.17	73.83	0.35
68	01000100	26.56	73.44	0.36
69	01000101	26.95	73.05	0.37
70	01000110	27.34	72.66	0.38
71	01000111	27.73	72.27	0.38
72	01001000	28.13	71.88	0.39
73	01001001	28.52	71.48	0.40
74	01001010	28.91	71.09	0.41
75	01001011	29.30	70.70	0.41
76	01001100	29.69	70.31	0.42

Table 2. DPOT Ideal Values (continued)

STEP	BINARY	100 k Ω		R _{WL} /R _{HW}
		R _{WL} (k Ω)	R _{HW} (k Ω)	
77	01001101	30.08	69.92	0.43
78	01001110	30.47	69.53	0.44
79	01001111	30.86	69.14	0.45
80	01010000	31.25	68.75	0.45
81	01010001	31.64	68.36	0.46
82	01010010	32.03	67.97	0.47
83	01010011	32.42	67.58	0.48
84	01010100	32.81	67.19	0.49
85	01010101	33.20	66.80	0.50
86	01010110	33.59	66.41	0.51
87	01010111	33.98	66.02	0.51
88	01011000	34.38	65.63	0.52
89	01011001	34.77	65.23	0.53
90	01011010	35.16	64.84	0.54
91	01011011	35.55	64.45	0.55
92	01011100	35.94	64.06	0.56
93	01011101	36.33	63.67	0.57
94	01011110	36.72	63.28	0.58
95	01011111	37.11	62.89	0.59
96	01100000	37.50	62.50	0.60
97	01100001	37.89	62.11	0.61
98	01100010	38.28	61.72	0.62
99	01100011	38.67	61.33	0.63
100	01100100	39.06	60.94	0.64
101	01100101	39.45	60.55	0.65
102	01100110	39.84	60.16	0.66
103	01100111	40.23	59.77	0.67
104	01101000	40.63	59.38	0.68
105	01101001	41.02	58.98	0.70
106	01101010	41.41	58.59	0.71
107	01101011	41.80	58.20	0.72
108	01101100	42.19	57.81	0.73
109	01101101	42.58	57.42	0.74
110	01101110	42.97	57.03	0.75
111	01101111	43.36	56.64	0.77
112	01110000	43.75	56.25	0.78
113	01110001	44.14	55.86	0.79
114	01110010	44.53	55.47	0.80
115	01110011	44.92	55.08	0.82
116	01110100	45.31	54.69	0.83
117	01110101	45.70	54.30	0.84
118	01110110	46.09	53.91	0.86
119	01110111	46.48	53.52	0.87
120	01111000	46.88	53.13	0.88
121	01111001	47.27	52.73	0.90
122	01111010	47.66	52.34	0.91

Table 2. DPOT Ideal Values (continued)

STEP	BINARY	100 k Ω		R _{WL} /R _{HW}
		R _{WL} (k Ω)	R _{HW} (k Ω)	
123	01111011	48.05	51.95	0.92
124	01111100	48.44	51.56	0.94
125	01111101	48.83	51.17	0.95
126	01111110	49.22	50.78	0.97
127	01111111	49.61	50.39	0.98
128	10000000	50.00	50.00	1.00
129	10000001	50.39	49.61	1.02
130	10000010	50.78	49.22	1.03
131	10000011	51.17	48.83	1.05
132	10000100	51.56	48.44	1.06
133	10000101	51.95	48.05	1.08
134	10000110	52.34	47.66	1.10
135	10000111	52.73	47.27	1.12
136	10001000	53.13	46.88	1.13
137	10001001	53.52	46.48	1.15
138	10001010	53.91	46.09	1.17
139	10001011	54.30	45.70	1.19
140	10001100	54.69	45.31	1.21
141	10001101	55.08	44.92	1.23
142	10001110	55.47	44.53	1.25
143	10001111	55.86	44.14	1.27
144	10010000	56.25	43.75	1.29
145	10010001	56.64	43.36	1.31
146	10010010	57.03	42.97	1.33
147	10010011	57.42	42.58	1.35
148	10010100	57.81	42.19	1.37
149	10010101	58.20	41.80	1.39
150	10010110	58.59	41.41	1.42
151	10010111	58.98	41.02	1.44
152	10011000	59.38	40.63	1.46
153	10011001	59.77	40.23	1.49
154	10011010	60.16	39.84	1.51
155	10011011	60.55	39.45	1.53
156	10011100	60.94	39.06	1.56
157	10011101	61.33	38.67	1.59
158	10011110	61.72	38.28	1.61
159	10011111	62.11	37.89	1.64
160	10100000	62.50	37.50	1.67
161	10100001	62.89	37.11	1.69
162	10100010	63.28	36.72	1.72
163	10100011	63.67	36.33	1.75
164	10100100	64.06	35.94	1.78
165	10100101	64.45	35.55	1.81
166	10100110	64.84	35.16	1.84
167	10100111	65.23	34.77	1.88
168	10101000	65.63	34.38	1.91

Table 2. DPOT Ideal Values (continued)

STEP	BINARY	100 k Ω		R _{WL} /R _{HW}
		R _{WL} (k Ω)	R _{HW} (k Ω)	
169	10101001	66.02	33.98	1.94
170	10101010	66.41	33.59	1.98
171	10101011	66.80	33.20	2.01
172	10101100	67.19	32.81	2.05
173	10101101	67.58	32.42	2.08
174	10101110	67.97	32.03	2.12
175	10101111	68.36	31.64	2.16
176	10110000	68.75	31.25	2.20
177	10110001	69.14	30.86	2.24
178	10110010	69.53	30.47	2.28
179	10110011	69.92	30.08	2.32
180	10110100	70.31	29.69	2.37
181	10110101	70.70	29.30	2.41
182	10110110	71.09	28.91	2.46
183	10110111	71.48	28.52	2.51
184	10111000	71.88	28.13	2.56
185	10111001	72.27	27.73	2.61
186	10111010	72.66	27.34	2.66
187	10111011	73.05	26.95	2.71
188	10111100	73.44	26.56	2.76
189	10111101	73.83	26.17	2.82
190	10111110	74.22	25.78	2.88
191	10111111	74.61	25.39	2.94
192	11000000	75.00	25.00	3.00
193	11000001	75.39	24.61	3.06
194	11000010	75.78	24.22	3.13
195	11000011	76.17	23.83	3.20
196	11000100	76.56	23.44	3.27
197	11000101	76.95	23.05	3.34
198	11000110	77.34	22.66	3.41
199	11000111	77.73	22.27	3.49
200	11001000	78.13	21.88	3.57
201	11001001	78.52	21.48	3.65
202	11001010	78.91	21.09	3.74
203	11001011	79.30	20.70	3.83
204	11001100	79.69	20.31	3.92
205	11001101	80.08	19.92	4.02
206	11001110	80.47	19.53	4.12
207	11001111	80.86	19.14	4.22
208	11010000	81.25	18.75	4.33
209	11010001	81.64	18.36	4.45
210	11010010	82.03	17.97	4.57
211	11010011	82.42	17.58	4.69
212	11010100	82.81	17.19	4.82
213	11010101	83.20	16.80	4.95
214	11010110	83.59	16.41	5.10

Table 2. DPOT Ideal Values (continued)

STEP	BINARY	100 k Ω		R _{WL} /R _{HW}
		R _{WL} (k Ω)	R _{HW} (k Ω)	
215	11010111	83.98	16.02	5.24
216	11011000	84.38	15.63	5.40
217	11011001	84.77	15.23	5.56
218	11011010	85.16	14.84	5.74
219	11011011	85.55	14.45	5.92
220	11011100	85.94	14.06	6.11
221	11011101	86.33	13.67	6.31
222	11011110	86.72	13.28	6.53
223	11011111	87.11	12.89	6.76
224	11100000	87.50	12.50	7.00
225	11100001	87.89	12.11	7.26
226	11100010	88.28	11.72	7.53
227	11100011	88.67	11.33	7.83
228	11100100	89.06	10.94	8.14
229	11100101	89.45	10.55	8.48
230	11100110	89.84	10.16	8.85
231	11100111	90.23	9.77	9.24
232	11101000	90.63	9.38	9.67
233	11101001	91.02	8.98	10.13
234	11101010	91.41	8.59	10.64
235	11101011	91.80	8.20	11.19
236	11101100	92.19	7.81	11.80
237	11101101	92.58	7.42	12.47
238	11101110	92.97	7.03	13.22
239	11101111	93.36	6.64	14.06
240	11110000	93.75	6.25	15.00
241	11110001	94.14	5.86	16.07
242	11110010	94.53	5.47	17.29
243	11110011	94.92	5.08	18.69
244	11110100	95.31	4.69	20.33
245	11110101	95.70	4.30	22.27
246	11110110	96.09	3.91	24.60
247	11110111	96.48	3.52	27.44
248	11111000	96.88	3.13	31.00
249	11111001	97.27	2.73	35.57
250	11111010	97.66	2.34	41.67
251	11111011	98.05	1.95	50.20
252	11111100	98.44	1.56	63.00
253	11111101	98.83	1.17	84.33
254	11111110	99.22	0.78	127.00
255	11111111	99.61	0.39	255.00

8 Application and Implementation

NOTE

Information in the following applications sections is not part of the TI component specification, and TI does not warrant its accuracy or completeness. TI's customers are responsible for determining suitability of components for their purposes. Customers should validate and test their design implementation to confirm system functionality.

8.1 Application Information

Many applications require using a digital potentiometer such as the TPL0501 for variable resistance or voltage division. *Typical Application* shows one of these examples. In conjunction with various amplifiers, the TPL0501 can effectively be used in rheostat mode to modify the gain of an amplifier in voltage divider mode to create a digital-to-analog converter (DAC).

8.2 Typical Application

Figure 18 shows a DAC.

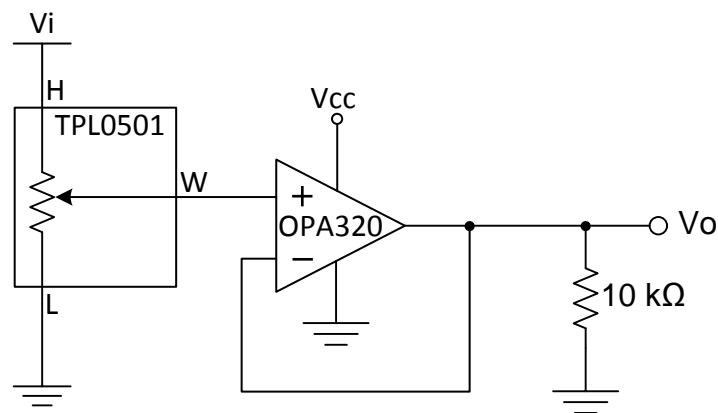

Copyright © 2016, Texas Instruments Incorporated

Figure 18. DAC Schematic

8.2.1 Design Requirements

Table 3 lists the design parameters for this application.

Table 3. Example Parameters

DESIGN PARAMETER	EXAMPLE VALUE
Input voltage	0 V to 5 V
Output voltage	0 V to 5 V

8.2.2 Detailed Design Procedure

The TPL0501 can be used in voltage divider mode with a unity-gain operational amplifier buffer to create an 8-bit DAC. The analog output voltage of the circuit is determined by the wiper setting programmed through the SPI Interface.

The operational amplifier is required to buffer the high-impedance output of the TPL0501 or else loading placed on the output of the voltage divider affects the output voltage.

8.2.3 Application Curve

The voltage at terminal H determines the maximum analog voltage at the output. As the TPL0501 moves from zero-scale to full-scale, the voltage divider adjusts with relation to the voltage divider formula (see Figure 12), resulting in the desired voltage at terminal W. The voltage at terminal W ranges linearly from 0 V to the terminal H voltage. In this example, V_{IN} at terminal H is 5 V and 2.7 V.

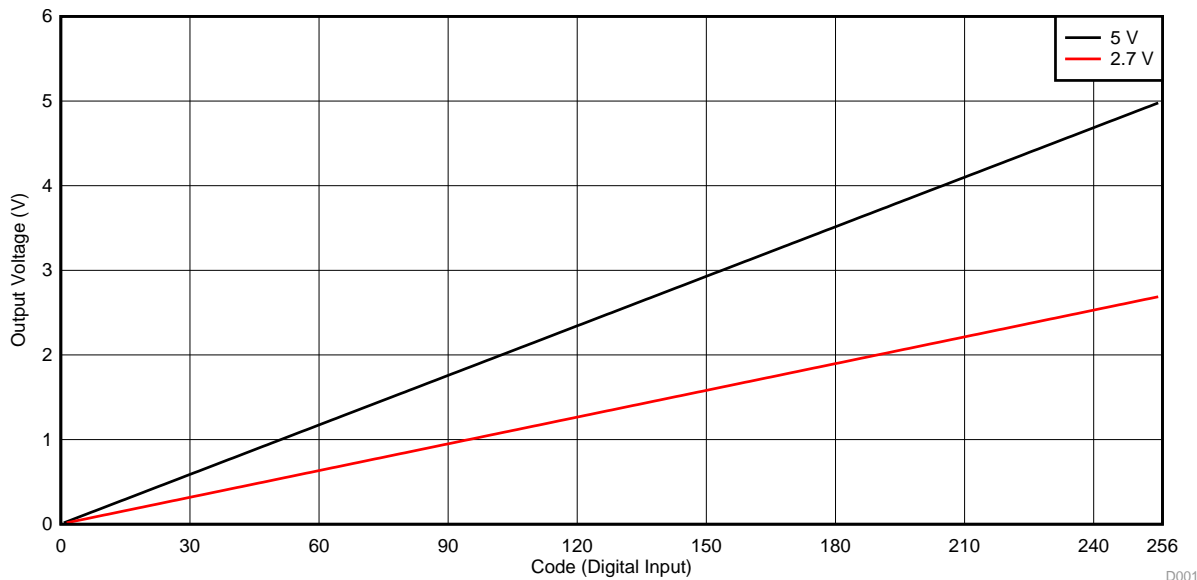

Figure 19. TPL0501 Digital Input vs OPA320 Analog Output (DAC)

9 Power Supply Recommendations

9.1 Power Sequence

Protection diodes limit the voltage compliance at terminal H, terminal L, and terminal W, making it important to power up V_{DD} first before applying any voltage to terminal H, terminal L, and terminal W. The diodes are forward-biasing, meaning V_{DD} is not powered first. The ideal power up sequence is V_{DD} , digital inputs, and V_H , V_L , and V_W . The order of powering digital inputs, V_H , V_L , and V_W does not matter as long as they are powered after V_{DD} .

9.2 Wiper Position Upon Power Up

It is prudent to know that when DPOT is powered off, the impedance of the device is not known. Upon power up, the device will return to 0x80h code because this device does not contain non-volatile memory.

10 Layout

10.1 Layout Guidelines

To ensure reliability of the device, follow common printed-circuit board (PCB) layout guidelines.

- Leads to the input must be as direct as possible with a minimum conductor length.
- The ground path must have low resistance and low inductance.
- Use short trace-lengths to avoid excessive loading.
- It is common to have a dedicated ground plane on an inner layer of the board.
- Terminals that are connected to ground must have a low-impedance path to the ground plane in the form of wide polygon pours and multiple vias.
- Use bypass capacitors on power supplies and placed them as close as possible to the V_{DD} pin.
- Apply low equivalent series resistance ($0.1\text{-}\mu\text{F}$ to $10\text{-}\mu\text{F}$ tantalum or electrolytic capacitors) at the supplies to minimize transient disturbances and to filter low frequency ripple.

10.2 Layout Example

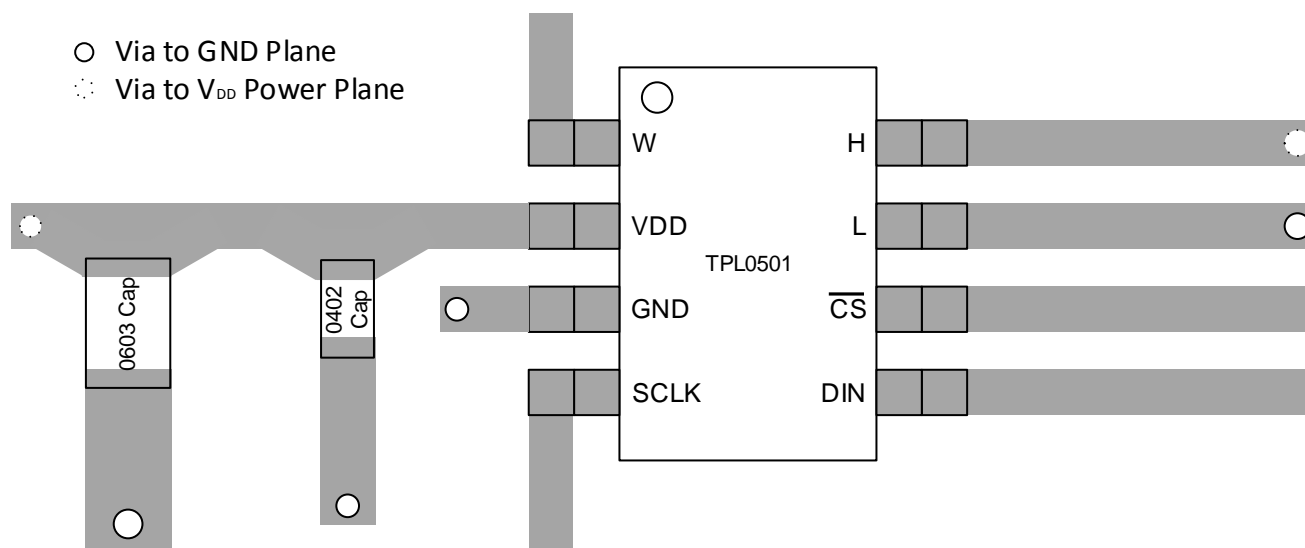

Figure 20. Example Layout for DCN Package

11 Device and Documentation Support

11.1 Community Resources

The following links connect to TI community resources. Linked contents are provided "AS IS" by the respective contributors. They do not constitute TI specifications and do not necessarily reflect TI's views; see TI's [Terms of Use](#).

TI E2E™ Online Community *TI's Engineer-to-Engineer (E2E) Community*. Created to foster collaboration among engineers. At e2e.ti.com, you can ask questions, share knowledge, explore ideas and help solve problems with fellow engineers.

Design Support *TI's Design Support* Quickly find helpful E2E forums along with design support tools and contact information for technical support.

11.2 Trademarks

E2E is a trademark of Texas Instruments.
All other trademarks are the property of their respective owners.

11.3 Electrostatic Discharge Caution



These devices have limited built-in ESD protection. The leads should be shorted together or the device placed in conductive foam during storage or handling to prevent electrostatic damage to the MOS gates.

11.4 Glossary

[SLYZ022](#) — *TI Glossary*.

This glossary lists and explains terms, acronyms, and definitions.

12 Mechanical, Packaging, and Orderable Information

The following pages include mechanical, packaging, and orderable information. This information is the most current data available for the designated devices. This data is subject to change without notice and revision of this document. For browser-based versions of this data sheet, refer to the left-hand navigation.

PACKAGING INFORMATION

Orderable Device	Status (1)	Package Type	Package Drawing	Pins	Package Qty	Eco Plan (2)	Lead/Ball Finish (6)	MSL Peak Temp (3)	Op Temp (°C)	Device Marking (4/5)	Samples
TPL0501-100DCNR	ACTIVE	SOT-23	DCN	8	3000	Green (RoHS & no Sb/Br)	CU NIPDAU	Level-1-260C-UNLIM	-40 to 125	(NF5J ~ NF5T)	Samples
TPL0501-100RSER	ACTIVE	UQFN	RSE	8	5000	Green (RoHS & no Sb/Br)	CU NIPDAUAG	Level-1-260C-UNLIM	-40 to 125	7M	Samples

(1) The marketing status values are defined as follows:

ACTIVE: Product device recommended for new designs.

LIFEBUY: TI has announced that the device will be discontinued, and a lifetime-buy period is in effect.

NRND: Not recommended for new designs. Device is in production to support existing customers, but TI does not recommend using this part in a new design.

PREVIEW: Device has been announced but is not in production. Samples may or may not be available.

OBSOLETE: TI has discontinued the production of the device.

(2) Eco Plan - The planned eco-friendly classification: Pb-Free (RoHS), Pb-Free (RoHS Exempt), or Green (RoHS & no Sb/Br) - please check <http://www.ti.com/productcontent> for the latest availability information and additional product content details.

TBD: The Pb-Free/Green conversion plan has not been defined.

Pb-Free (RoHS): TI's terms "Lead-Free" or "Pb-Free" mean semiconductor products that are compatible with the current RoHS requirements for all 6 substances, including the requirement that lead not exceed 0.1% by weight in homogeneous materials. Where designed to be soldered at high temperatures, TI Pb-Free products are suitable for use in specified lead-free processes.

Pb-Free (RoHS Exempt): This component has a RoHS exemption for either 1) lead-based flip-chip solder bumps used between the die and package, or 2) lead-based die adhesive used between the die and leadframe. The component is otherwise considered Pb-Free (RoHS compatible) as defined above.

Green (RoHS & no Sb/Br): TI defines "Green" to mean Pb-Free (RoHS compatible), and free of Bromine (Br) and Antimony (Sb) based flame retardants (Br or Sb do not exceed 0.1% by weight in homogeneous material)

(3) MSL, Peak Temp. - The Moisture Sensitivity Level rating according to the JEDEC industry standard classifications, and peak solder temperature.

(4) There may be additional marking, which relates to the logo, the lot trace code information, or the environmental category on the device.

(5) Multiple Device Markings will be inside parentheses. Only one Device Marking contained in parentheses and separated by a "~" will appear on a device. If a line is indented then it is a continuation of the previous line and the two combined represent the entire Device Marking for that device.

(6) Lead/Ball Finish - Orderable Devices may have multiple material finish options. Finish options are separated by a vertical ruled line. Lead/Ball Finish values may wrap to two lines if the finish value exceeds the maximum column width.

Important Information and Disclaimer: The information provided on this page represents TI's knowledge and belief as of the date that it is provided. TI bases its knowledge and belief on information provided by third parties, and makes no representation or warranty as to the accuracy of such information. Efforts are underway to better integrate information from third parties. TI has taken and continues to take reasonable steps to provide representative and accurate information but may not have conducted destructive testing or chemical analysis on incoming materials and chemicals. TI and TI suppliers consider certain information to be proprietary, and thus CAS numbers and other limited information may not be available for release.

In no event shall TI's liability arising out of such information exceed the total purchase price of the TI part(s) at issue in this document sold by TI to Customer on an annual basis.

TAPE AND REEL INFORMATION



QUADRANT ASSIGNMENTS FOR PIN 1 ORIENTATION IN TAPE



*All dimensions are nominal

Device	Package Type	Package Drawing	Pins	SPQ	Reel Diameter (mm)	Reel Width W1 (mm)	A0 (mm)	B0 (mm)	K0 (mm)	P1 (mm)	W (mm)	Pin1 Quadrant
TPL0501-100DCNR	SOT-23	DCN	8	3000	180.0	8.4	3.23	3.17	1.37	4.0	8.0	Q3
TPL0501-100RSER	UQFN	RSE	8	5000	180.0	8.4	1.7	1.7	0.7	4.0	8.0	Q1

TAPE AND REEL BOX DIMENSIONS

*All dimensions are nominal

Device	Package Type	Package Drawing	Pins	SPQ	Length (mm)	Width (mm)	Height (mm)
TPL0501-100DCNR	SOT-23	DCN	8	3000	202.0	201.0	28.0
TPL0501-100RSER	UQFN	RSE	8	5000	202.0	201.0	28.0

DCN (R-PDSO-G8)

PLASTIC SMALL-OUTLINE PACKAGE (DIE DOWN)

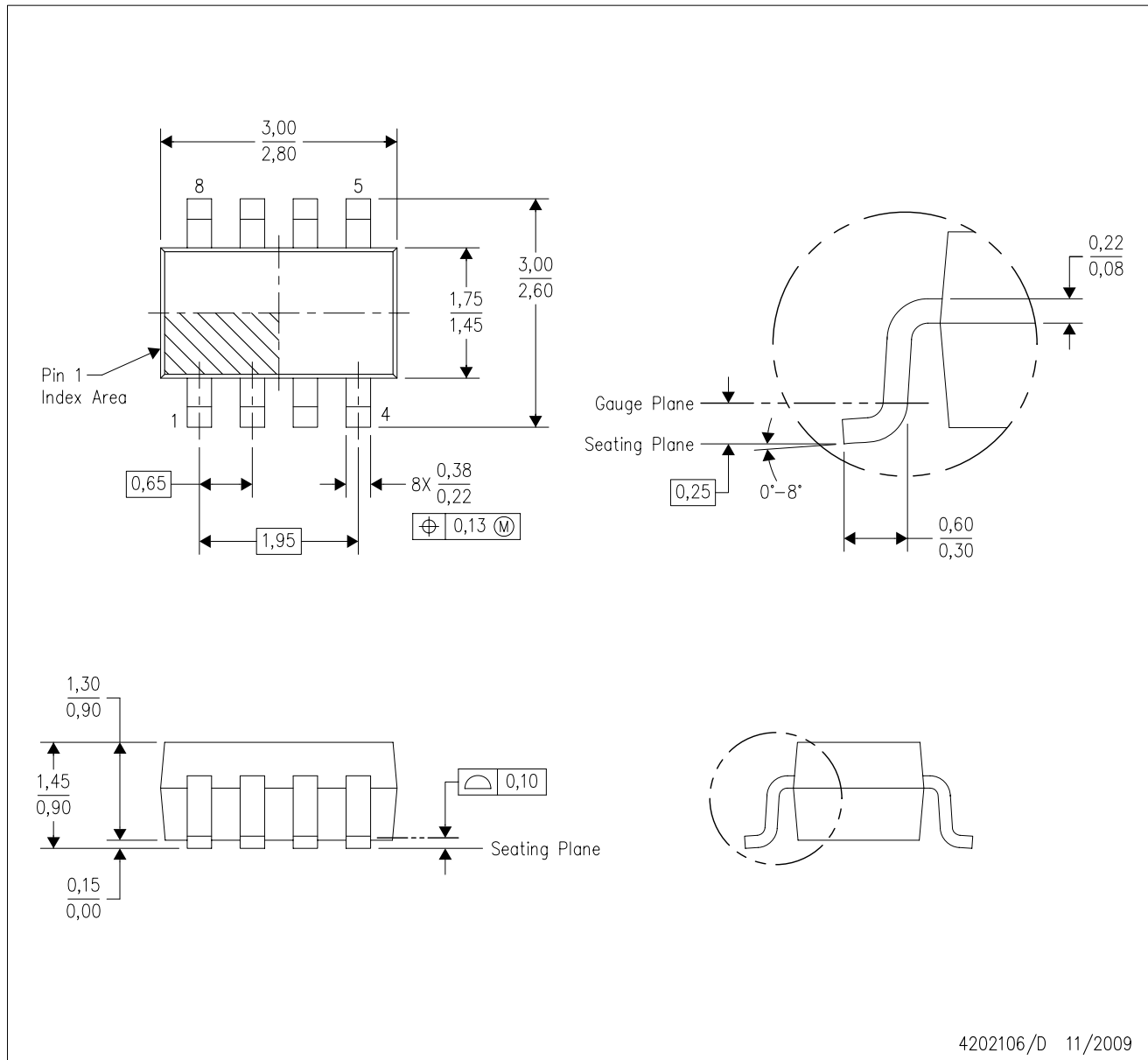

- NOTES:
- A. All linear dimensions are in millimeters.
 - B. This drawing is subject to change without notice.
 - C. Package outline exclusive of metal burr & dambar protrusion/intrusion.
 - D. Package outline inclusive of solder plating.
 - E. A visual index feature must be located within the Pin 1 index area.
 - F. Falls within JEDEC MO-178 Variation BA.
 - G. Body dimensions do not include flash or protrusion. Mold flash and protrusion shall not exceed 0.25 per side.

DCN (R-PDSO-G8)

PLASTIC SMALL-OUTLINE PACKAGE (DIE DOWN)

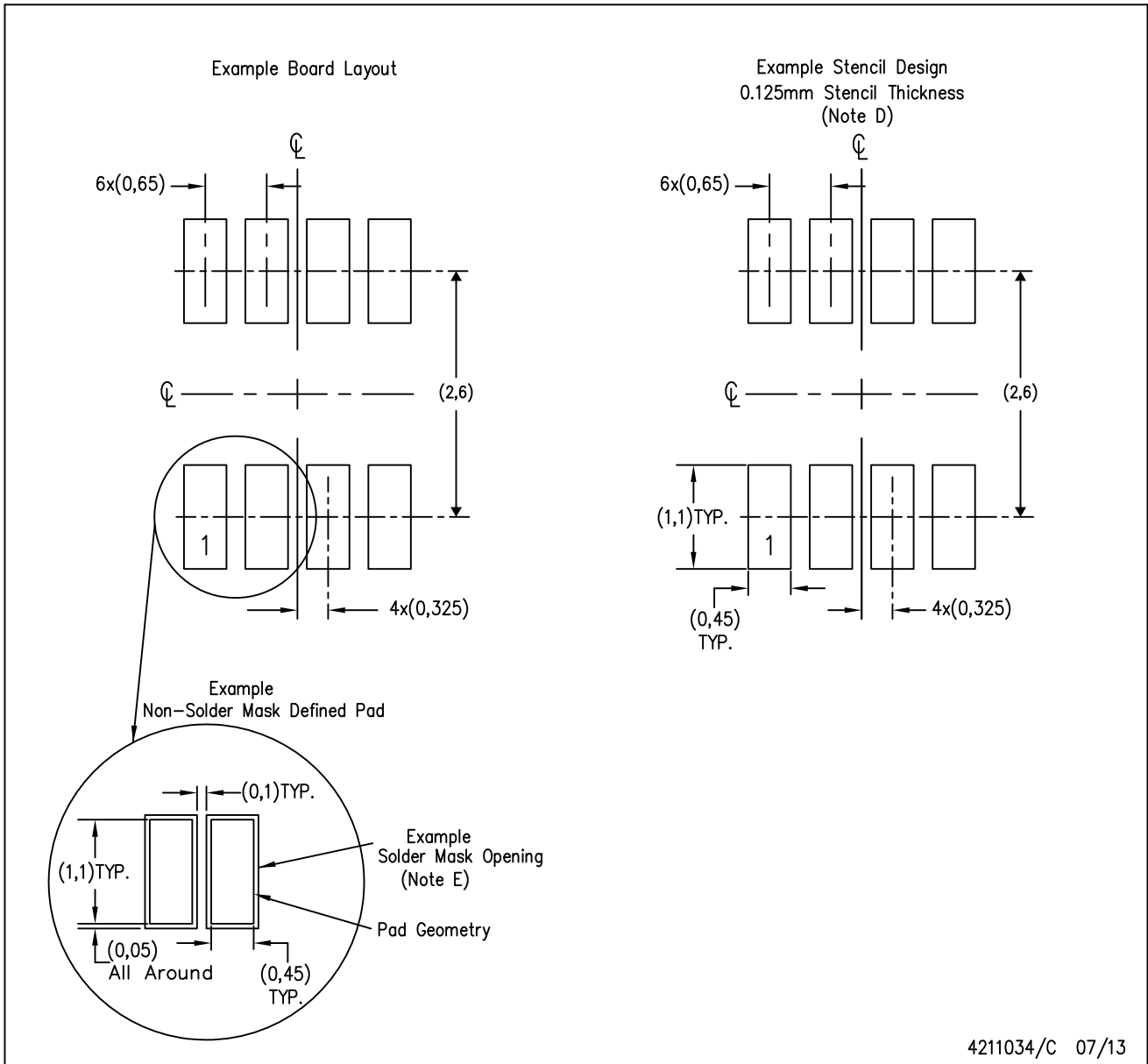

- NOTES:
- A. All linear dimensions are in millimeters.
 - B. This drawing is subject to change without notice.
 - C. Publication IPC-7351 is recommended for alternate designs.
 - D. Laser cutting apertures with trapezoidal walls and also rounding corners will offer better paste release. Customers should contact their board assembly site for stencil design recommendations. Refer to IPC-7525.
 - E. Customers should contact their board fabrication site for solder mask tolerances between and around signal pads.

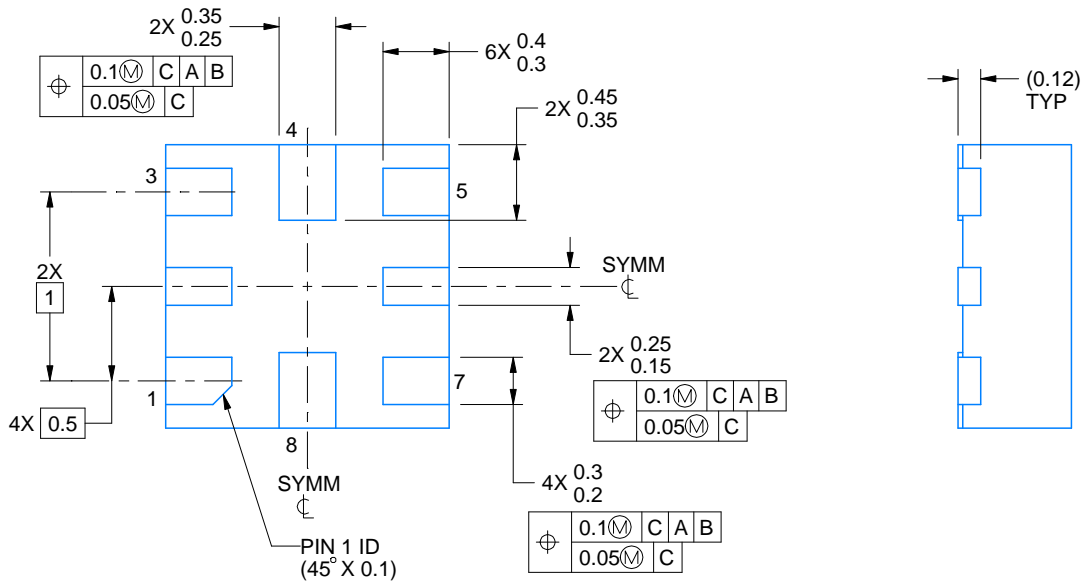
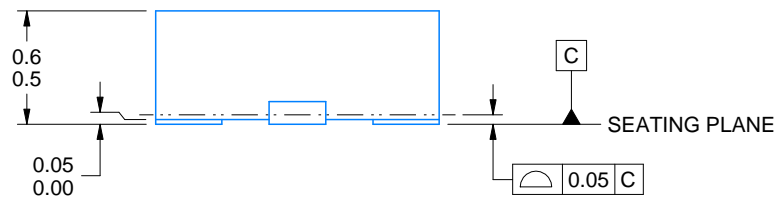
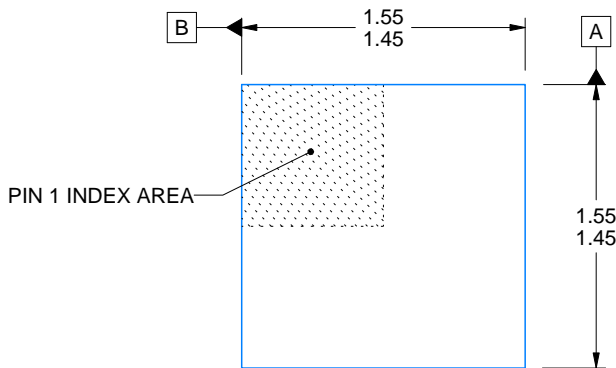
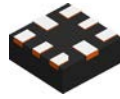

4220323/B 03/2018

NOTES:

1. All linear dimensions are in millimeters. Any dimensions in parenthesis are for reference only. Dimensioning and tolerancing per ASME Y14.5M.
2. This drawing is subject to change without notice.

EXAMPLE BOARD LAYOUT

RSE0008A

UQFN - 0.6 mm max height

PLASTIC QUAD FLATPACK - NO LEAD

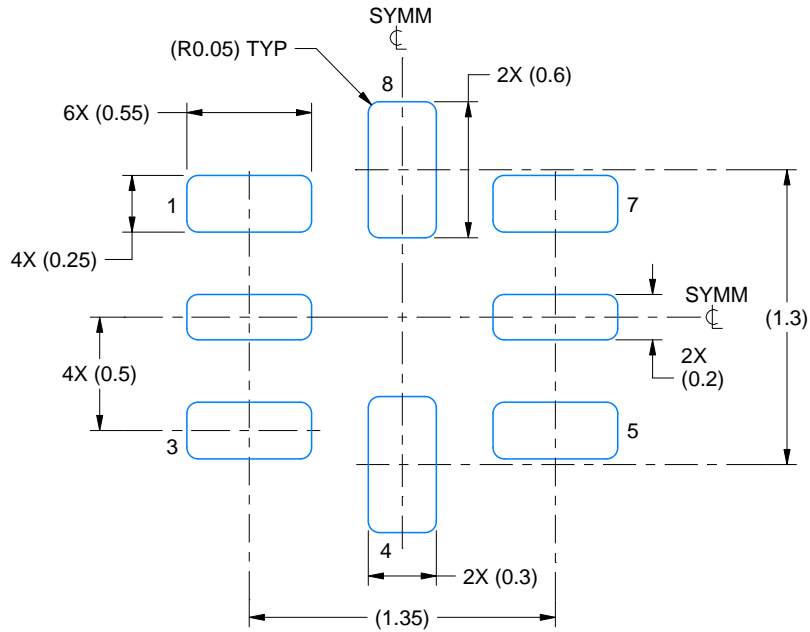

LAND PATTERN EXAMPLE
SCALE:30X

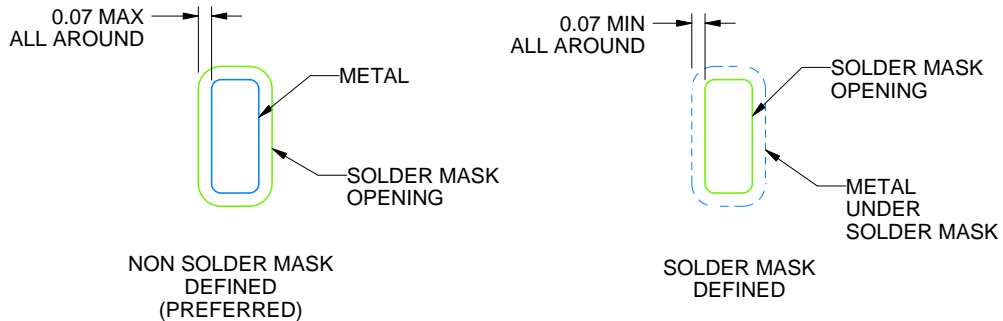

SOLDER MASK DETAILS
NOT TO SCALE

4220323/B 03/2018

NOTES: (continued)

3. For more information, see Texas Instruments literature number SLUA271 (www.ti.com/lit/slua271).

EXAMPLE STENCIL DESIGN

RSE0008A

UQFN - 0.6 mm max height

PLASTIC QUAD FLATPACK - NO LEAD

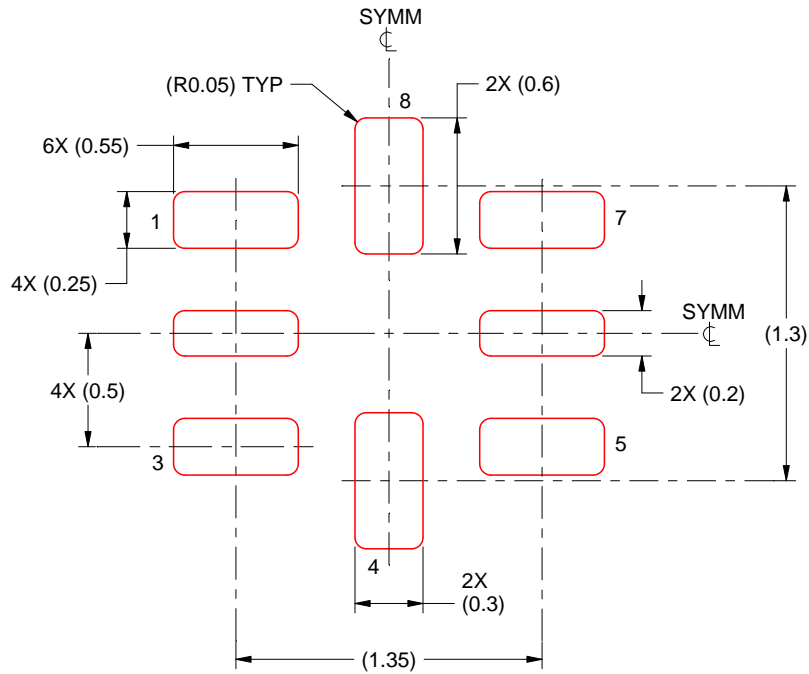

SOLDER PASTE EXAMPLE
BASED ON 0.1 mm THICKNESS
SCALE: 30X

4220323/B 03/2018

NOTES: (continued)

5. Laser cutting apertures with trapezoidal walls and rounded corners may offer better paste release. IPC-7525 may have alternate design recommendations.

IMPORTANT NOTICE

Texas Instruments Incorporated (TI) reserves the right to make corrections, enhancements, improvements and other changes to its semiconductor products and services per JESD46, latest issue, and to discontinue any product or service per JESD48, latest issue. Buyers should obtain the latest relevant information before placing orders and should verify that such information is current and complete.

TI's published terms of sale for semiconductor products (<http://www.ti.com/sc/docs/stdterms.htm>) apply to the sale of packaged integrated circuit products that TI has qualified and released to market. Additional terms may apply to the use or sale of other types of TI products and services.

Reproduction of significant portions of TI information in TI data sheets is permissible only if reproduction is without alteration and is accompanied by all associated warranties, conditions, limitations, and notices. TI is not responsible or liable for such reproduced documentation. Information of third parties may be subject to additional restrictions. Resale of TI products or services with statements different from or beyond the parameters stated by TI for that product or service voids all express and any implied warranties for the associated TI product or service and is an unfair and deceptive business practice. TI is not responsible or liable for any such statements.

Buyers and others who are developing systems that incorporate TI products (collectively, "Designers") understand and agree that Designers remain responsible for using their independent analysis, evaluation and judgment in designing their applications and that Designers have full and exclusive responsibility to assure the safety of Designers' applications and compliance of their applications (and of all TI products used in or for Designers' applications) with all applicable regulations, laws and other applicable requirements. Designer represents that, with respect to their applications, Designer has all the necessary expertise to create and implement safeguards that (1) anticipate dangerous consequences of failures, (2) monitor failures and their consequences, and (3) lessen the likelihood of failures that might cause harm and take appropriate actions. Designer agrees that prior to using or distributing any applications that include TI products, Designer will thoroughly test such applications and the functionality of such TI products as used in such applications.

TI's provision of technical, application or other design advice, quality characterization, reliability data or other services or information, including, but not limited to, reference designs and materials relating to evaluation modules, (collectively, "TI Resources") are intended to assist designers who are developing applications that incorporate TI products; by downloading, accessing or using TI Resources in any way, Designer (individually or, if Designer is acting on behalf of a company, Designer's company) agrees to use any particular TI Resource solely for this purpose and subject to the terms of this Notice.

TI's provision of TI Resources does not expand or otherwise alter TI's applicable published warranties or warranty disclaimers for TI products, and no additional obligations or liabilities arise from TI providing such TI Resources. TI reserves the right to make corrections, enhancements, improvements and other changes to its TI Resources. TI has not conducted any testing other than that specifically described in the published documentation for a particular TI Resource.

Designer is authorized to use, copy and modify any individual TI Resource only in connection with the development of applications that include the TI product(s) identified in such TI Resource. NO OTHER LICENSE, EXPRESS OR IMPLIED, BY ESTOPPEL OR OTHERWISE TO ANY OTHER TI INTELLECTUAL PROPERTY RIGHT, AND NO LICENSE TO ANY TECHNOLOGY OR INTELLECTUAL PROPERTY RIGHT OF TI OR ANY THIRD PARTY IS GRANTED HEREIN, including but not limited to any patent right, copyright, mask work right, or other intellectual property right relating to any combination, machine, or process in which TI products or services are used. Information regarding or referencing third-party products or services does not constitute a license to use such products or services, or a warranty or endorsement thereof. Use of TI Resources may require a license from a third party under the patents or other intellectual property of the third party, or a license from TI under the patents or other intellectual property of TI.

TI RESOURCES ARE PROVIDED "AS IS" AND WITH ALL FAULTS. TI DISCLAIMS ALL OTHER WARRANTIES OR REPRESENTATIONS, EXPRESS OR IMPLIED, REGARDING RESOURCES OR USE THEREOF, INCLUDING BUT NOT LIMITED TO ACCURACY OR COMPLETENESS, TITLE, ANY EPIDEMIC FAILURE WARRANTY AND ANY IMPLIED WARRANTIES OF MERCHANTABILITY, FITNESS FOR A PARTICULAR PURPOSE, AND NON-INFRINGEMENT OF ANY THIRD PARTY INTELLECTUAL PROPERTY RIGHTS. TI SHALL NOT BE LIABLE FOR AND SHALL NOT DEFEND OR INDEMNIFY DESIGNER AGAINST ANY CLAIM, INCLUDING BUT NOT LIMITED TO ANY INFRINGEMENT CLAIM THAT RELATES TO OR IS BASED ON ANY COMBINATION OF PRODUCTS EVEN IF DESCRIBED IN TI RESOURCES OR OTHERWISE. IN NO EVENT SHALL TI BE LIABLE FOR ANY ACTUAL, DIRECT, SPECIAL, COLLATERAL, INDIRECT, PUNITIVE, INCIDENTAL, CONSEQUENTIAL OR EXEMPLARY DAMAGES IN CONNECTION WITH OR ARISING OUT OF TI RESOURCES OR USE THEREOF, AND REGARDLESS OF WHETHER TI HAS BEEN ADVISED OF THE POSSIBILITY OF SUCH DAMAGES.

Unless TI has explicitly designated an individual product as meeting the requirements of a particular industry standard (e.g., ISO/TS 16949 and ISO 26262), TI is not responsible for any failure to meet such industry standard requirements.

Where TI specifically promotes products as facilitating functional safety or as compliant with industry functional safety standards, such products are intended to help enable customers to design and create their own applications that meet applicable functional safety standards and requirements. Using products in an application does not by itself establish any safety features in the application. Designers must ensure compliance with safety-related requirements and standards applicable to their applications. Designer may not use any TI products in life-critical medical equipment unless authorized officers of the parties have executed a special contract specifically governing such use. Life-critical medical equipment is medical equipment where failure of such equipment would cause serious bodily injury or death (e.g., life support, pacemakers, defibrillators, heart pumps, neurostimulators, and implantables). Such equipment includes, without limitation, all medical devices identified by the U.S. Food and Drug Administration as Class III devices and equivalent classifications outside the U.S.

TI may expressly designate certain products as completing a particular qualification (e.g., Q100, Military Grade, or Enhanced Product). Designers agree that it has the necessary expertise to select the product with the appropriate qualification designation for their applications and that proper product selection is at Designers' own risk. Designers are solely responsible for compliance with all legal and regulatory requirements in connection with such selection.

Designer will fully indemnify TI and its representatives against any damages, costs, losses, and/or liabilities arising out of Designer's non-compliance with the terms and provisions of this Notice.