

REF. -50 OPT. SCREW
(WHERE APPLICABLE)

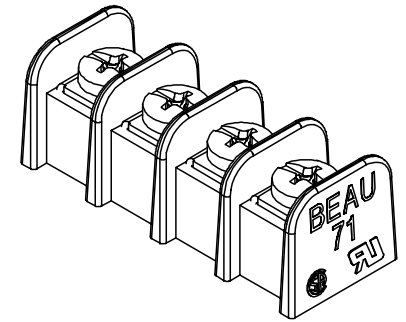

4 CIRCUIT SHOWN

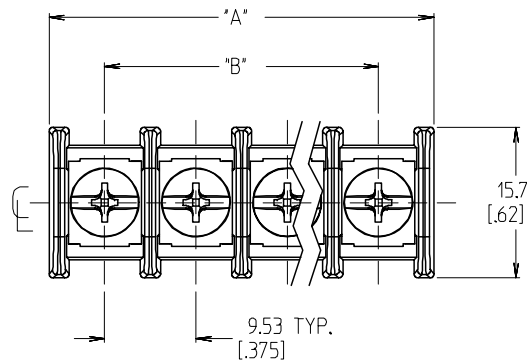
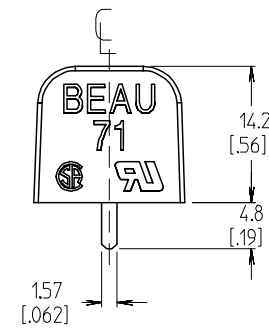
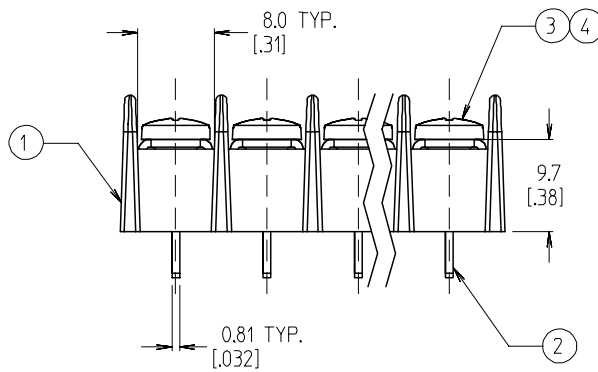

NOTES:

- 1. MATERIAL: SEE TABLE
- 2. FINISH: SEE TABLE
- 3. INCH DMS ARE SHOWN IN BRACKETS [XXX].
- 4. "XX" REFERS TO THE NUMBER OF CIRCUITS.
- 5. ALL COMPONENTS ARE ROHS COMPLIANT.

ITEM	QTY.	DESCRIPTION	MATERIAL	FINISH	INITIAL RELEASE	QUALITY SYMBOLS	GENERAL TOLERANCES (UNLESS SPECIFIED)		DIMENSION STYLE	SCALE	DESIGN UNITS	THIRD ANGLE PROJECTION		
							mm	INCH	MM/IN	2:1	INCH	☉		
5	XX	SCREW&WASHER, #6-32X.250, PAN, PH/SL (-50 OPT)	STEEL	ZN, CLEAR CHROMATE	EC NO: ETC2006-0520 DRW:CYORK 2006/07/12 CHK:RDEROSS 2006/07/13 APPR:RDEROSS 2006/07/13	▽=0 ▽=0	4 PLACES	± ---	± ---	DRAWN BY	DATE	TITLE 9.53MM [.375] SR BTS ASSY, PC TERM. WITHOUT MTG. ENDS, LOW PROF. MOLEX INCORPORATED		
4	XX	SCREW, #6-32X.250, BHD, PH/SL (-49 OPT)	BRASS	NICKEL PLATE			3 PLACES	± ---	± .005	C. YORK	2006/06/30		MATERIAL NO. SEE SHEET 2 DOCUMENT NO. SD-38710-005	
3	XX	SCREW, #6-32X.250, BHD, PH/SL (STD)	STEEL	ZN, CLEAR CHROMATE			2 PLACES	± 0.13	± .01	R. DEROSS	2006/06/30			SHEET NO. 1 OF 2
2	XX	TERMINAL, PC, #6-32	BRASS	TIN PLATE			1 PLACE	± 0.25	± ---	R. DEROSS	2006/06/30			
1	1	INSULATOR, SR, NO MTG.	30% G.F. PBT	BLACK			ANGULAR ± 2 °		APPROVED BY		DATE			
					DRAFT WHERE APPLICABLE MUST REMAIN WITHIN DIMENSIONS		MATERIAL NO. SEE SHEET 2		DOCUMENT NO. SD-38710-005					

NO. OF CIRCUITS	DIM. "A"		DIM. "B"		ASSEMBLY MATERIAL NO. (STANDARD)	ASSEMBLY MATERIAL NO. (-49 OPT)	ASSEMBLY MATERIAL NO. (-50 OPT)
	mm	in	mm	in			
02	21.1	0.83	9.53	0.375	387106302	387106902	387107502
03	30.7	1.21	19.05	0.750	387106303	387106903	387107503
04	40.2	1.58	28.58	1.125	387106304	387106904	387107504
05	49.7	1.96	38.10	1.500	387106305	387106905	387107505
06	59.2	2.33	47.63	1.875	387106306	387106906	387107506
07	68.8	2.71	57.15	2.250	387106307	387106907	387107507
08	78.3	3.08	66.68	2.625	387106308	387106908	387107508
09	87.8	3.46	76.20	3.000	387106309	387106909	387107509
10	97.3	3.83	85.73	3.375	387106310	387106910	387107510
11	106.9	4.21	95.25	3.750	387106311	387106911	387107511
12	116.4	4.58	104.78	4.125	387106312	387106912	387107512
13	125.9	4.96	114.30	4.500	387106313	387106913	387107513
14	135.4	5.33	123.83	4.875	387106314	387106914	387107514
15	145.0	5.71	133.35	5.250	387106315	387106915	387107515
16	154.5	6.08	142.88	5.625	387106316	387106916	387107516
17	164.0	6.46	152.40	6.000	387106317	387106917	387107517
18	173.5	6.83	161.93	6.375	387106318	387106918	387107518
19	183.1	7.21	171.45	6.750	387106319	387106919	387107519
20	192.6	7.58	180.98	7.125	387106320	387106920	387107520
21	202.1	7.96	190.50	7.500	387106321	387106921	387107521
22	211.6	8.33	200.03	7.875	387106322	387106922	387107522
23	221.2	8.71	209.55	8.250	387106323	387106923	387107523
24	230.7	9.08	219.08	8.625	387106324	387106924	387107524
25	240.2	9.46	228.60	9.000	387106325	387106925	387107525
26	249.7	9.83	238.13	9.375	387106326	387106926	387107526

SEE SHEET 1	EC NO: ETC2006-0520 DRWN: CYORK 2006/07/12 CHKD: RDEROSS 2006/07/13 APPR: RDEROSS 2006/07/13	DESCRIPTION	QUALITY SYMBOLS	GENERAL TOLERANCES (UNLESS SPECIFIED)	DIMENSION STYLE	SCALE	DESIGN UNITS	THIRD ANGLE PROJECTION										
			$\nabla = 0$ $\nabla = 0$	<table border="1"> <tr><th>mm</th><th>INCH</th></tr> <tr><td>4 PLACES ± ---</td><td>± ---</td></tr> <tr><td>3 PLACES ± ---</td><td>± .005</td></tr> <tr><td>2 PLACES ± 0.13</td><td>± .01</td></tr> <tr><td>1 PLACE ± 0.25</td><td>± ---</td></tr> </table>	mm	INCH	4 PLACES ± ---	± ---	3 PLACES ± ---	± .005	2 PLACES ± 0.13	± .01	1 PLACE ± 0.25	± ---	MM/IN	2:1	INCH	
			mm	INCH														
			4 PLACES ± ---	± ---														
3 PLACES ± ---	± .005																	
2 PLACES ± 0.13	± .01																	
1 PLACE ± 0.25	± ---																	
REV	<table border="1"> <tr><th>DRAWN BY</th><th>DATE</th></tr> <tr><td>C. YORK</td><td>2006/06/30</td></tr> <tr><th>CHECKED BY</th><th>DATE</th></tr> <tr><td>R. DEROSS</td><td>2006/06/30</td></tr> <tr><th>APPROVED BY</th><th>DATE</th></tr> <tr><td>R. DEROSS</td><td>2006/06/30</td></tr> </table>	DRAWN BY	DATE	C. YORK	2006/06/30	CHECKED BY	DATE	R. DEROSS	2006/06/30	APPROVED BY	DATE	R. DEROSS	2006/06/30	TITLE	9.53MM [.375] SR BTS ASSY, PC TERM. WITHOUT MTG. ENDS, LOW PROF.			
DRAWN BY	DATE																	
C. YORK	2006/06/30																	
CHECKED BY	DATE																	
R. DEROSS	2006/06/30																	
APPROVED BY	DATE																	
R. DEROSS	2006/06/30																	
A	<table border="1"> <tr><th>MATERIAL NO.</th><th>DOCUMENT NO.</th><th>SHEET NO.</th></tr> <tr><td>SEE CHART</td><td>SD-38710-005</td><td>2 OF 2</td></tr> </table>	MATERIAL NO.	DOCUMENT NO.	SHEET NO.	SEE CHART	SD-38710-005	2 OF 2	MOLEX INCORPORATED										
MATERIAL NO.	DOCUMENT NO.	SHEET NO.																
SEE CHART	SD-38710-005	2 OF 2																

Mouser Electronics

Authorized Distributor

Click to View Pricing, Inventory, Delivery & Lifecycle Information:

[Molex:](#)

[38710-7509](#)