

THIS DRAWING IS UNPUBLISHED. RELEASED FOR PUBLICATION
 © COPYRIGHT - By - ALL RIGHTS RESERVED.

REVISIONS				
P	LTR	DESCRIPTION	DATE	APVD
Z5		REMOVED 62431-7	09MAY2019	SV PKS

- 1 CONTINUOUS STRIP ON REELS WITH TERMINALS LOCATED ON 5.59±0.08 [.220±.003] CENTERS.
- 2 SLOT ACCEPTS 0.18-0.23mm [#33-#31] AWG COPPER MAGNET WIRE. 2 WIRES OF THE SAME SIZE PER SLOT.
- 3 POKE-IN ACCEPTS A 0.50-0.90mm² [#20-#18] AWG SOLID OR FUSED STRANDED LEAD WIRE.
- 4 SPECIAL REEL QUANTITY - SPAIN PRODUCTION ONLY.

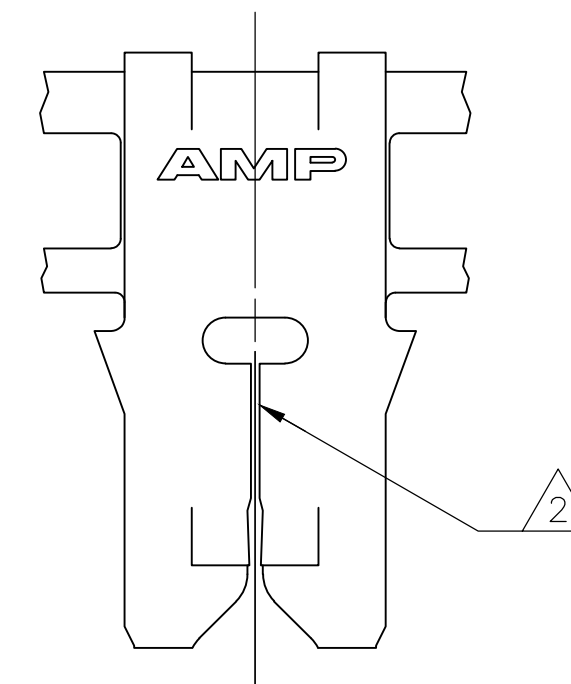
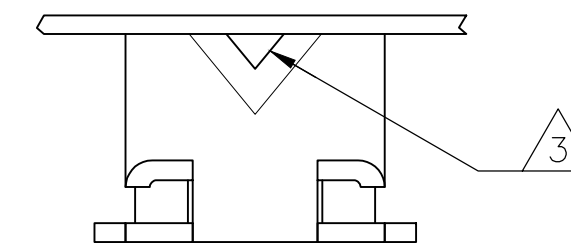
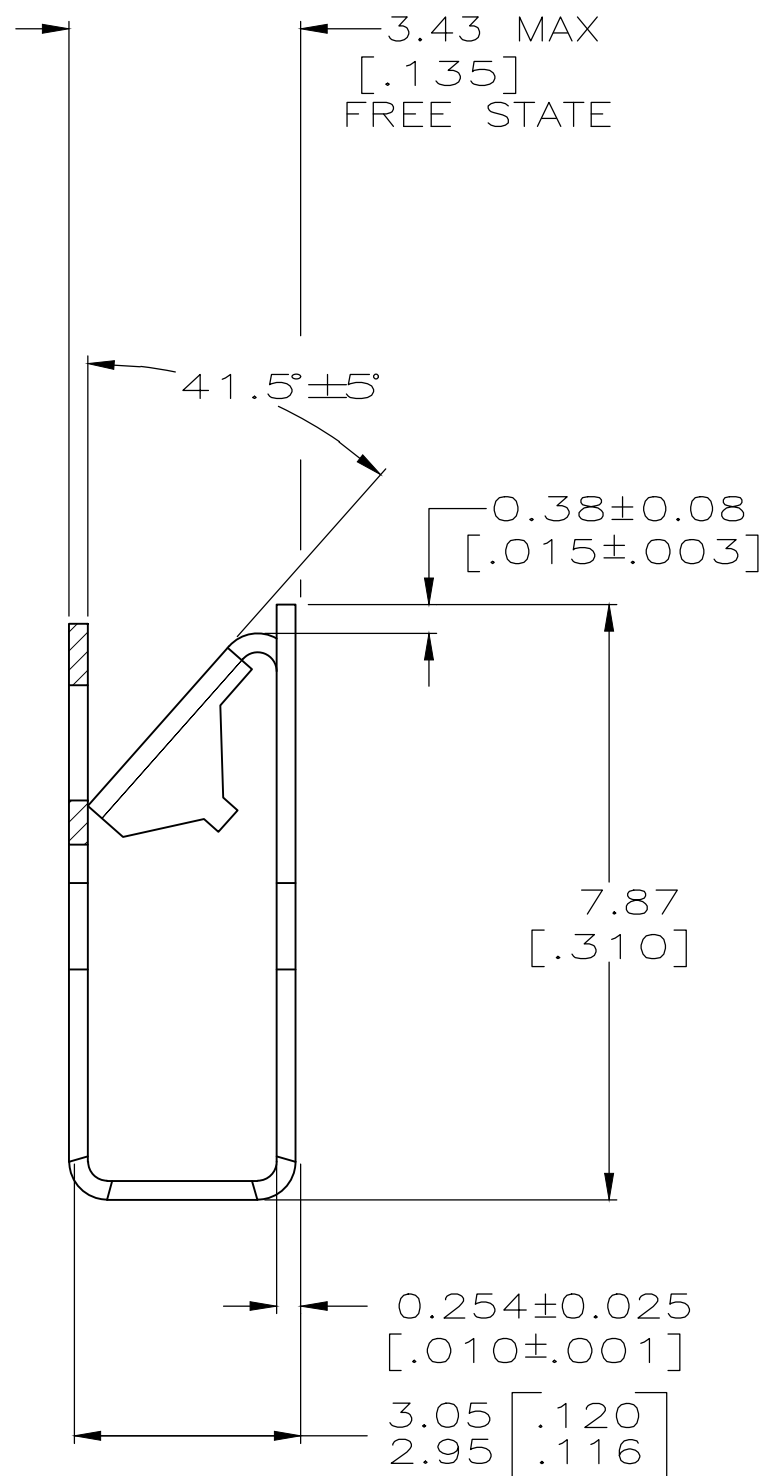
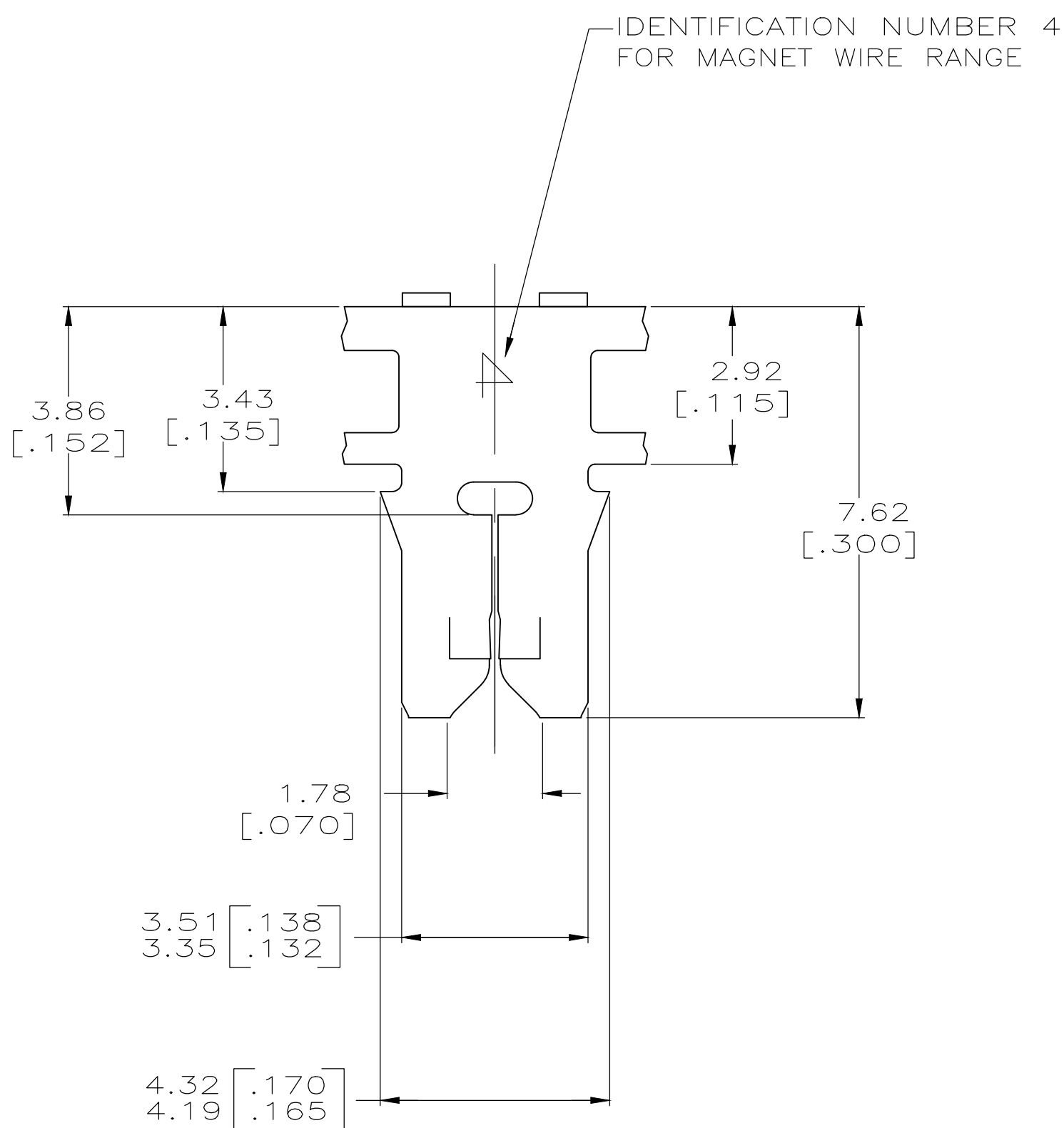

PAPER SPLICE	WITH PAPER	TIN PLATE	BRASS	62431-6
WELD SPLICE	WITH PAPER	TIN PLATE	BRASS	4 62431-5
		-	-	-
WELD SPLICE	PLASTIC REEL W/ PAPER	UNPLATED	BRASS	62431-2
WELD SPLICE	WITH PAPER	TIN PLATE	BRASS	62431-1
SPLICE	REELING	FINISH	MATERIAL	PART NO

THIS DRAWING IS A CONTROLLED DOCUMENT.

DIMENSIONS: INCHES	TOLERANCES UNLESS OTHERWISE SPECIFIED:	DWN 23/JUN/94 R.R. BUCHEISTER JR.	
		CHK 24/JUN/94 MICHAEL S. FEHER	
		APVD 27/JUN/94 NELSON E. NEFF	NAME
		PRODUCT SPEC 108-2012	TERMINAL, POKE-IN, 300 SERIES MAG-MATE™
		APPLICATION SPEC 114-2046	SIZE CAGE CODE DRAWING NO RESTRICTED TO
MATERIAL SEE TABLE	FINISH SEE TABLE	WEIGHT 0	A2 00779 C-62431
		CUSTOMER DRAWING	SCALE 10:1 SHEET 1 OF 1 REV Z5