

Recommended PCB Layout
General Tolerance ± 0.05

as viewed from component side

Solder Area
 Keep Out Area
 Component Outline

- Section A-A**
- C1 → VCC
 - C2 → RST
 - C3 → CLK
 - C5 → GND
 - C6 → Vpp
 - C7 → IO

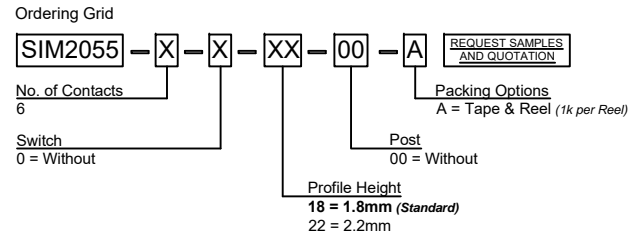
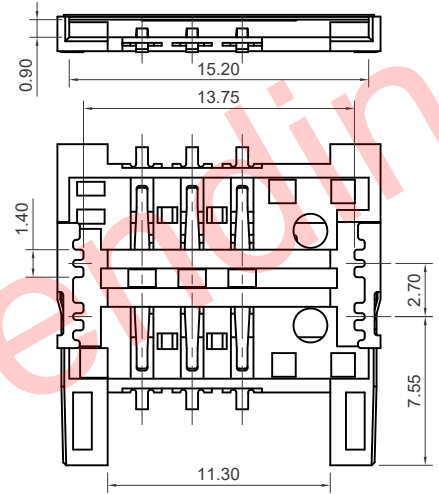

Specifications 规格:

Material 物料规格:
 Plastic Housing 塑胶外壳: LCP(MG350) UL94V-0, Black LCP 高温塑胶, 黑色
 Contact Terminal 接触端子: Phosphor Bronze (T=0.15 \pm 0.01mm) 磷青铜
 Metallic Shell 金属外壳: Stainless Steel(SUS304R-H,T=0.15mm) 不锈钢

Plating 电镀规格:
 Contact Terminal plating 端子电镀:
 Under-plating 底层电镀: 50 μ " min. Nickel over all 全部镀镍最少50 μ "
 Contact Area 接触区: 15 μ " Gold 镀金15 μ "
 Soldering Area 焊接区: Gold Flash 镀闪金
 Metallic Shell plating 金属外壳电镀:
 Under-plating 底层电镀: Nickel all over 全部镀镍
 Soldering Area 焊接区: Gold Flash 镀闪金

Electrical 电气规格:
 Voltage rating 电压额定值: 250 V (R.M.S.) max.
 Current rating 电流额定值: 1 A max.
 Operating Temperature 工作温度: -55°C to +105°C
 Contact Resistance 接触电阻值: 50 m Ω max.
 Insulating Resistance 绝缘电阻值: 100 M Ω min. (Apply 施加250 V DC)
 Dielectric Withstand Voltage 介电耐压: Current Leakage 漏电流 0.5 mA (Apply 500 V AC for 1 minute 施加500 V AC共1分钟)

Mechanical 机械性规格:
 Durability 耐久性: 5,000 cycles 5,000 次插拔
 Contact Normal Force 端子正向力: 50gf/Pin
 Contact Retention Force 端子保持力: 50gf/Pin

Part Number		Product Description	
SIM2055		SIM Card Connector, Receiver Type	
Drawing Date		6 Pin, SMT, 1.8mm or 2.2mm Profile	
23rd August 2007			
By	AJO	Tolerances (Except as Noted)	
Detail	SIM2055	Length	Angle
Revision	I	X. \pm 0.50	X. $^{\circ}$ \pm 2 $^{\circ}$
Date	14/07/14	X.X \pm 0.30	X.X $^{\circ}$ \pm 1 $^{\circ}$
		X.XX \pm 0.20	
		Units:	Metric (mm)
		3rd Angle Projection	
		ROHS COMPLIANT 2011/08/EU Deca-BDE	
		This drawing is confidential and copyright of Global Connector Technology, Ltd (GCT). This drawing must not be copied or disclosed without written consent. E & OE	

GCT
www.gct.co

Not to Scale Drawn By PKN Sheet No. 1/2

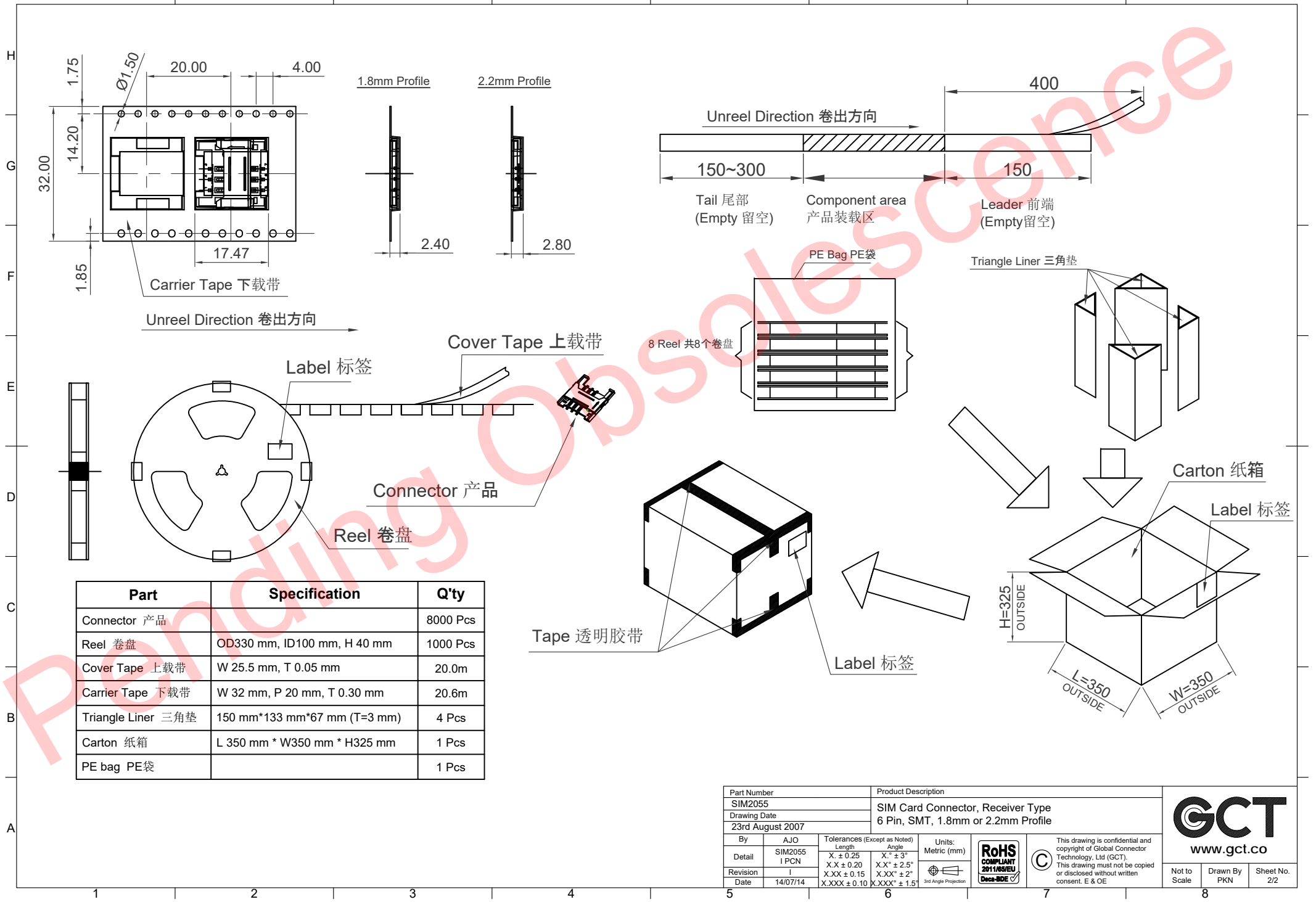

Part	Specification	Q'ty
Connector 产品		8000 Pcs
Reel 卷盘	OD330 mm, ID100 mm, H 40 mm	1000 Pcs
Cover Tape 上载带	W 25.5 mm, T 0.05 mm	20.0m
Carrier Tape 下载带	W 32 mm, P 20 mm, T 0.30 mm	20.6m
Triangle Liner 三角垫	150 mm*133 mm*67 mm (T=3 mm)	4 Pcs
Carton 纸箱	L 350 mm * W350 mm * H325 mm	1 Pcs
PE bag PE袋		1 Pcs

Part Number		Product Description	
SIM2055		SIM Card Connector, Receiver Type	
Drawing Date		6 Pin, SMT, 1.8mm or 2.2mm Profile	
23rd August 2007			
By	AJO	Tolerances (Except as Noted)	
Detail	SIM2055	Length	Angle
Revision	I	X. ± 0.25	X.° ± 3°
Date	14/07/14	X.X ± 0.20	X.X° ± 2.5°
		X.XX ± 0.15	X.XX° ± 2°
		X.XXX ± 0.10	X.XXX° ± 1.5°
		Units:	Metric (mm)

GCT
www.gct.co

This drawing is confidential and copyright of Global Connector Technology, Ltd (GCT). This drawing must not be copied or disclosed without written consent. E & OE

Not to Scale Drawn By PKN Sheet No. 2/2