

Filters for Power Lines (Low leakage current)

16 to 100 A,
100 dB from 14 kHz

Series/Type: B84263

Date: January 2004

© EPCOS AG 2015. Reproduction, publication and dissemination of this publication, enclosures hereto and the information contained therein without EPCOS' prior express consent is prohibited.

EPCOS AG is a TDK Group Company.

2- and 4-line-filters

16 to 100 A

Multi-stage

Stopband attenuation 14 kHz to 40 GHz



Features

- Low volume and low voltage drop
- Practically no leakage current flow on the grounding conductor in normal operation because of the capacitor configuration (capacitive circuit to ground only through neutral)
- Insertion loss to CISPR 17

Design

The electrical components are incorporated in an RF-tight case of high-grade steel. The cables enter through glands. The RF-tight termination of the openings is produced by specially shaped lids.

The conductors and equipment grounding conductor are connected by threaded bolts. The surface around the fixing holes is left as bare metal (unpainted) to ensure good RF contact with metal surfaces (chassis, ground).

Protective measures (grounding)

The high capacitances between the lines and ground require special protective measures. If there are no product-specific requirements, protection with a secondary ground wire (cross section min. 10 mm²) in accordance with EN 50178 is necessary. For this purpose the filter case have connecting bolts at each end.

Resistors are incorporated in the filter to discharge capacitors after turn-off.

Scope of supply

Filters are supplied complete with all parts required for RF-tight installation (fixing screws, flanges, RF gaskets, cable glands) and installation instructions.

Installation

No welding is needed on the shielding wall, so any subsequent installation is quite simple. And the uniform template of the attachment points allows straightforward replacement of 2-line filters by 4-line filters for example.

Accessories and special versions

RF-tight flexible connector fittings are available for installation spaced away from the shielding wall. Filters with an EMP protection add-on for surge currents up to 100 kA per line are available on request. To match requirements, filters can be supplied with different kinds of EMC or shielding cable glands.

Tests

All filters are 100% tested and the results are archived under a filter's serial number. If required, a test report can be generated for the serial number.

Circuit diagrams

2-line filters

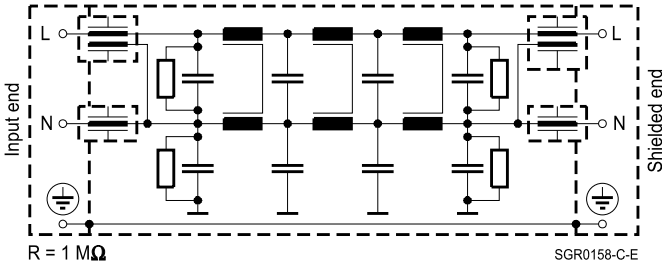

4-line filters

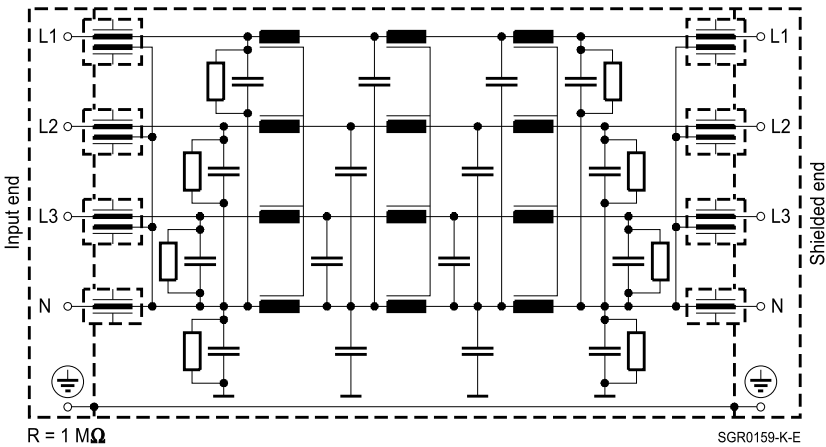

Insertion loss α_e (typical values at $Z = 50 \Omega$)

Measurement circuit

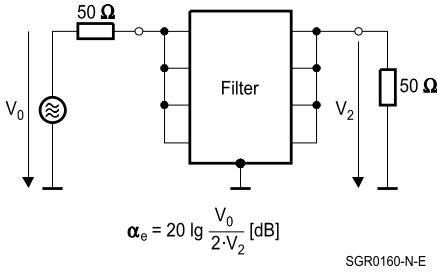
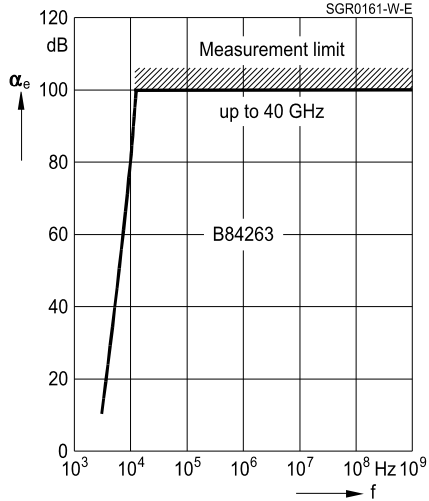
 Asymmetrical measurement circuit
to MIL-STD-220A

General technical data

Rated voltage 2-line filters	V_R	250	V	Line/line Line/case
Rated voltage 4-line filters	V_R	440 250	V V	Line/line Line/case
Rated frequency	f_R	50/60	Hz	
Rated current	I_R	See characteristics		Referred to +40 °C ambient temperature
Maximum admissible overcurrent	I_{over}	75 · I_R for 50 ms 10 · I_R for 1 s 2 · I_R for 1 min 1.4 · I_R for 15 min		
Test voltage	V_{test}	1200 VDC, 2 s 1200 VDC, 2 s		Line/line Line/case
Voltage drop/phase	ΔV	<1	%	Of V_R at 50 Hz and I_R
Maximum DC resistance	R_{max}	See characteristics		Per line

General technical data (continued)

Power dissipation	P_D	See characteristics	At rated current I_R
Capacitive leakage current	I_{leak}	See characteristics	Difference potential N to PE at 50 Hz
Max. permissible harmonic distortion (THD)		8 %	To EN 50160
Permissible ambient temperature	T_A	-25/+40 °C	
Climatic category (EN 60068-1)		25/085/56	-25 °C/+85 °C/56 days damp heat test
Mechanical version		C	Cable glands at both ends or flexible connector fitting
		D	Direct connection to shielding wall

Characteristics and ordering codes

I_R	Mechanical version	R_{max}	P_D	I_{leak}	Dimensional drawing	Page	Approx. weight kg	Ordering code
A		mΩ	W	mA/V				
2-line filters								
16	C	< 40	< 18	< 2	1	6	8	B84263C0022B013
16	D	< 40	< 18	< 2	2	7	8	B84263D0022B013
40	C	< 20	< 60	< 2.5	3	8	18	B84263C0023B013
40	D	< 20	< 60	< 2.5	4	9	18	B84263D0023B013
4-line filters								
16	C	< 80	< 60	< 2	5	10	25	B84263C1160E003
16	D	< 80	< 60	< 2	6	11	25	B84263D1160E003
40	C	< 30	< 140	< 2.5	7	12	27	B84263C1400E003
40	D	< 30	< 140	< 2.5	8	13	27	B84263D1400E003
100	C	< 6	< 70	< 2.5	9	14	50	B84263C1101E003
100	D	< 6	< 180	< 2.5	10	15	50	B84263D1101E003

Dimensional drawings
Dimensional drawing 1 (cable glands at both ends)
2 x 16 A

B84263C0022B013

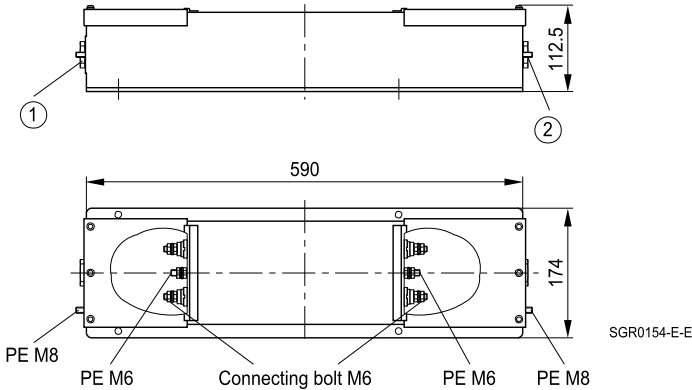

- ① Input end: Cable gland PG 21 (mounted)
- ② Shielded end: Cable gland PG 29/21
(cable gland PG 29, PG 21 and reducer ring in accessory bag)

Paint color: RAL 7035 (light gray, semigloss)

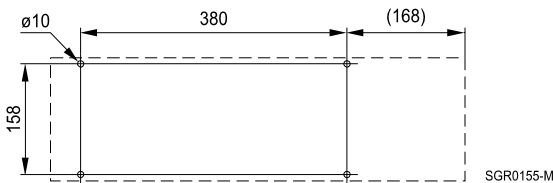
Fixing dimensions

The cable glands (with cutout sealing ring) are suitable for the following overall cable diameter:

PG 29	17 to 19 mm	20 to 22 mm	23 to 25 mm	26 to 28 mm
PG 21	9 to 11 mm	12 to 14 mm	15 to 17 mm	18 to 20 mm

RF-tight connection to shielding wall with connector fitting, see page 16.

Dimensional drawing 2 (direct connection to shielding wall)

2 x 16 A

B84263D0022B013

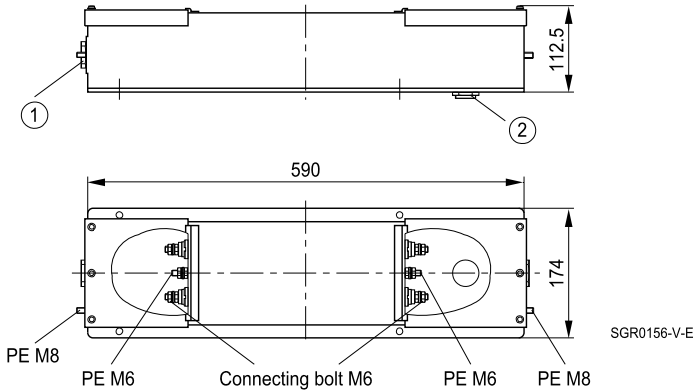

- ① Input end: Cable gland PG 21 (mounted)
- ② Shielded end: Cable gland PG 29/21
(cable gland PG 29, PG 21 and reducer ring in accessory bag)

Paint color: RAL 7035 (light gray, semigloss)

Fixing dimensions

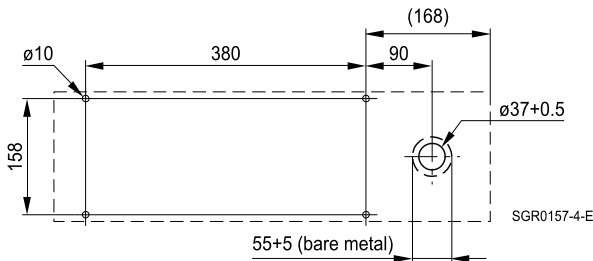

The cable glands (with cutout sealing ring) are suitable for the following overall cable diameter:

PG 29	17 to 19 mm	20 to 22 mm	23 to 25 mm	26 to 28 mm
PG 21	9 to 11 mm	12 to 14 mm	15 to 17 mm	18 to 20 mm

RF-tight connection to shielding wall, see page 16.

Dimensional drawing 3 (cable glands at both ends)
2 x 40 A

B84263C0023B013

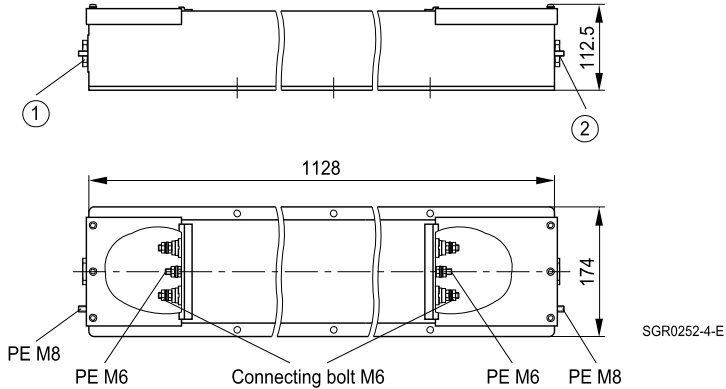

- ① Input end: Cable gland PG 21 (mounted)
- ② Shielded end: Cable gland PG 29/21
(cable gland PG 29, PG 21 and reducer ring in accessory bag)

Paint color: RAL 7035 (light gray, semigloss)

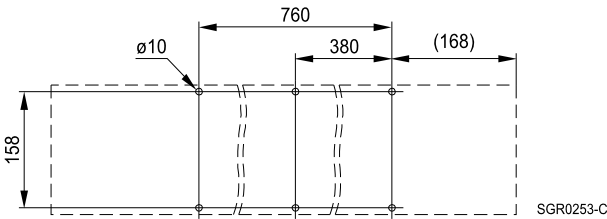
Fixing dimensions

The cable glands (with cutout sealing ring) are suitable for the following overall cable diameter:

PG 29	17 to 19 mm	20 to 22 mm	23 to 25 mm	26 to 28 mm
PG 21	9 to 11 mm	12 to 14 mm	15 to 17 mm	18 to 20 mm

RF-tight connection to shielding wall with connector fitting, see page 16.

Dimensional drawing 4 (direct connection to shielding wall)
2 x 40 A

B84263D0023B013

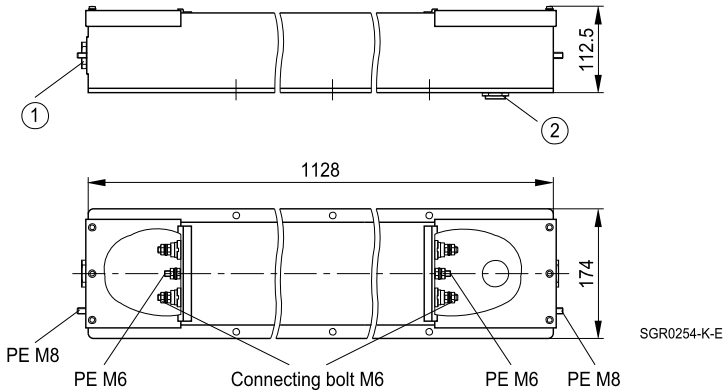

- ① Input end: Cable gland PG 21 (mounted)
- ② Shielded end: Cable gland PG 29/21
(cable gland PG 29, PG 21 and reducer ring in accessory bag)

Paint color: RAL 7035 (light gray, semigloss)

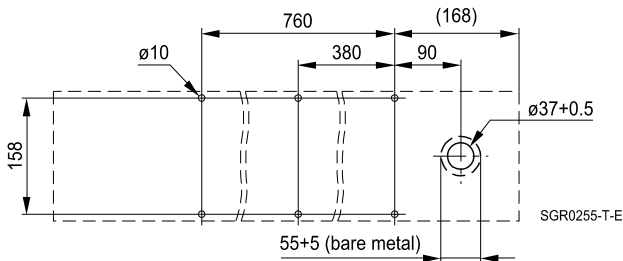
Fixing dimensions

The cable glands (with cutout sealing ring) are suitable for the following overall cable diameter:

PG 29	17 to 19 mm	20 to 22 mm	23 to 25 mm	26 to 28 mm
PG 21	9 to 11 mm	12 to 14 mm	15 to 17 mm	18 to 20 mm

RF-tight connection to shielding wall, see page 16.

Dimensional drawing 5 (cable glands at both ends)
4 x 16 A

B84263C1160E003

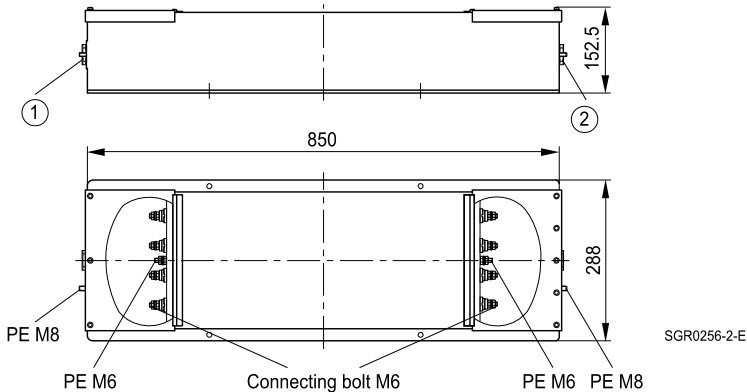

- ① Input end: Cable gland PG 29/21
(PG 29 mounted, PG 21 and reducer ring in accessory bag)
- ② Shielded end: Cable gland PG 29/21
(cable gland PG 29, PG 21 and reducer ring in accessory bag)

Paint color: RAL 7035 (light gray, semigloss)

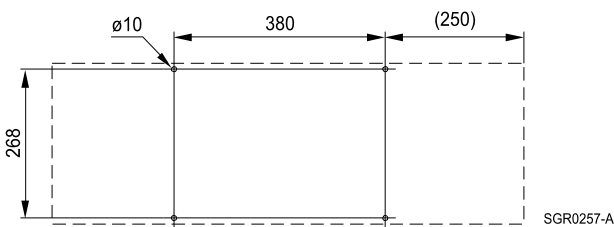
Fixing dimensions

The cable glands (with cutout sealing ring) are suitable for the following overall cable diameter:

PG 29	17 to 19 mm	20 to 22 mm	23 to 25 mm	26 to 28 mm
PG 21	9 to 11 mm	12 to 14 mm	15 to 17 mm	18 to 20 mm

RF-tight connection to shielding wall with connector fitting, see page 16.

Dimensional drawing 6 (direct connection to shielding wall)
4 x 16 A

B84263D1160E003

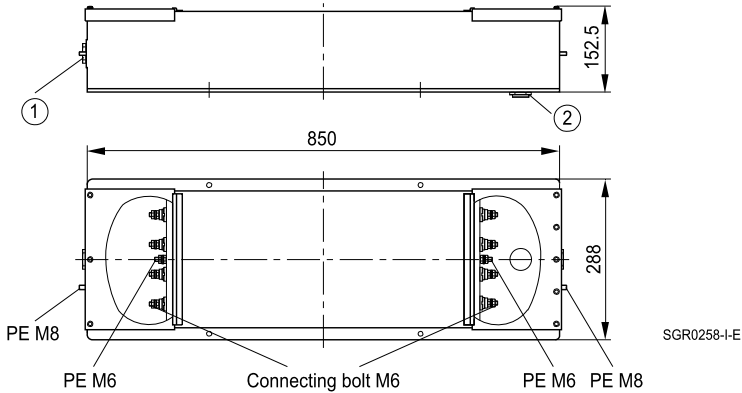

- ① Input end: Cable gland PG 29/21
(PG 29 mounted, PG 21 and reducer ring in accessory bag)
- ② Shielded end: Cable gland PG 29/21
(cable gland PG 29, PG 21 and reducer ring in accessory bag)

Paint color: RAL 7035 (light gray, semigloss)

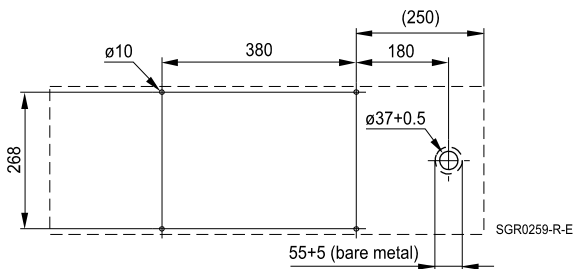
Fixing dimensions

The cable glands (with cutout sealing ring) are suitable for the following overall cable diameter:

PG 29	17 to 19 mm	20 to 22 mm	23 to 25 mm	26 to 28 mm
PG 21	9 to 11 mm	12 to 14 mm	15 to 17 mm	18 to 20 mm

RF-tight connection to shielding wall, see page 16.

Dimensional drawing 7 (cable glands at both ends)
4 x 40 A

B84263C1400E003

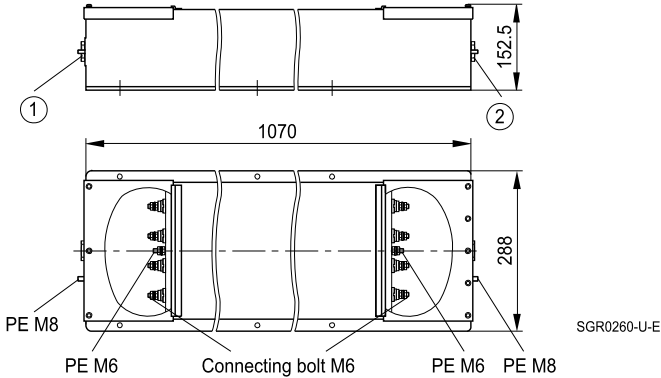

- ① Input end: Cable gland PG 29/21
(PG 29 mounted, PG 21 and reducer ring in accessory bag)
- ② Shielded end: Cable gland PG 29/21
(cable gland PG 29, PG 21 and reducer ring in accessory bag)

Paint color: RAL 7035 (light gray, semigloss)

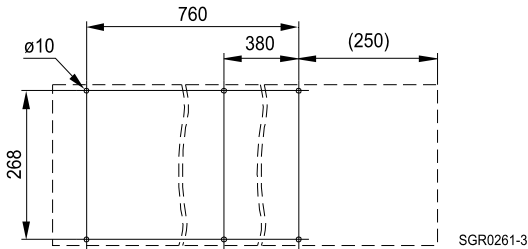
Fixing dimensions

The cable glands (with cutout sealing ring) are suitable for the following overall cable diameter:

PG 29	17 to 19 mm	20 to 22 mm	23 to 25 mm	26 to 28 mm
PG 21	9 to 11 mm	12 to 14 mm	15 to 17 mm	18 to 20 mm

RF-tight connection to shielding wall with connector fitting, see page 16.

Dimensional drawing 8 (direct connection to shielding wall)
4 x 40 A

B84263D1400E003

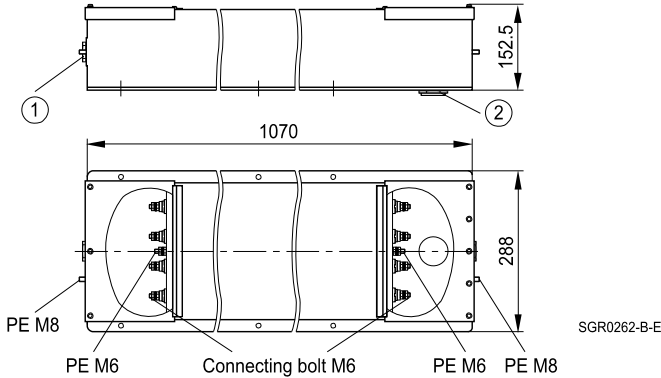

- ① Input end: Cable gland PG 29/21
(PG 29 mounted, PG 21 and reducer ring in accessory bag)
- ② Shielded end: Cable gland PG 29/21
(cable gland PG 29, PG 21 and reducer ring in accessory bag)

Paint color: RAL 7035 (light gray, semigloss)

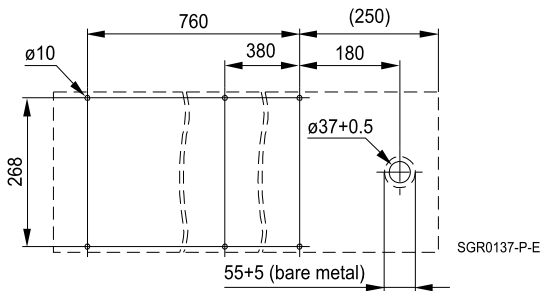
Fixing dimensions

The cable glands (with cutout sealing ring) are suitable for the following overall cable diameter:

PG 29	17 to 19 mm	20 to 22 mm	23 to 25 mm	26 to 28 mm
PG 21	9 to 11 mm	12 to 14 mm	15 to 17 mm	18 to 20 mm

RF-tight connection to shielding wall, see page 16.

Dimensional drawing 9 (cable glands at both ends)
4 x 100 A

B84263C1101E003

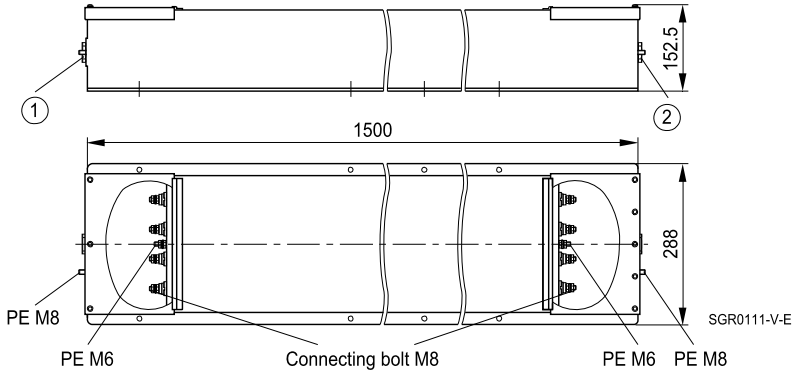

- ① Input end: Cable gland PG 42/29
(PG 42 mounted, PG 29 and reducer ring in accessory bag)
- ② Shielded end: Cable gland PG 42/29
(cable gland PG 42, PG 29 and reducer ring in accessory bag)

Paint color: RAL 7035 (light gray, semigloss)

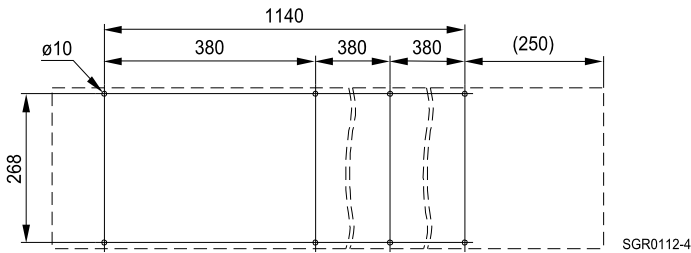
Fixing dimensions

The cable glands (with cutout sealing ring) are suitable for the following overall cable diameter:

PG 42	29 to 31 mm	32 to 34 mm	35 to 37 mm	38 to 40 mm
PG 29	17 to 19 mm	20 to 22 mm	23 to 25 mm	26 to 28 mm

RF-tight connection to shielding wall with connector fitting, see page 16.

Dimensional drawing 10 (direct connection to shielding wall)
4 x 100 A

B84263D1101E003

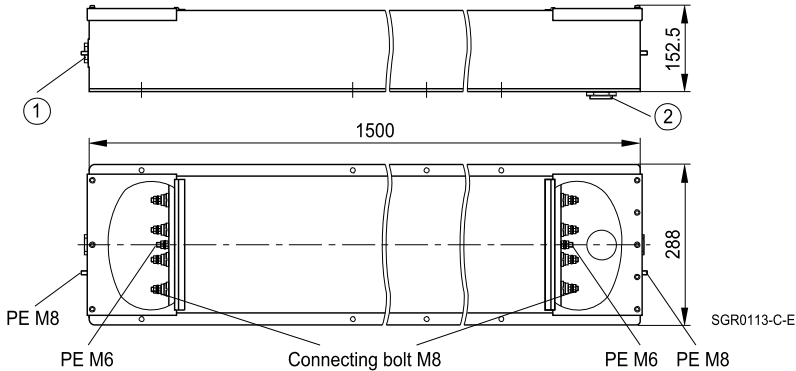

- ① Input end: Cable gland PG 42/29
(PG 42 mounted, PG 29 and reducer ring in accessory bag)
- ② Shielded end: Cable gland PG 42/29
(cable gland PG 42, PG 29 and reducer ring in accessory bag)

Paint color: RAL 7035 (light gray, semigloss)

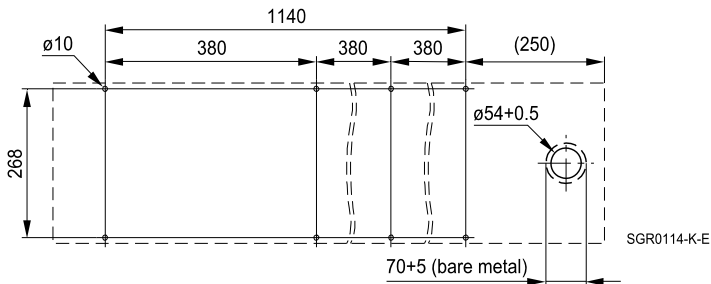
Fixing dimensions

The cable glands (with cutout sealing ring) are suitable for the following overall cable diameter:

PG 42	29 to 31 mm	32 to 34 mm	35 to 37 mm	38 to 40 mm
PG 29	17 to 19 mm	20 to 22 mm	23 to 25 mm	26 to 28 mm

RF-tight connection to shielding wall, see page 16.

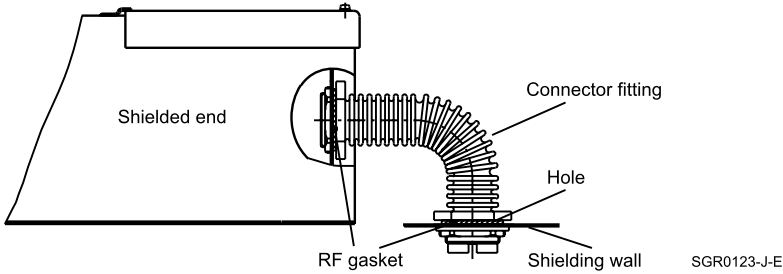
RF-tight connection to shielding wall with connector fitting (mechanical version C)

Cable gland	Connector fitting (must be ordered separately)	Ordering code	Hole in shielding wall	Bare metal area on shielding wall
PG 29	Nominal width 25 mm	B84298A0042L***	∅ 37 +0.5 mm	∅ 55 +5 mm
PG 42	Nominal width 40 mm	B84298A0044L***	∅ 54 +0.5 mm	∅ 70 +5 mm

(***: add required length in cm (see also chapter "Installation accessories").

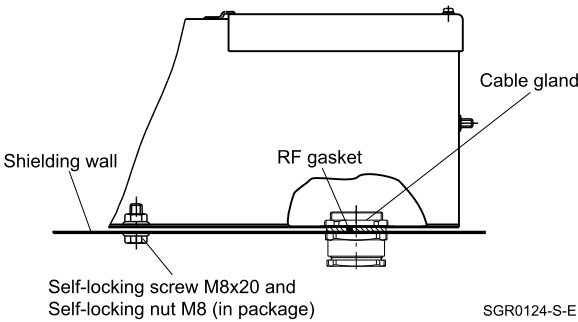
RF-tight connection to shielding wall (mechanical version D)

Cable gland	Parts for RF-tight mounting (in accessory bag)	Required hole in shielding wall	Bare metal area on shielding wall
PG 21	Suitable cable gland with long thread, RF gasket and check nut.	∅ 37 +0.5 mm	∅ 55 +5 mm
PG 29		∅ 54 +0.5 mm	∅ 70 +5 mm
PG 42			

Important notes

The following applies to all products named in this publication:

1. Some parts of this publication contain **statements about the suitability of our products for certain areas of application**. These statements are based on our knowledge of typical requirements that are often placed on our products in the areas of application concerned. We nevertheless expressly point out **that such statements cannot be regarded as binding statements about the suitability of our products for a particular customer application**. As a rule we are either unfamiliar with individual customer applications or less familiar with them than the customers themselves. For these reasons, it is always ultimately incumbent on the customer to check and decide whether a product with the properties described in the product specification is suitable for use in a particular customer application.
2. We also point out that **in individual cases, a malfunction of electronic components or failure before the end of their usual service life cannot be completely ruled out in the current state of the art, even if they are operated as specified**. In customer applications requiring a very high level of operational safety and especially in customer applications in which the malfunction or failure of an electronic component could endanger human life or health (e.g. in accident prevention or life-saving systems), it must therefore be ensured by means of suitable design of the customer application or other action taken by the customer (e.g. installation of protective circuitry or redundancy) that no injury or damage is sustained by third parties in the event of malfunction or failure of an electronic component.
3. **The warnings, cautions and product-specific notes must be observed.**
4. In order to satisfy certain technical requirements, **some of the products described in this publication may contain substances subject to restrictions in certain jurisdictions (e.g. because they are classed as hazardous)**. Useful information on this will be found in our Material Data Sheets on the Internet (www.tdk-electronics.tdk.com/material). Should you have any more detailed questions, please contact our sales offices.
5. We constantly strive to improve our products. Consequently, **the products described in this publication may change from time to time**. The same is true of the corresponding product specifications. Please check therefore to what extent product descriptions and specifications contained in this publication are still applicable before or when you place an order.

We also **reserve the right to discontinue production and delivery of products**. Consequently, we cannot guarantee that all products named in this publication will always be available. The aforementioned does not apply in the case of individual agreements deviating from the foregoing for customer-specific products.
6. Unless otherwise agreed in individual contracts, **all orders are subject to our General Terms and Conditions of Supply**.
7. **Our manufacturing sites serving the automotive business apply the IATF 16949 standard**. The IATF certifications confirm our compliance with requirements regarding the quality management system in the automotive industry. Referring to customer requirements and customer specific requirements ("CSR") TDK always has and will continue to have the policy of respecting individual agreements. Even if IATF 16949 may appear to support the acceptance of unilateral requirements, we hereby like to emphasize that **only requirements mutually agreed upon can and will be implemented in our Quality Management System**. For clarification purposes we like to point out that obligations from IATF 16949 shall only become legally binding if individually agreed upon.
8. The trade names EPCOS, CeraCharge, CeraDiode, CeraLink, CeraPad, CeraPlas, CSMP, CTVS, DeltaCap, DigiSiMic, ExoCore, FilterCap, FormFit, LeaXield, MiniBlue, MiniCell, MKD, MKK, MotorCap, PCC, PhaseCap, PhaseCube, PhaseMod, PhiCap, PowerHap, PQSine, PQvar, SIFERRIT, SIFI, SIKOREL, SilverCap, SIMDAD, SiMic, SIMID, SineFormer, SIOV, ThermoFuse, WindCap are **trademarks registered or pending** in Europe and in other countries. Further information will be found on the Internet at www.tdk-electronics.tdk.com/trademarks.

Mouser Electronics

Authorized Distributor

Click to View Pricing, Inventory, Delivery & Lifecycle Information:

[EPCOS / TDK:](#)

[B84263C22E13](#) [B84263D22B13](#) [B84263C22B13](#) [B84263D23B13](#) [B84263C23B13](#)