

DESCRIPTION: QUICK RELEASE - CONNECTOR POST OPTIONS

MATERIAL CHARACTERISTICS

POST: STEEL, TIN PLATED
 FLAT WASHER: STAINLESS STEEL
 LOCK WASHER: STAINLESS STEEL
 M3 NUT: STEEL, TIN PLATED

QUICK RELEASE POST KIT								
KIT PART NUMBER	QUANTITY IN KIT				QLOCK POST DIMENSIONS (IN)			
	①	②	③	④	A	K	L	M
QLOCK POST-1	2	2	4	2	0.276	0.118	0.787	0.394
QLOCK POST-2	2	2	4	2	0.236	0.118	0.748	0.394
QLOCK POST-3	2	4	4	2	0.197	0.118	0.630	0.315
QLOCK POST-5	2	4	4	2	0.189	0.118	0.701	0.394
QLOCK POST-6	2	2	4	2	0.189	0.118	0.701	0.394

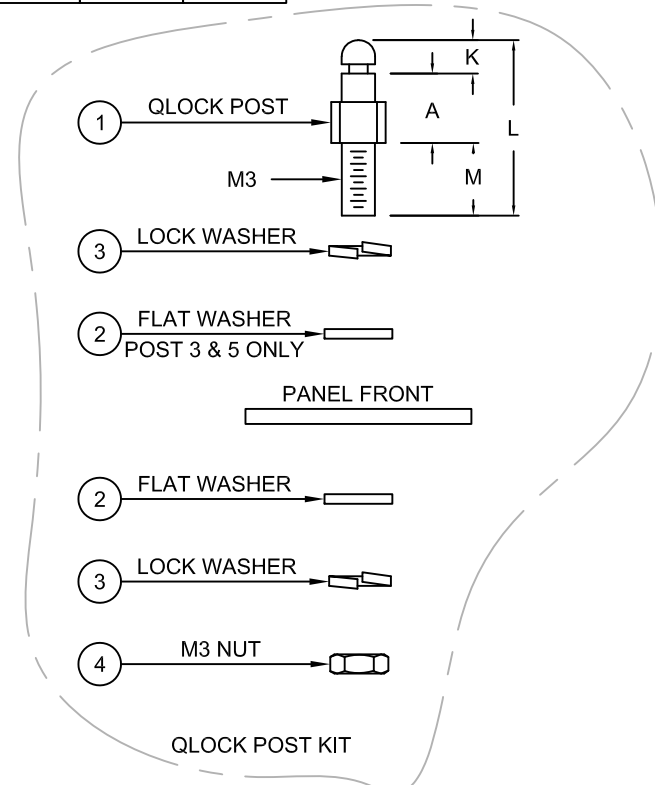
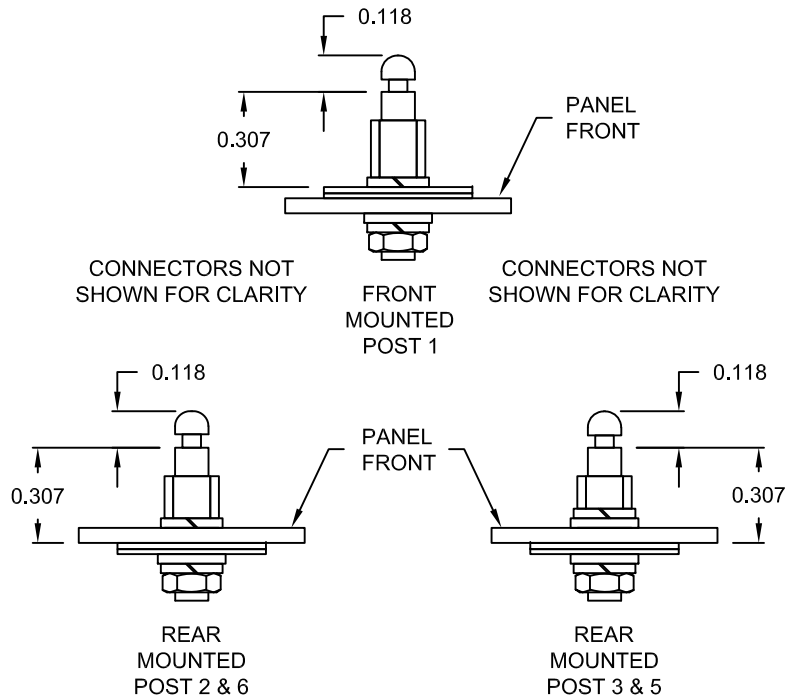

UNITS = INCH DO NOT SCALE FROM DRAWING

	THESE DRAWINGS AND SPECIFICATIONS ARE THE PROPERTY OF NorComp AND SHALL NOT BE REPRODUCED, COPIED OR USED AS THE BASIS FOR THE MANUFACTURE OF SALE OF APPARATUS WITHOUT WRITTEN PERMISSION.		DRAWN: C. SMITH	DATE: 04-10-07
	NorComp		SCALE: NTS	SHEET 1 OF 2
DWG NO. QLOCK POST-Y				

RoHS COMPLIANT

DESCRIPTION: QUICK RELEASE - CONNECTOR POST OPTIONS

KIT PART NUMBER	PANEL THICKNESS	MOUNT LOCATION
	(P)	
QLOCK POST-1	0.118 MAX	FRONT
QLOCK POST-2	0.039-0.051	REAR
QLOCK POST-3	0.059-0.071	REAR
QLOCK POST-5	0.067-0.079	REAR
QLOCK POST-6	0.087-0.098	REAR

		PANEL CUT OUT DIMENSIONS						
POSITIONS	LOCATION	A	B	C	D	E	F	G
9 STD / 15 H.D.	FRONT	0.984	0.492	0.874	0.437	0.513	0.257	0.083
	BACK	0.984	0.492	0.806	0.403	0.449	0.225	0.132
15 STD / 26 H.D.	FRONT	1.312	0.656	1.202	0.601	0.513	0.257	0.083
	BACK	1.312	0.656	1.134	0.567	0.449	0.225	0.132
25 STD / 44 H.D.	FRONT	1.852	0.926	1.743	0.872	0.513	0.257	0.083
	BACK	1.852	0.926	1.674	0.842	0.449	0.225	0.132
37 STD / 62 H.D.	FRONT	2.500	1.250	2.391	1.196	0.513	0.257	0.083
	BACK	2.500	1.250	2.326	1.163	0.449	0.225	0.132

UNITS = INCH

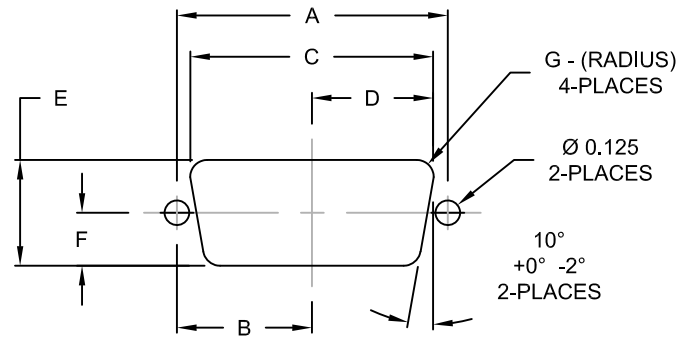
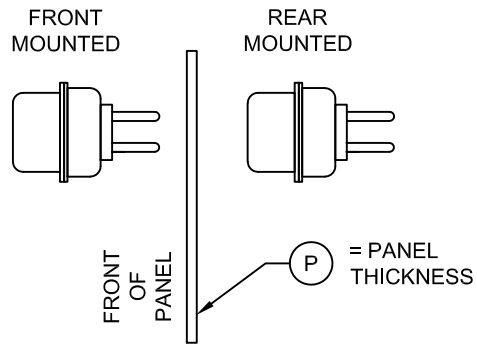

RECOMMENDED CUTOUT FRONT & BACK MOUNTING

DO NOT SCALE FROM DRAWING

	THESE DRAWINGS AND SPECIFICATIONS ARE THE PROPERTY OF NorComp AND SHALL NOT BE REPRODUCED, COPIED OR USED AS THE BASIS FOR THE MANUFACTURE OF SALE OF APPARATUS WITHOUT WRITTEN PERMISSION.		DRAWN: C. SMITH	DATE: 04-10-07
	<h1>NorComp</h1>		SCALE: NTS	SHEET 2 OF 2
DWG NO. QLOCK POST-Y				

RoHS COMPLIANT

Mouser Electronics

Authorized Distributor

Click to View Pricing, Inventory, Delivery & Lifecycle Information:

[NorComp:](#)

[QLOCKPOST-1](#) [QLOCKPOST-2](#) [QLOCKPOST-3](#) [QLOCKPOST-5](#) [QLOCKPOST-6](#) [QLOCKPOST-4](#)