

断面図 (参考)

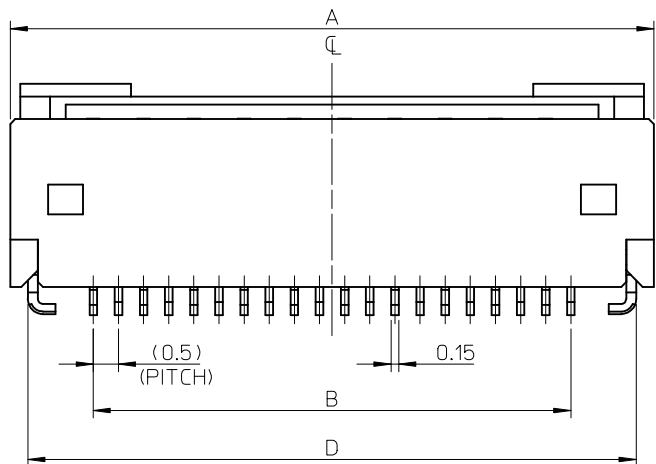
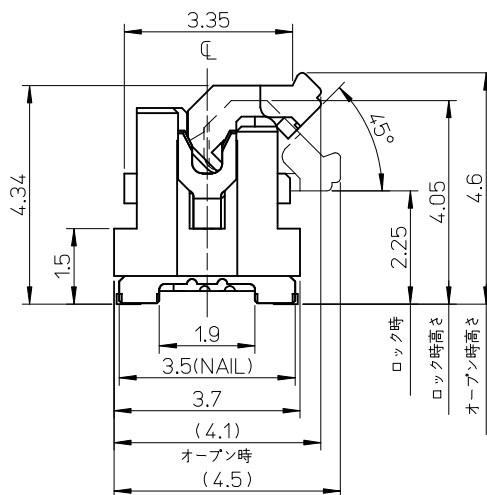

注記 NOTES

- 使用材料 MATERIAL
    - ハウジング : 液晶ポリマー ガラス充填, UL94V-0(白)
    - HOUSING : LIQUID CRYSTAL POLYMER GLASS FILLED, UL94V-0 (WHITE)
    - アクチュエータ : ポリアミド 9T, ガラス充填, UL94V-0(茶)
    - ACTUATOR : POLYAMIDE 9T, GLASS FILLED, UL94V-0 (BROWN)
    - ターミナル : 銅合金(t=0.15)
    - TERMINAL : COPPER ALLOY
    - 金具 : 銅合金(t=0.2)
    - FITTING NAIL : COPPER ALLOY
  - めっき仕様 PLATING
    - ターミナル TERMINAL
      - ニッケル下地銅ビスマスめっき
      - 銅ビスマスめっき(1.0μm以上)
      - ニッケルめっき(1.0μm以上)
      - TIN BISMUTH(SnBi) OVER NICKEL(Ni) PLATING.
      - TIN BISMUTH(SnBi) PLATING (1.0 MICROMETER MINIMUM)
      - NICKEL PLATING (1.0 MICROMETER MINIMUM)
    - 金具 FITTING NAIL
      - ニッケル下地銅めっき
      - 銅めっき(1.0μm以上)
      - ニッケルめっき(1.0μm以上)
      - TIN(Sn) OVER NICKEL(Ni) PLATING.
      - TIN PLATING (1.0 MICROMETER MINIMUM)
      - NICKEL PLATING (1.0 MICROMETER MINIMUM)
  - テールと金具を併せた平坦度は 0.1ミリメートル以下  
TAILS AND NAILS COPLANARITY TO BE 0.1 MAX.
  - ELV及びRoHS適合品  
ELV AND RoHS COMPLIANT
- △ R0.3は、FPC導体部にかからないこと。  
R0.3 MUST NOT BE OVERLAPPED TO PATTERN OF FPC.

8	30.7	32.1	32.4	29.5	32.8	501951-6009	60
	25.7	27.1	27.4	24.5	27.8	501951-5009	50
	23.2	24.6	24.9	22	25.3	501951-4509	45
	20.7	22.1	22.4	19.5	22.8	501951-4009	40
	16.7	18.1	18.4	15.5	18.8	501951-3209	32
	15.7	17.1	17.4	14.5	17.8	501951-3009	30
	12.7	14.1	14.4	11.5	14.8	501951-2409	24
	11.7	13.1	13.4	10.5	13.8	501951-2209	22
F	E	D	C	B	A	MATERIAL NO.	CIRCUITS

REVISED EC NO: J2015-0506 DRWN:NASUNUMA 2014/10/24 CHKD:KAKAHASHI 2014/11/10 APPR:YNOGAWA 2014/11/13	GENERAL TOLERANCES (UNLESS SPECIFIED)		DIMENSION STYLE MM ONLY	SCALE 10:1	DESIGN UNITS METRIC	THIRD ANGLE PROJECTION	
	10 UNDER	± 0.2	DRAWN BY TRSUZUKI	DATE 2005/12/05	TITLE 0.5 FPC CONN. HSG ASSY EASY ON / STRAIGHT (TIN-BISMUTH) <b>molex</b>		
	10 OVER 30 UNDER	± 0.25	CHECKED BY HHIRATA	DATE 2005/12/05			
	30 OVER	± 0.3	APPROVED BY MSASAO	DATE 2005/12/05			
ANGULAR ±1 °		MATERIAL NO.	DOCUMENT NO.				
DRAFT WHERE APPLICABLE MUST REMAIN WITHIN DIMENSIONS		SEE CHART		SD-501951-001		SHEET NO. 1 OF 2	
REV	DESCRIPTION		SIZE A3	THIS DRAWING CONTAINS INFORMATION THAT IS PROPRIETARY TO MOLEX INCORPORATED AND SHOULD NOT BE USED WITHOUT WRITTEN PERMISSION			

10 9 8 7 6 5 4 3 2 1

F

E

D

C

B

A

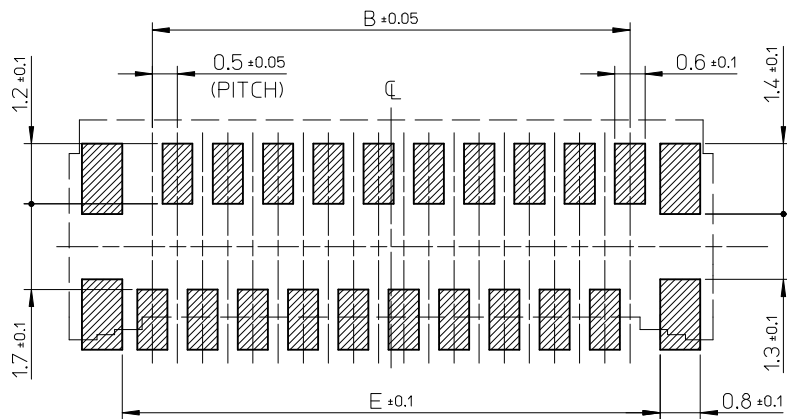

参考基板レイアウト (マウント面)

P.C.BOARD PATTERN DIMENSION(REF.)  
(MOUNT AREA)

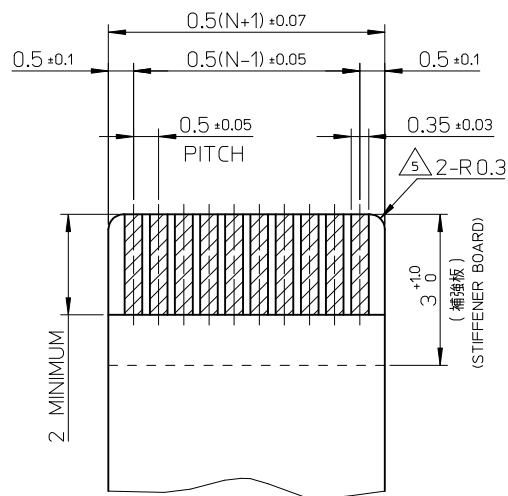

適合FPC推奨寸法  
APPLICABLE FPC  
RECOMMENDED DIMENSION  
(仕上がり厚さ: 0.3 ± 0.03)  
(THICKNESS: 0.3 ± 0.03)

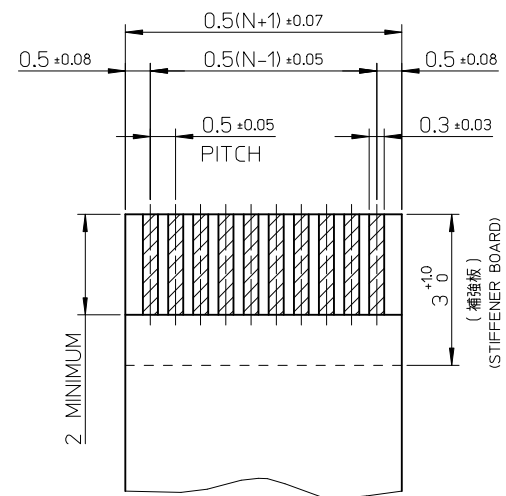

適合FFC推奨寸法  
APPLICABLE FFC  
RECOMMENDED DIMENSION  
(仕上がり厚さ: 0.3 ± 0.03)  
(THICKNESS: 0.3 ± 0.03)

FPCについて:

- 打抜き方向は導体側から補強板側を推奨致します。
- 補強フィルム材質はポリイミドを推奨致します。
- 接着剤は熱硬化接着剤を推奨致します。

ABOUT FPC:

- RECOMMENDED PUNCHER DIRECTION:  
FROM CONDUCTOR SIDE TO STIFFENER BOARD SIDE.
- RECOMMENDED MATERIAL:  
STIFFENER FILM: POLYIMIDE  
BONDING AGENT: THERMOSETTING BONDING AGENT

SEE SHEET 1 OF 2 EC NO: J2015-0506 DRAWN: IDRM/NASUNUMA 2014/10/21 CHECKED: CHKD/KTAKAHASHI 2014/11/10 APPR: YNDGAWA 2014/11/13	GENERAL TOLERANCES (UNLESS SPECIFIED)		DIMENSION STYLE MM ONLY		SCALE 10:1	DESIGN UNITS METRIC	THIRD ANGLE PROJECTION
	10 UNDER	± 0.2	DRAWN BY TRSUZUKI	DATE 2005/12/05	TITLE 0.5 FPC CONN. HSG ASSY EASY ON / STRAIGHT (TIN-BISMUTH)		
	10 OVER 30 UNDER	± 0.25	CHECKED BY HIRATA	DATE 2005/12/05			
	30 OVER	± 0.3	APPROVED BY MSASAO	DATE 2005/12/05			
ANGULAR	± 1 °	MATERIAL NO. SEE SHEET 1 OF 2	DOCUMENT NO. SD-501951-001		SHEET NO. 2 OF 2		
DRAFT WHERE APPLICABLE MUST REMAIN WITHIN DIMENSIONS		SIZE A3	THIS DRAWING CONTAINS INFORMATION THAT IS PROPRIETARY TO MOLEX INCORPORATED AND SHOULD NOT BE USED WITHOUT WRITTEN PERMISSION				

9 8 7 6 5 4 3 2

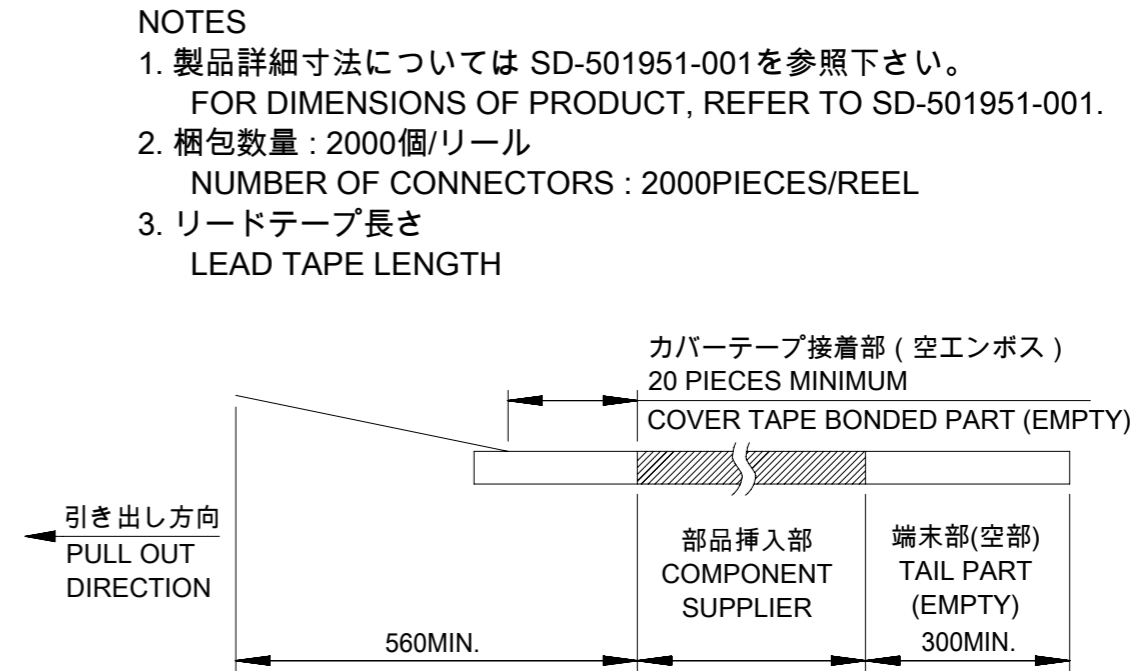
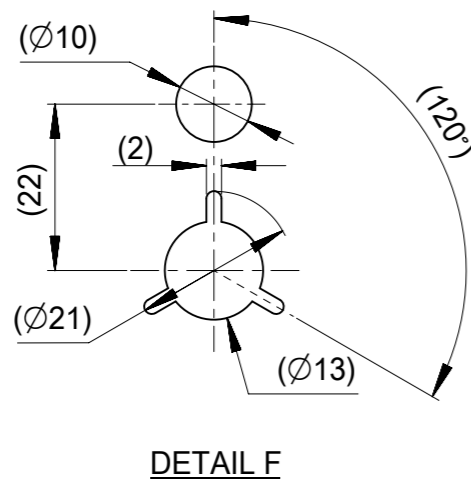
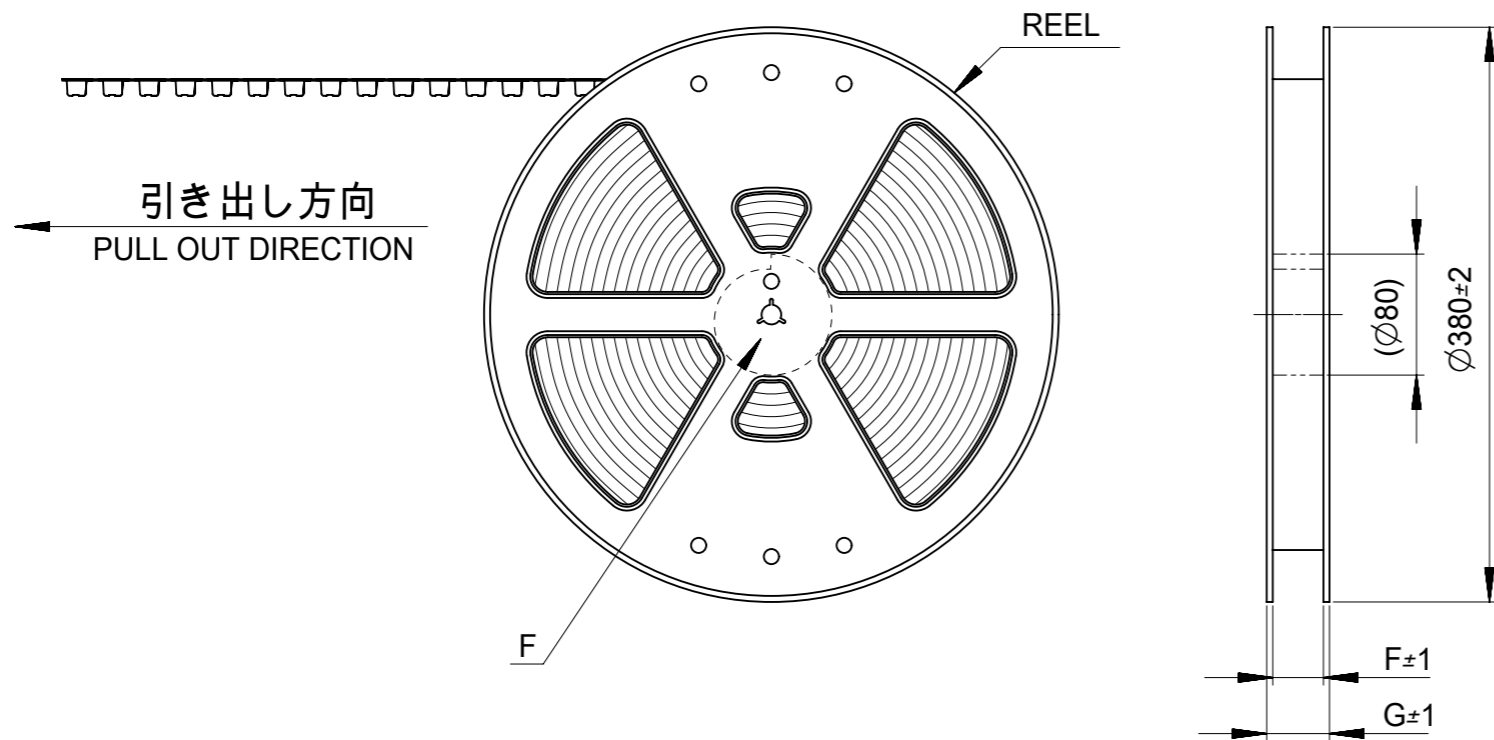

NOTES

- 製品詳細寸法については SD-501951-001を参照下さい。  
FOR DIMENSIONS OF PRODUCT, REFER TO SD-501951-001.
- 梱包数量 : 2000個/リール  
NUMBER OF CONNECTORS : 2000PIECES/REEL
- リードテープ長さ  
LEAD TAPE LENGTH
- カバーテープの剥離強度については、IEC60286-3に準拠。  
COVER TAPE PEEL FORCE IS DEFINED BY IEC60286-3.
- 材料 MATERIAL  
キャリアテープ : ポリスチレン  
CARRIER TAPE : POLYSTYRENE  
カバーテープ : ポリエチレンテレフタレート、ポリエチレン  
COVER TAPE : POLYETHYLENE TEREPHTHALATE , POLYETHYLENE  
リール : ポリスチレン<リサイクル材を含む>  
REEL : POLYSTYRENE<RECYCLE MATERIAL CONTAINED>
- ELV及びRoHS適合品  
ELV AND RoHS COMPLIANT

THIS DRAWING CONTAINS INFORMATION THAT IS PROPRIETARY TO MOLEX ELECTRONIC TECHNOLOGIES, LLC AND SHOULD NOT BE USED WITHOUT WRITTEN PERMISSION									
DIMENSION UNITS <b>mm</b>		SCALE <b>1:1</b>		CURRENT REV DESC:				<b>molex</b>	
GENERAL TOLERANCES (UNLESS SPECIFIED)				EC NO: 601584					
ANGULAR TOL ± 1.0 °				DRWN: SKAWAKAMI 2018/09/26				0.5 FPC CONN. HSG ASSY	
4 PLACES ± 0.25				CHK'D: TRSUZUKI 2018/12/25				E/O STRAIGHT EMBSTP PKG (TIN-BISMUTH)	
3 PLACES ± 0.25				APPR: RTAKEUCHI 2018/12/25				PRODUCT CUSTOMER DRAWING	
2 PLACES ± 0.25				INITIAL REVISION:				DOCUMENT NUMBER	
1 PLACE ± 0.25				DRWN: TRSUZUKI 2005/12/05				SD-501951-002	
0 PLACES ± 0.25				APPR: HHIRATA 2005/12/05				PSD 001 D	
DRAFT WHERE APPLICABLE MUST REMAIN WITHIN DIMENSIONS		THIRD ANGLE PROJECTION		DRAWING		SERIES		MATERIAL NUMBER	
				A3-SIZE		501951		SEE CHART	
						CUSTOMER		SHEET NUMBER	
						GENERAL		1 OF 2	

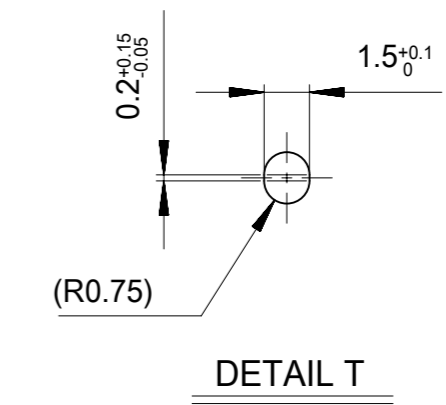
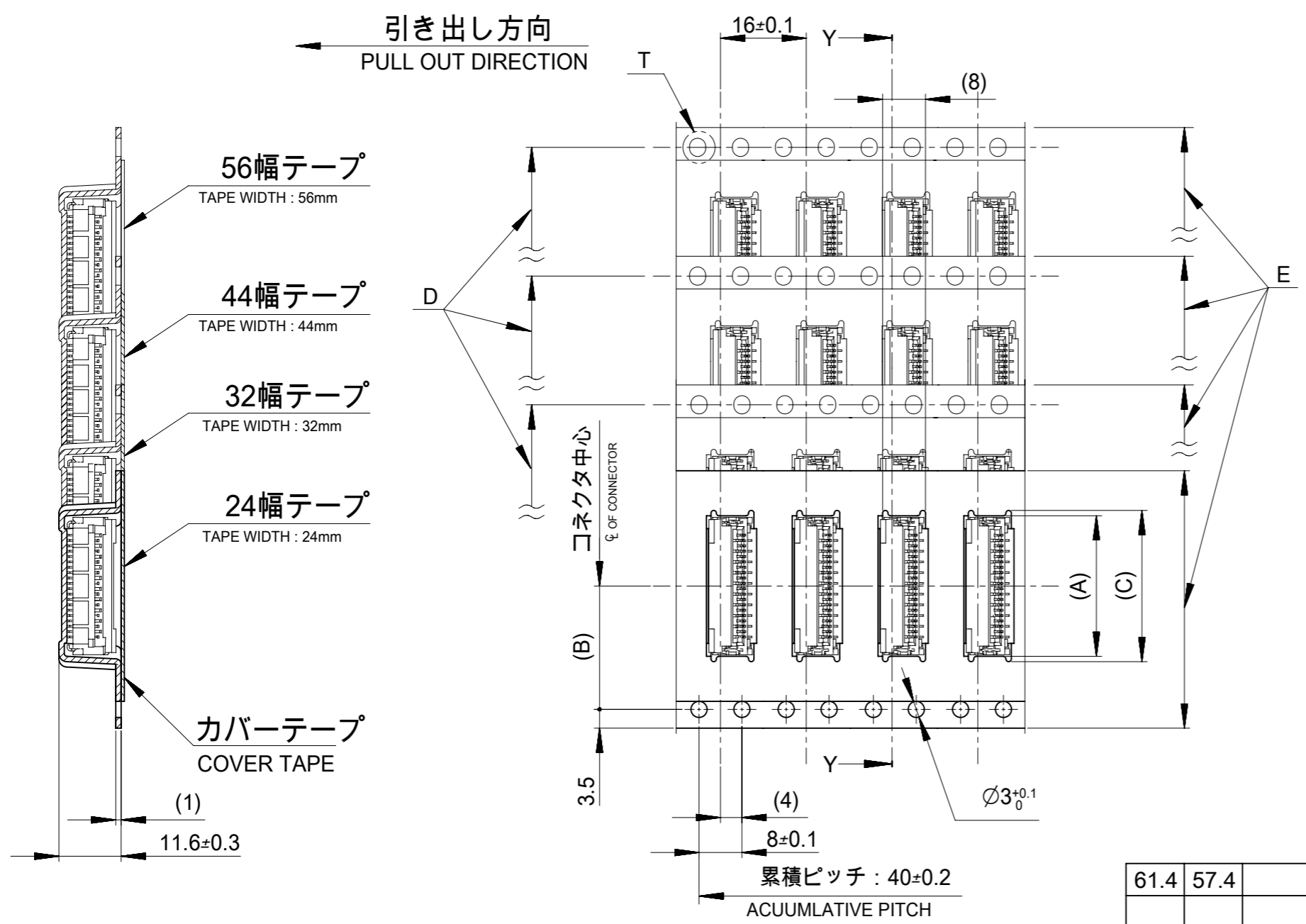

61.4	57.4	56±0.3	52.4	34.1	26.2	33.1	5019516000	60
49.4	45.4	44±0.3	40.4	29.1	20.2	28.1	5019515000	50
				26.6		25.6	5019514500	45
37.4	33.4	32±0.3	28.4	24.1	14.2	23.1	5019514000	40
				20.1		19.1	5019513200	32
				19.1		18.1	5019513000	30
29.4	25.4	24±0.3	-	15.1	11.5	15.1	5019512400	24
						14.1	5019512200	22
G	F	E CARRIER TAPE WIDTH	D	(C)	(B)	(A)	EMBOSSED PACKAGE ORDER NO.	CIRCUITS

THIS DRAWING CONTAINS INFORMATION THAT IS PROPRIETARY TO MOLEX ELECTRONIC TECHNOLOGIES, LLC AND SHOULD NOT BE USED WITHOUT WRITTEN PERMISSION

DIMENSION UNITS <b>mm</b>	SCALE <b>1:1</b>	CURRENT REV DESC:			<b>molex</b>		
GENERAL TOLERANCES (UNLESS SPECIFIED)		EC NO: 601584					
ANGULAR TOL	± 1.0 °	DRWN: SKAWAKAMI 2018/09/26			PRODUCT CUSTOMER DRAWING		
4 PLACES	± 0.25	CHK'D: TRSUZUKI 2018/12/25			DOCUMENT NUMBER		
3 PLACES	± 0.25	APPR: RTAKEUCHI 2018/12/25			SD-501951-002		
2 PLACES	± 0.25	INITIAL REVISION:			DOC TYPE	DOC PART	REVISION
1 PLACE	± 0.25	DRWN: TRSUZUKI 2005/12/05			PSD	001	D
0 PLACES	± 0.25	APPR: HHIRATA 2005/12/05			SHEET NUMBER		
DRAFT WHERE APPLICABLE MUST REMAIN WITHIN DIMENSIONS		THIRD ANGLE PROJECTION	DRAWING	SERIES	MATERIAL NUMBER	CUSTOMER	SHEET NUMBER
			A3-SIZE	501951	SEE CHART	GENERAL	2 OF 2

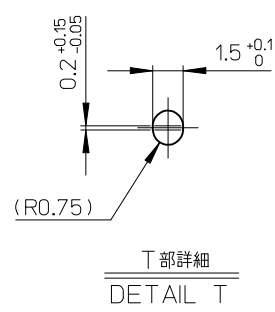
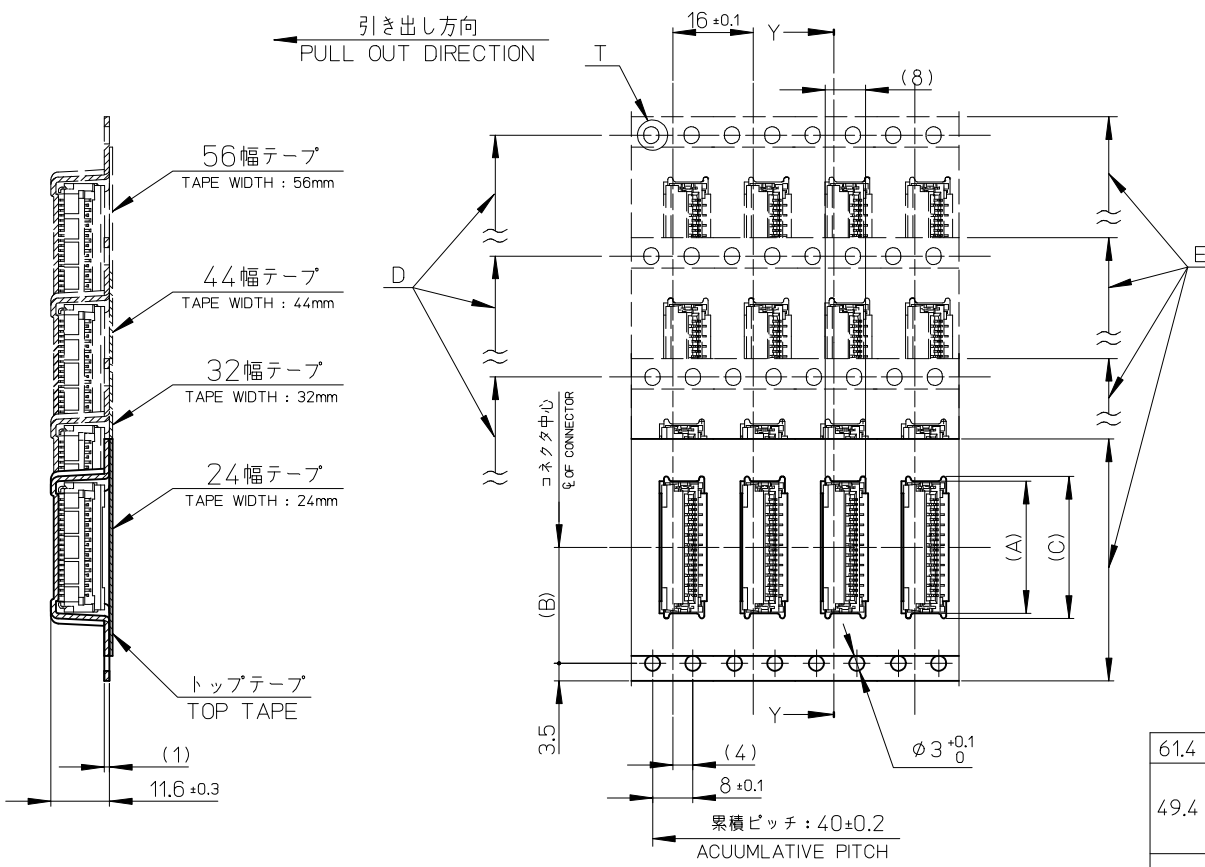

断面 Y-Y  
SECTION Y-Y

61.4	57.4	56±0.3	52.4	34.1	26.2	33.1	501951-6000	60
				29.1		28.1	501951-5000	50
49.4	45.4	44±0.3	40.4	26.6	20.2	25.6	501951-4500	45
				24.1		23.1	501951-4000	40
				20.1		19.1	501951-3200	32
37.4	33.4	32±0.3	28.4	19.1	14.2	18.1	501951-3000	30
				16.1		15.1	501951-2400	24
29.4	25.4	24±0.3	22.4	15.1	11.5	14.1	501951-2200	22
G	F	E キャリアテープ幅 CARRIER TAPE WIDTH	D	(C)	(B)	(A)	製品番号 MATERIAL NO.	極数 CIRCUITS

SEE SHEET 1 OF 2 EC NO: J2015-0506 DRWN: SANUMA 2014/10/21 CHKD: TAKAHASHI 2014/11/10 APPR: YNOGAWA 2014/11/13	GENERAL TOLERANCES (UNLESS SPECIFIED)		DIMENSION STYLE MM ONLY		SCALE ---	DESIGN UNITS METRIC	THIRD ANGLE PROJECTION	
	10 UNDER	±0.2	DRAWN BY TRSUZUKI	DATE 2005/12/05	TITLE 0.5 FPC CONN. HSG ASSY E/O STRAIGHT EMBSTP PKG (TIN-BISMUTH)			
	10 OVER 30 UNDER	±0.25	CHECKED BY HHRATA	DATE 2005/12/05				
	30 OVER	±0.3	APPROVED BY MSASAO	DATE 2005/12/05	molex SEE CHART SD-501951-002 DOCUMENT NO. 2 OF 2			
ANGULAR ±1 °		MATERIAL NO.						
DRAFT WHERE APPLICABLE MUST REMAIN WITHIN DIMENSIONS		SIZE A3		THIS DRAWING CONTAINS INFORMATION THAT IS PROPRIETARY TO MOLEX INCORPORATED AND SHOULD NOT BE USED WITHOUT WRITTEN PERMISSION				