

PART NUMBER	REVISION	DESCRIPTION	FEED TYPE
2151133-2	C	FINE CRIMP HEIGHT ADJUST	PNEUMATIC
7-2151133-2	C	PNEUMATIC AND CRIMP TOOLING KIT	PNEUMATIC
7-2151133-7	A	CRIMP TOOLING KIT	-

ATLANTIC VERSION TERMINATOR INTERFACE ADAPTER

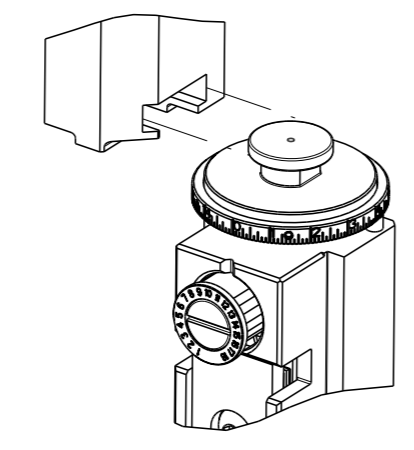

APPLICATOR DATA		
CRIMP	SIZE	TYPE
WIRE	2.03 mm [.080]	F
INSUL	2.79 mm [.110]	OV

APPLICATOR INSTRUCTIONS 408-35042

TERMINAL DATA: TE TERMINAL TE CRIMP SPECIFICATION			
TERMINAL NAME: STANDARD TIMER CONTACT			
WIRE STRIP LENGTH	INSULATION DIAMETER RANGE		
3.90-4.50 mm [.154-.177 IN]	Ø1.40-2.30 mm [.055-.091 IN]		
TERMINAL APPLICATION SPECIFICATION	(A)114-18079	-	-
	(B)114-18080	-	-

TERMINALS APPLIED			
TE TERMINAL	TE TERMINAL	TE TERMINAL	TE TERMINAL
(A) 927845-1	(B) 927847-1	(B) 928753-3	(B) 964201-2
(A) 927845-2	(B) 927847-2	(B) 928820-1	(B) 964201-3
(A) 927845-3	(B) 927847-3	(B) 928820-2	(B) 964201-4
(A) 927845-4	(B) 928753-1	(B) 928820-3	
(A) 927845-5	(B) 928753-2	(B) 964201-1	

WIRE SIZE	CRIMP HEIGHT mm [INCH]	CRIMP HEIGHT REFERENCE SETTING
1.00mm2	1.36+/-0.05 [0.054+/-0.002]	8.2
0.85mm2	1.31+/-0.05 [0.052+/-0.002]	8.7
18 AWG	1.29+/-0.05 [0.051+/-0.002]	9.0
0.75mm2	1.27+/-0.05 [0.050+/-0.002]	9.2
0.70mm2	1.25+/-0.05 [0.049+/-0.002]	9.3
20 AWG	1.19+/-0.05 [0.047+/-0.002]	10.4
0.50mm2	1.18+/-0.05 [0.046+/-0.002]	10.4

- 1 RECOMMENDED SPARE PARTS
- 2 REFER TO SUPPLIED INSTRUCTION SHEET FOR CLEANING, LUBRICATION AND STORAGE OF APPLICATOR.
- 3 APPLY PART NUMBER 2-23419-6 LOCTITE TO THREADS OF ITEM 242.
- 4 CRIMP HEIGHT REFERENCE SETTING WAS THE SETTING USED WHEN THE APPLICATOR WAS QUALIFIED AT THE FACTORY. ADJUSTMENT MAY BE NECESSARY WHEN RUNNING APPLICATOR IN THE FIELD.
- 5 TERMINAL PITCH NOT COMPATIBLE WITH MECHANICAL FEED.
- 6. UNLESS SPECIFIED OTHERWISE TORQUE VALUES SHALL BE USED PER DOCUMENT, 101-35000.

**\*WARNING**  
ON INSTALLATION, SET WIRE DISC TO CRIMP HEIGHT REFERENCE SETTING FOR LARGEST WIRE SIZE. CRIMP HEIGHT REFERENCE SETTINGS GREATER THAN THE VALUE SHOWN MAY CAUSE DAMAGE TO THE CRIMP TOOLING, REFER TO THE INSTRUCTION SHEET FOR PROPER SETUP AND ADJUSTMENTS.

LOC	DIST	REVISIONS					
		#	LYR	DESCRIPTION	DATE	OWN	APVD
A	66	A		RELEASE	12APR2012	L.Z	S.X
		A1		ECR-12-008623	10MAY2012	YY	SX
		B		ECR-14-000627	16JAN2014	KH	TE
		C		ECR-18-007838	22MAY2018	VLA	JDG

-	1	1	2119640-1	PUSH ROD, AIR FEED	250
-	1	1	1803259-1	BUSHING, FLANGED	249
-	1	1	2119641-1	FEED CAM, AIR FEED	248
-	1	1	2119082-9	CAM, SNAIL, INSULATION ADJUSTMENT	244
-	1	1	2079764-1	WASHER, WAVE SPRING, CREST-TO-CREST	243
-	1	1	2119083-1	RETAINER, INSULATION DIAL	242
-	1	1	7-18023-7	SCR, SKT HD CAP M3 X 4.0	241
-	1	1	2063440-1	AIR FEED MODULE	238
-	2	2	21045-3	RING, RETAIN, EXTERN, 3/16 CRESCENT	172
-	REF	REF	994970-2	COUNTER, MAGNETIC	164
-	1	1	240638-1	SPRING, FEED FINGER	163
-	1	1	3-23627-7	PIN, RETAIN, GRVD, 3/16 X .854	137
-	1	1	2119799-1	HOLDER, FEED FINGER, AF	136
-	1	1	1-18028-2	WASHER, FLAT, REG M4	119
-	1	1	2844908-1	SCREW, LOCKING	99
-	1	1	2844907-1	POST, LOCKING	98
-	1	1	455888-5	SPACER, CRIMPER	82
-	1	1	1803607-1	DOCUMENTATION PACKAGE	71
-	1	1	2119740-1	TAG, IDENTIFICATION	67
-	2	2	2168078-1	SCREW, DRIVE, RH, RoHS, 2 x .188	66
-	1	1	2168083-2	SCR, SKT HD CAP, RoHS, M4 X 8.0	60
-	1	1	5-18022-5	SCR, HEX HD CAP, M4 X 6.0	59
-	1	1	1338685-1	PAWL, FEED	56
-	4	4	2168083-3	SCR, SKT HD CAP, RoHS, M4 X 12.0	54
-	2	2	1-2168083-0	SCR, SKT HD CAP, RoHS, M4 X 10	53
-	1	1	1803382-6	HOLD DOWN, SPRING LOADED	50
-	1	1	18023-9	SCR, SKT HD CAP M4 X 6.0	49
-	1	1	1803583-9	APPLICATOR BASIC ASSEMBLY, SF	46
-	1	1	1803515-1	RAM ASSEMBLY, SF ATLANTIC	44
-	1	1	1803602-1	SCR, BHSC, RoHS (M8 X 25)	41
-	1	1	1752356-6	SUPPORT, TERMINAL	34
-	2	2	2079383-5	SCR, BHSC, RoHS (M4 X 20)	33
-	2	2	2-2844962-6	SPACER, CYLINDRICAL, STRIP GUIDE	30
-	1	1	2844992-1	ASSEMBLY, STRIP GUIDE	29
-	1	1	1-455888-0	SPACER, CRIMPER	28
-	1	1	1320928-2	STRIP GUIDE	24
-	1	1	2168083-2	SCR, SKT HD CAP, RoHS, M4 X 8.0	21
-	1	1	1-18028-2	WASHER, FLAT, REG M4	20
-	1	1	2119533-1	STRIPPER, SIDE FEED	19
-	1	1	2119806-1	INSERT, SHEAR	13
-	1	1	3-22280-3	SPRING, COMPRESSION	12
-	1	1	1-356885-4	STOP, SHEAR	11
-	1	1	2119805-1	SHEAR HOLDER, FRONT	10
-	1	1	1803095-1	FLOATING SHEAR, FRONT	9
-	1	2	1-1333204-0	ANVIL, COMBINATION	8
-	-	-	-	-	7
-	-	-	-	-	6
-	1	1	2119757-8	DEPRESSOR, SHEAR	5
-	1	1	1-238011-7	BLOCK, CRIMPER SPACER	4
-	1	2	1-2119785-0	CRIMPER, INSULATION OVERLAP PREMIUM	3
-	1	1	455888-5	SPACER, CRIMPER	2
-	1	2	1-456405-5	CRIMPER, WIRE PREMIUM	1

ATLANTIC VERSION  
Shown on sheets 1 of 4 & 2 of 4  
(Pacific version shown on sheets 3 of 4 & 4 of 4)

DIMENSIONS:		TOLERANCES UNLESS OTHERWISE SPECIFIED:		MATERIAL:		FINISH:		WEIGHT:		SCALE:		SHEET:		REV:				
mm	0 PLC ±	1 PLC ±	2 PLC ±	3 PLC ±	4 PLC ±	ANGLES	FINISH			Customer Accessible Production Drawing	SCALE	1:2	SHEET	1	OF	4	REV	C

LOC	DIST	REVISIONS			
		REV	DATE	OWN	APVD
A	66	1	SEE SHEET 1	-	-

# FEED TYPE

## PNEUMATIC

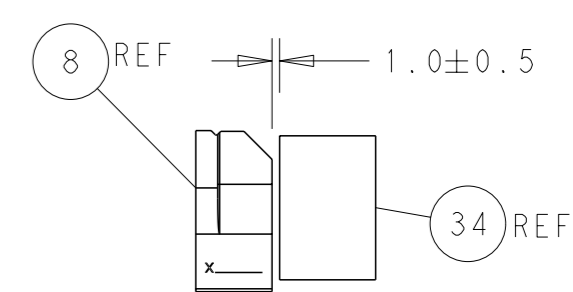
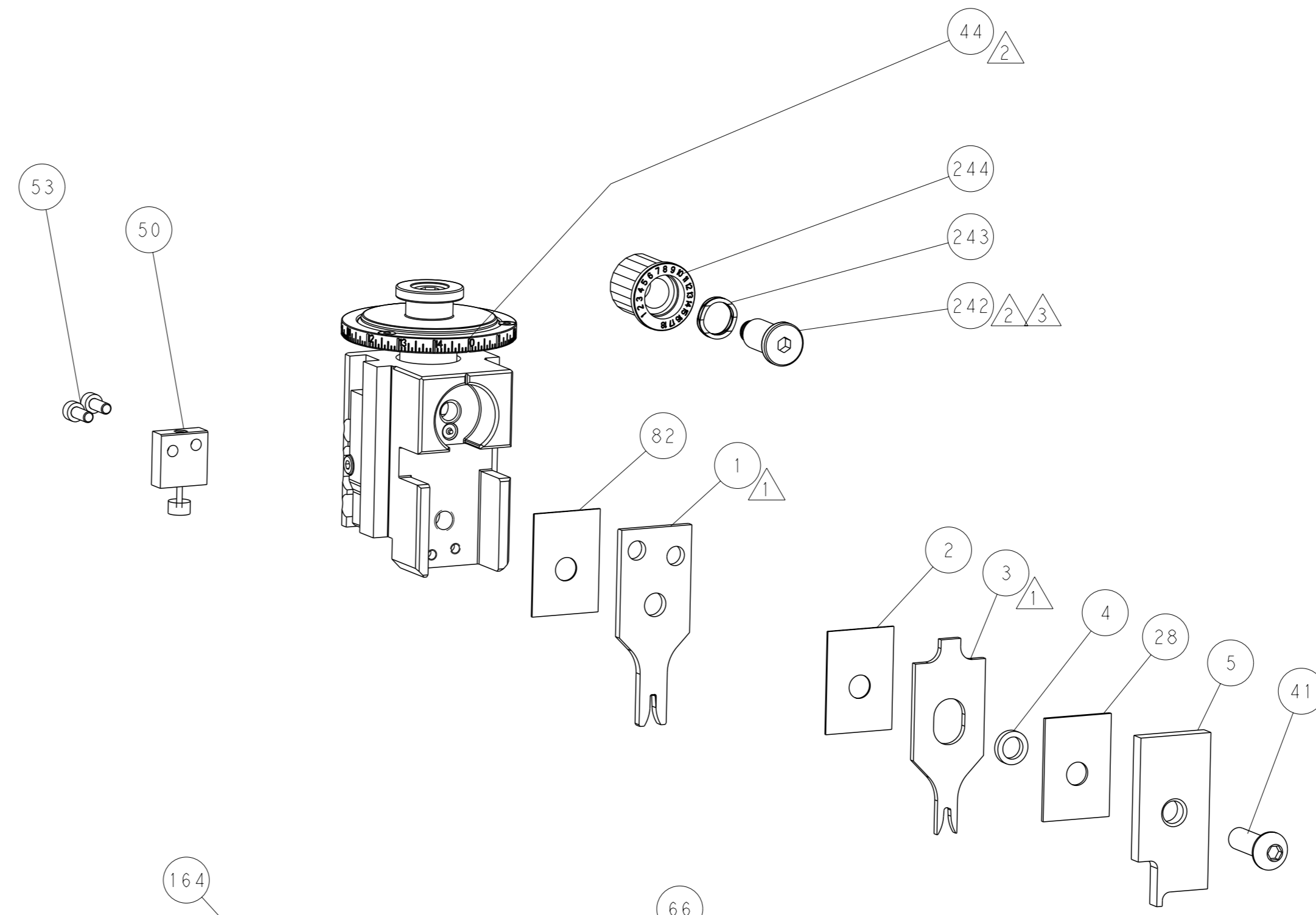
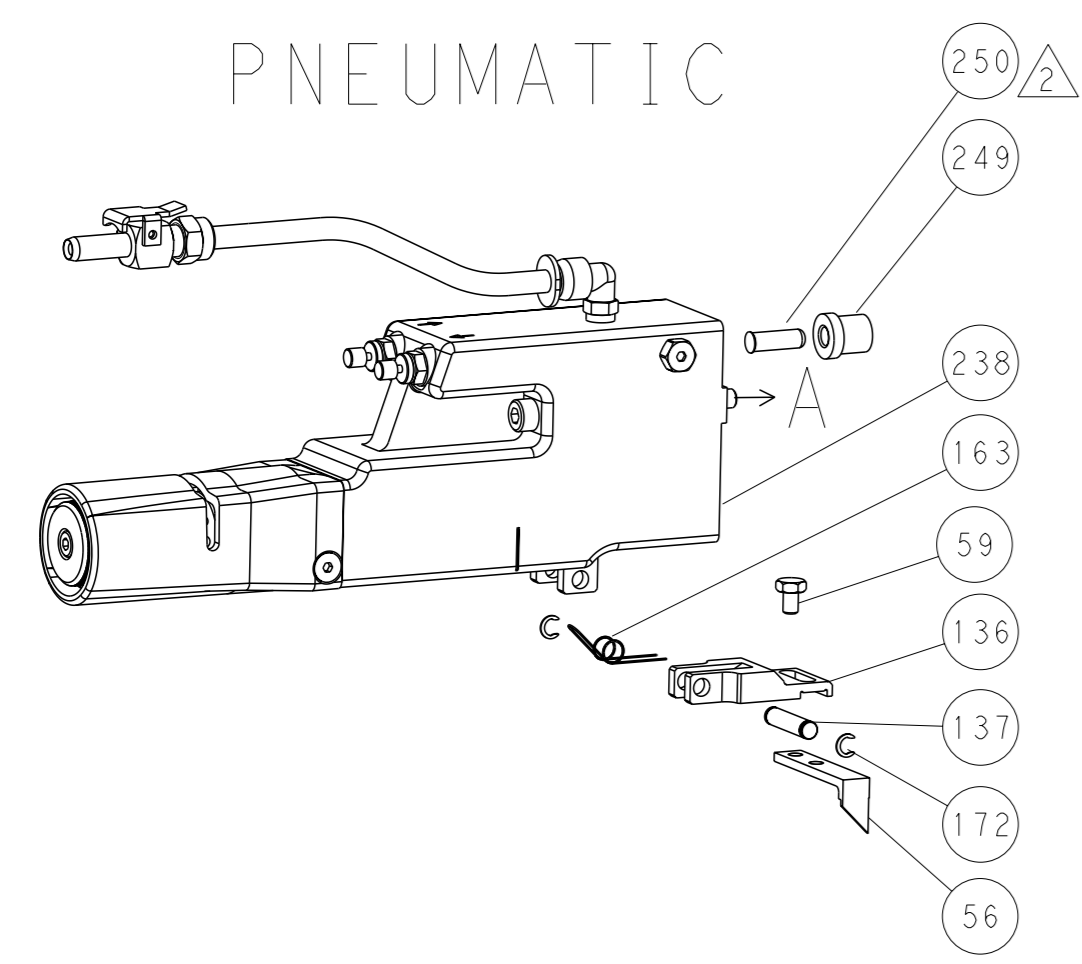

TERMINAL SUPPORT LOCATION

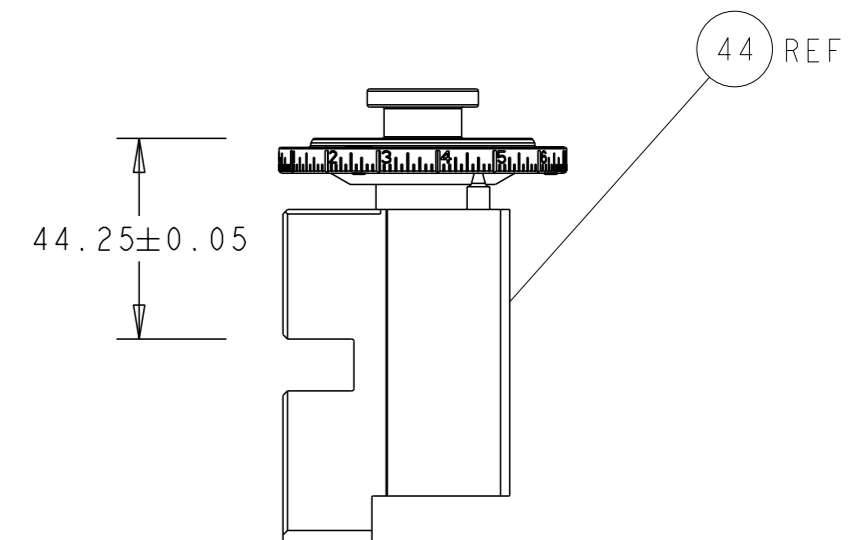

RAM SET-UP

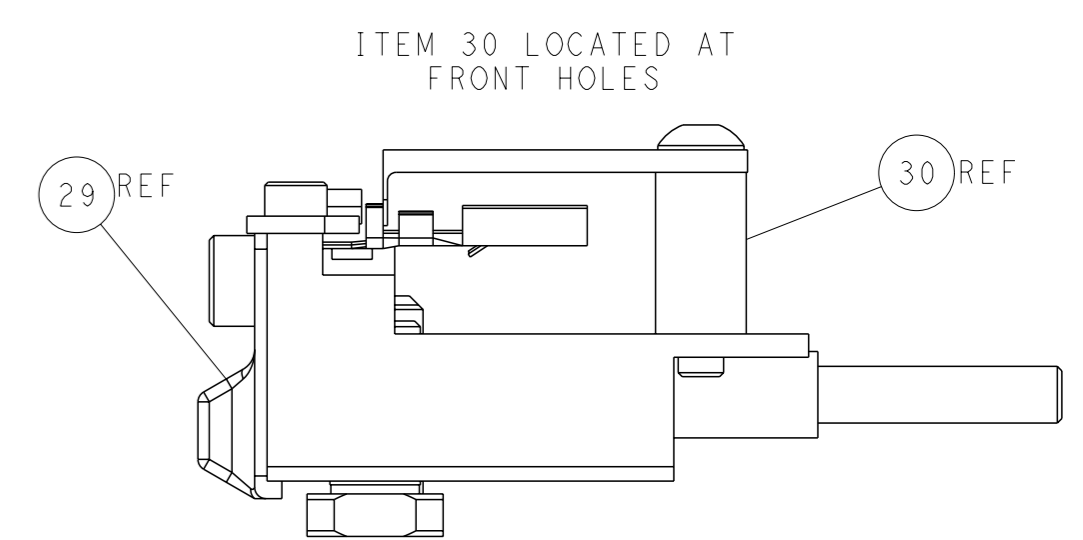
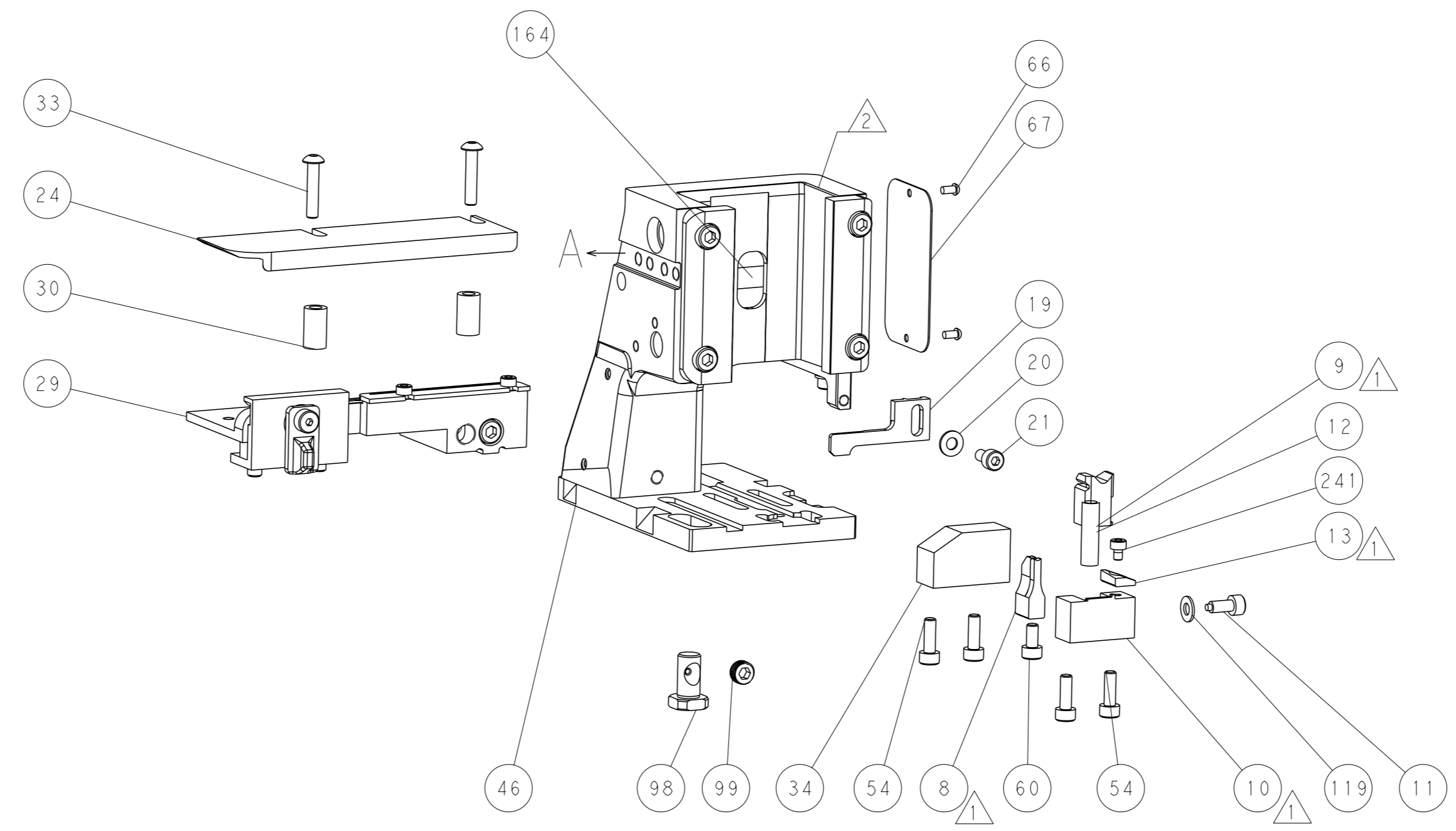

FEED TRACK POSITION GUIDE BY INSULATION BARREL

## CAM POSITION

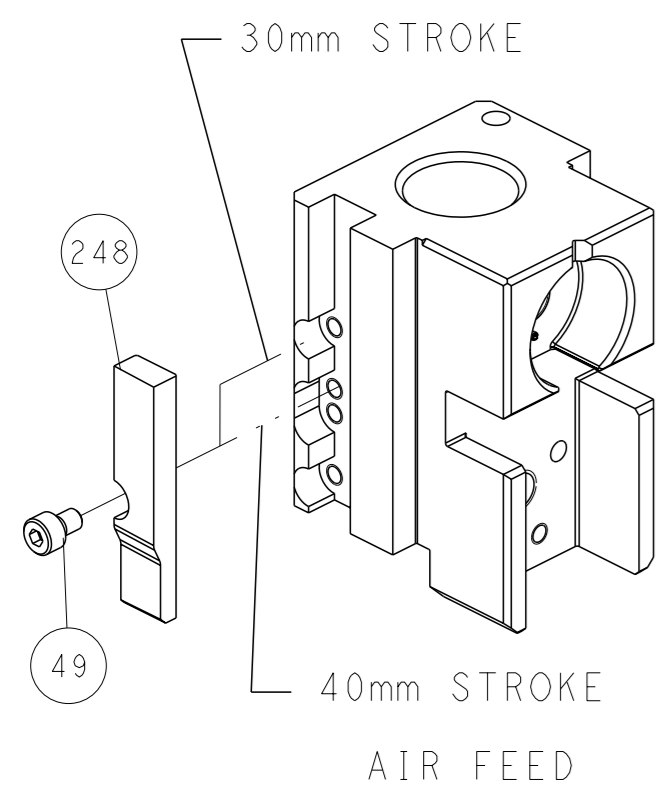

**ATLANTIC VERSION**  
 Shown on sheets 1 of 4 & 2 of 4  
 (Pacific version shown on sheets 3 of 4 & 4 of 4)

<small>THIS DRAWING IS A CONTROLLED DOCUMENT FOR TYCO ELECTRONICS CORPORATION. IT IS SUBJECT TO CHANGE AND TO CONTROLING ENGINEERING DISCRETION. SHOULD BE CONTACTED FOR THE LATEST REVISION.</small>		DWN Y. YIN 18OCT2011 CHK G. BAILEY 18OCT2011 APVD S. XI 18OCT2011	TE Connectivity Harrisburg, PA 17105-3608
DIMENSIONS: mm TOLERANCES UNLESS OTHERWISE SPECIFIED: 0 PLC ± 1 PLC ± 2 PLC ± 3 PLC ± 4 PLC ± ANGLES FINISH ±		NAME Ocean Side Feed Applicator SIZE CAGE CODE DRAWING NO. A1 00779 ©=2151133 WEIGHT - Customer Accessible Production Drawing	RESTRICTED TO - SCALE 1:2 SHEET 2 of 4 REV C

THIS DRAWING IS UNPUBLISHED.	RELEASED FOR PUBLICATION		
COPYRIGHT 20 BY TYCO ELECTRONICS CORPORATION. ALL RIGHTS RESERVED.			
PART NUMBER	REVISION	DESCRIPTION	FEED TYPE
2-2151133-2	C	FINE CRIMP HEIGHT ADJUST	PNEUMATIC
7-2151133-7	A	CRIMP TOOLING KIT	-

PACIFIC VERSION TERMINATOR  
INTERFACE ADAPTER

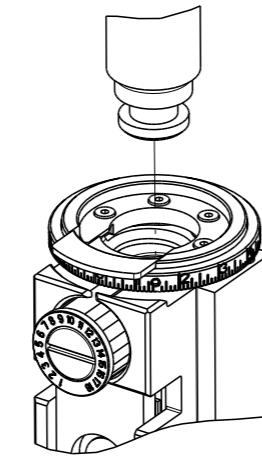

APPLICATOR DATA		
CRIMP	SIZE	TYPE
WIRE	2.03 mm [.080]	F
INSUL	2.79 mm [.110]	OV
APPLICATOR INSTRUCTIONS 408-35042		

TERMINAL DATA: TE TERMINAL		TE CRIMP SPECIFICATION	
TERMINAL NAME: STANDARD TIMER CONTACT			
WIRE STRIP LENGTH 3.90-4.50 mm [.154-.177 IN]		INSULATION DIAMETER RANGE Ø1.40-2.30 mm [.055-.091 IN]	
TERMINAL APPLICATION SPECIFICATION	(A)114-18079	-	-
	(B)114-18080	-	-
TERMINALS APPLIED			
TE TERMINAL	TE TERMINAL	TE TERMINAL	TE TERMINAL
(A) 927845-1	(B) 927847-1	(B) 928753-3	(B) 964201-2
(A) 927845-2	(B) 927847-2	(B) 928820-1	(B) 964201-3
(A) 927845-3	(B) 927847-3	(B) 928820-2	(B) 964201-4
(A) 927845-4	(B) 928753-1	(B) 928820-3	
(A) 927845-5	(B) 928753-2	(B) 964201-1	

WIRE SIZE	CRIMP HEIGHT mm [INCH]	CRIMP HEIGHT REFERENCE SETTING
1.00mm2	1.36+/-0.05 [.054+/-0.002]	8.2
0.85mm2	1.31+/-0.05 [.052+/-0.002]	8.7
18 AWG	1.29+/-0.05 [.051+/-0.002]	9.0
0.75mm2	1.27+/-0.05 [.050+/-0.002]	9.2
0.70mm2	1.25+/-0.05 [.049+/-0.002]	9.3
20 AWG	1.19+/-0.05 [.047+/-0.002]	10.4
0.50mm2	1.18+/-0.05 [.046+/-0.002]	10.4

**\*WARNING**  
ON INSTALLATION, SET WIRE DISC TO CRIMP HEIGHT REFERENCE SETTING FOR LARGEST WIRE SIZE. CRIMP HEIGHT REFERENCE SETTINGS GREATER THAN THE VALUE SHOWN MAY CAUSE DAMAGE TO THE CRIMP TOOLING, REFER TO THE INSTRUCTION SHEET FOR PROPER SETUP AND ADJUSTMENTS.

- RECOMMENDED SPARE PARTS
- REFER TO SUPPLIED INSTRUCTION SHEET FOR CLEANING, LUBRICATION AND STORAGE OF APPLICATOR.
- APPLY PART NUMBER 2-23419-6 LOCTITE TO THREADS OF ITEM 242.
- CRIMP HEIGHT REFERENCE SETTING WAS THE SETTING USED WHEN THE APPLICATOR WAS QUALIFIED AT THE FACTORY. ADJUSTMENT MAY BE NECESSARY WHEN RUNNING APPLICATOR IN THE FIELD.
- TERMINAL PITCH NOT COMPATIBLE WITH MECHANICAL FEED.
- UNLESS SPECIFIED OTHERWISE TORQUE VALUES SHALL BE USED PER DOCUMENT, 101-35000.

LOC	DIST	REV	DATE	OWN	APVD
A	66				

REV	DATE	DESCRIPTION	ITEM NO	
-	1	2119640-1 PUSH ROD, AIR FEED	250	
-	1	1803259-1 BUSHING, FLANGED	249	
-	1	2119082-9 CAM, SNAIL, INSULATION ADJUSTMENT	244	
-	1	2079764-1 WASHER, WAVE SPRING, CREST-TO-CREST	243	
-	1	2119083-1 RETAINER, INSULATION DIAL	242	
-	1	7-18023-7 SCR, SKT HD CAP M3 X 4.0	241	
-	1	2063440-1 AIR FEED MODULE	238	
-	2	21045-3 RING, RETAIN, EXTERN, 3/16 CRESCENT	172	
-	REF	994970-2 COUNTER, MAGNETIC	164	
-	1	240638-1 SPRING, FEED FINGER	163	
-	1	2119641-2 FEED CAM, AIR FEED	151	
-	1	2168083-8 SCR, SKT HD CAP, RoHS, M4 X 16	144	
-	4	2168083-9 SCR, SKT HD CAP, RoHS, M4 X 20	143	
-	1	1-1803583-0 APPLICATOR BASIC ASSEMBLY, SF	141	
-	1	1803516-1 RAM ASSEMBLY, SF PACIFIC	140	
-	1	3-23627-7 PIN, RETAIN, GRVD, 3/16 X .854	137	
-	1	2119799-1 HOLDER, FEED FINGER, AF	136	
-	1	1-18028-2 WASHER, FLAT, REG M4	119	
-	1	2844908-1 SCREW, LOCKING	99	
-	1	2844907-1 POST, LOCKING	98	
-	1	455888-5 SPACER, CRIMPER	82	
-	1	1803607-1 DOCUMENTATION PACKAGE	71	
-	1	2119740-1 TAG, IDENTIFICATION	67	
-	2	2168078-1 SCREW, DRIVE, RH, RoHS, 2 x .188	66	
-	1	5-18022-5 SCR, HEX HD CAP, M4 X 6.0	59	
-	1	1338685-1 PAWL, FEED	56	
-	2	1-2168083-0 SCR, SKT HD CAP, RoHS, M4 X 10	53	
-	1	1803382-6 HOLD DOWN, SPRING LOADED	50	
-	1	18023-9 SCR, SKT HD CAP M4 X 6.0	49	
-	1	1803602-1 SCR, BHSC, RoHS (M8 X 25)	41	
-	1	1752356-6 SUPPORT, TERMINAL	34	
-	2	2079383-5 SCR, BHSC, RoHS (M4 X 20)	33	
-	2	2-2844962-6 SPACER, CYLINDRICAL, STRIP GUIDE	30	
-	1	2844992-1 ASSEMBLY, STRIP GUIDE	29	
-	1	1-455888-0 SPACER, CRIMPER	28	
-	1	1320928-2 STRIP GUIDE	24	
-	1	2168083-2 SCR, SKT HD CAP, RoHS, M4 X 8.0	21	
-	1	1-18028-2 WASHER, FLAT, REG M4	20	
-	1	2119533-1 STRIPPER, SIDE FEED	19	
-	1	2119806-1 INSERT, SHEAR	13	
-	1	3-22280-3 SPRING, COMPRESSION	12	
-	1	1-356885-4 STOP, SHEAR	11	
-	1	2119805-1 SHEAR HOLDER, FRONT	10	
-	1	1803095-1 FLOATING SHEAR, FRONT	9	
-	1	1-1333204-0 ANVIL, COMBINATION	8	
-	-	-	7	
-	-	-	6	
-	1	2119757-8 DEPRESSOR, SHEAR	5	
-	1	1-238011-7 BLOCK, CRIMPER SPACER	4	
-	1	1-2119785-0 CRIMPER, INSULATION OVERLAP PREMIUM	3	
-	1	455888-5 SPACER, CRIMPER	2	
-	1	1-456405-5 CRIMPER, WIRE PREMIUM	1	
-77	-22	PART NO	DESCRIPTION	ITEM NO

PACIFIC VERSION  
Shown on sheets 3 of 4 & 4 of 4  
(Atlantic version shown on sheets 1 of 4 & 2 of 4)

DIMENSIONS: mm		TOLERANCES UNLESS OTHERWISE SPECIFIED:		DWG Y.YIN 18OCT2011		CHK G.BAILEY 18OCT2011		APVD S.XI 18OCT2011		NAME	
0 PLC ±		1 PLC ±		2 PLC ±		3 PLC ±		4 PLC ±		TE Connectivity Harrisburg, PA 17105-3608	
MATERIAL		FINISH		WEIGHT		SCALE		SHEET		REV	
						1:2		3 of 4		C	

Customer Accessible Production Drawing

LOC	DIST	REVISIONS			
A	66	REV	DATE	OWN	APVD
		-	SEE SHEET 1	-	-

# FEED TYPE

## PNEUMATIC

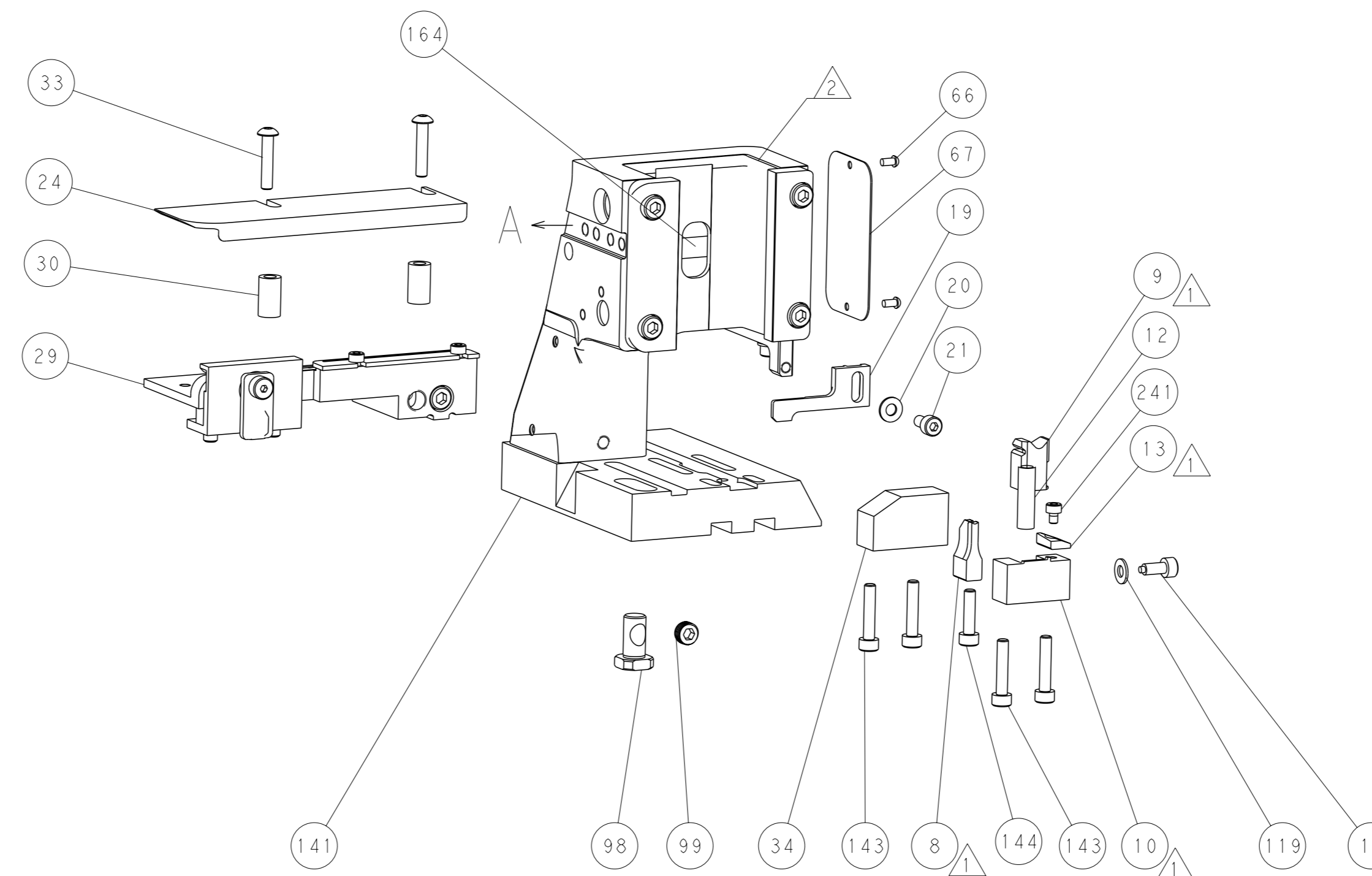
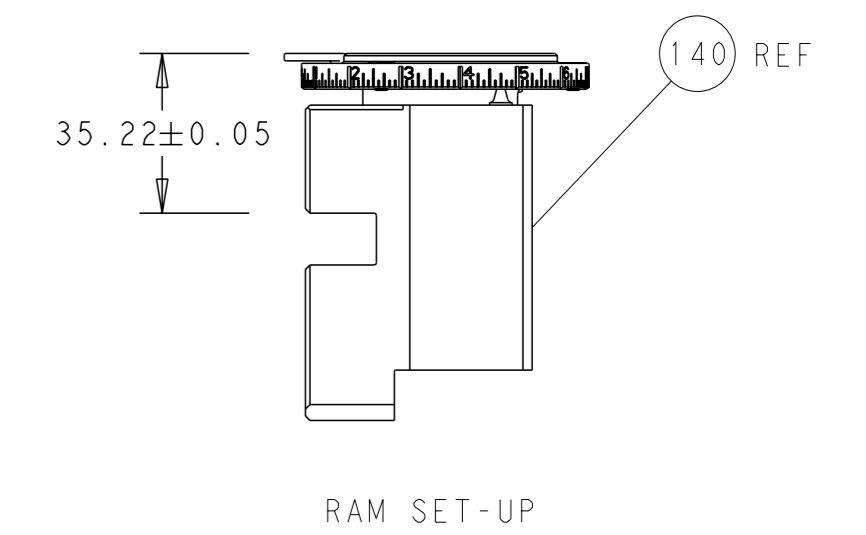
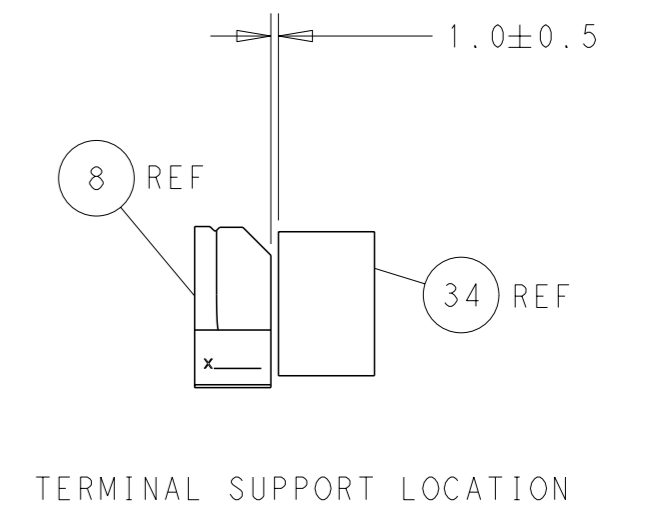
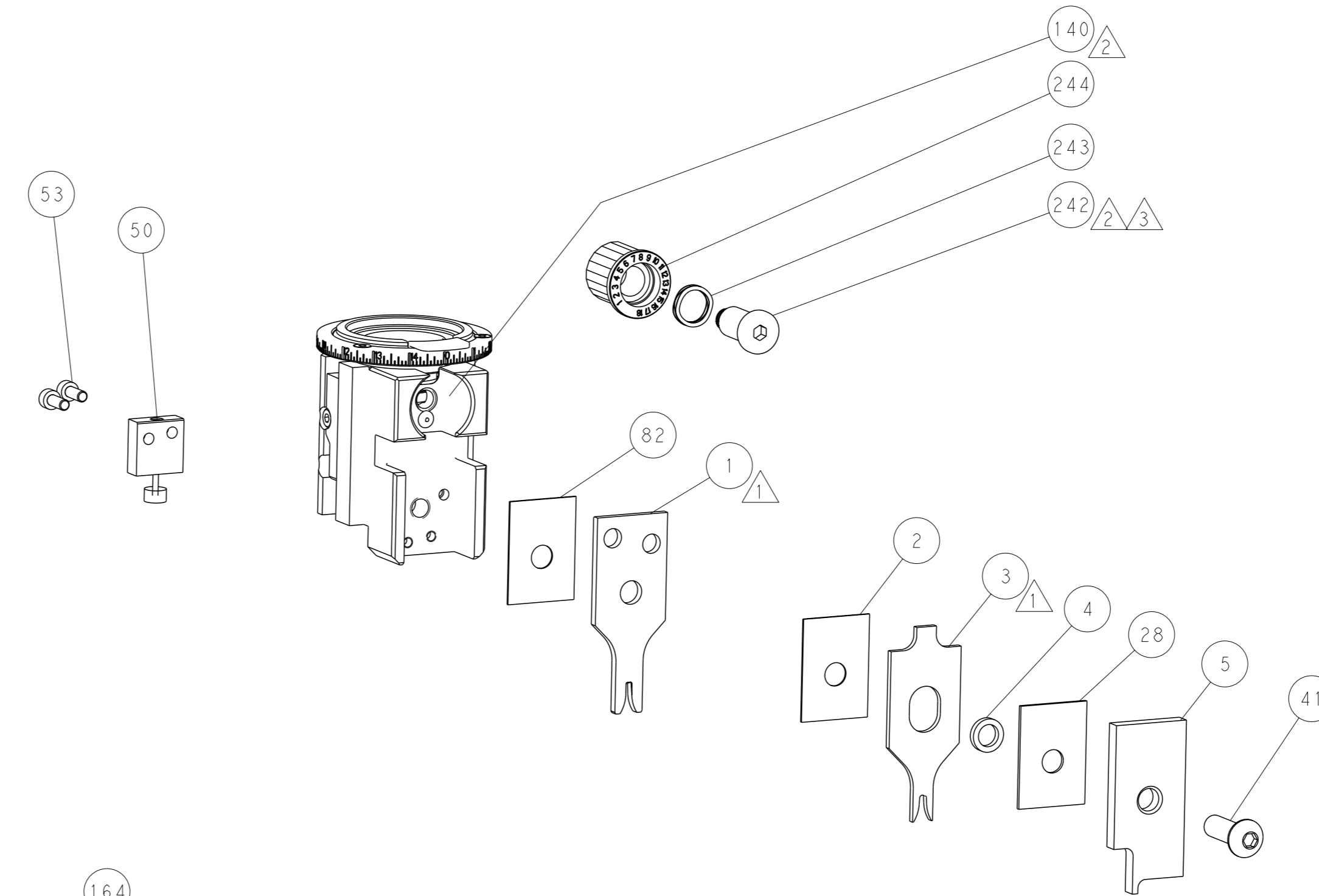
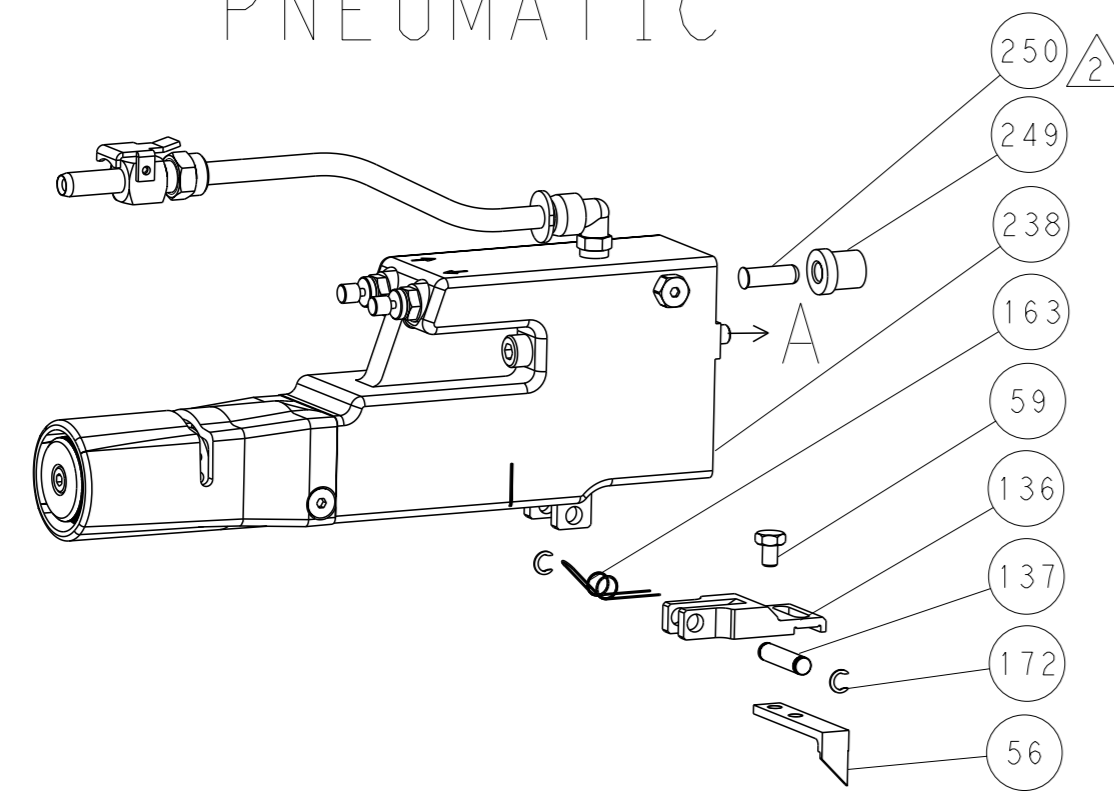

ITEM 30 LOCATED AT FRONT HOLES

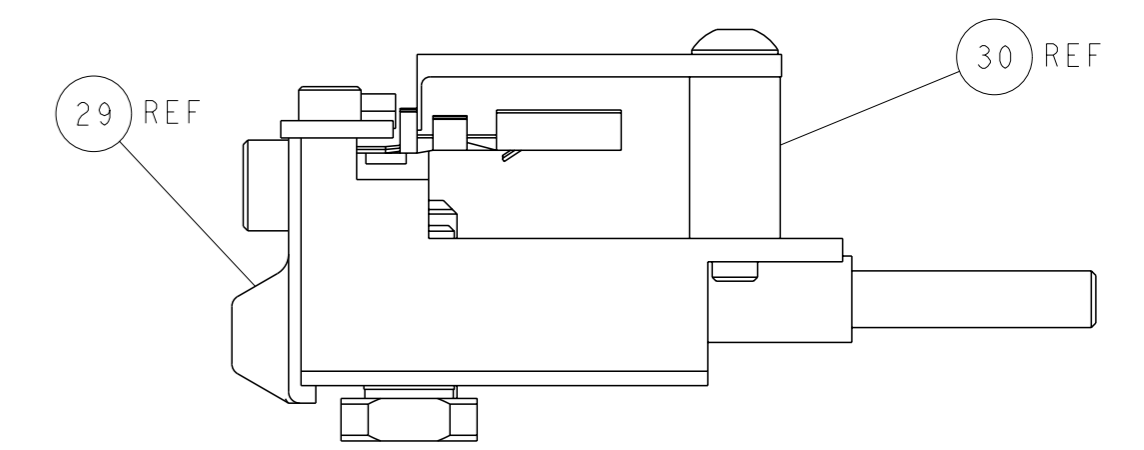

## CAM POSITION

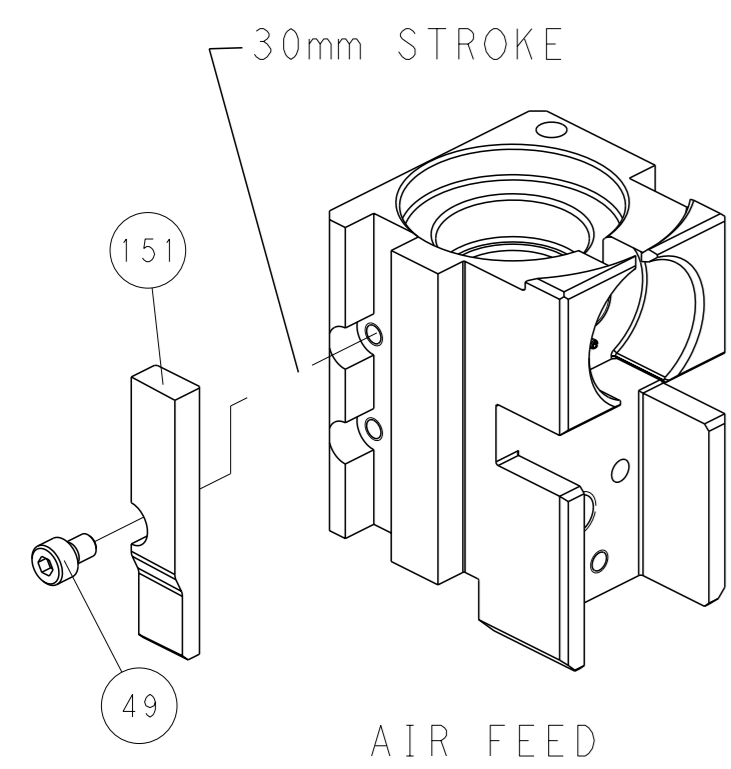

**PACIFIC VERSION**  
 Shown on sheets 3 of 4 & 4 of 4  
 (Atlantic version shown on sheets 1 of 4 & 2 of 4)

<small>THIS DRAWING IS A CONTROLLED DOCUMENT FROM TYCO ELECTRONICS CORPORATION. IT IS SUBJECT TO CHANGE AND THE CONTROLLER'S ENGINEERING ORGANIZATION SHOULD BE CONTACTED FOR THE LATEST REVISION.</small>		DWN Y.YIN 18OCT2011 CHK G.BAILEY 18OCT2011 APVD S.XI 18OCT2011	<b>STE</b> TE Connectivity Harrisburg, PA 17105-3608
DIMENSIONS: mm TOLERANCES UNLESS OTHERWISE SPECIFIED: 0 PLC ± 1 PLC ± 2 PLC ± 3 PLC ± 4 PLC ± ANGLES FINISH ±*		NAME Ocean Side Feed Applicator SIZE CAGE CODE DRAWING NO. A1 00779 ©=2151133 WEIGHT - SCALE 1:2 SHEET 4 OF 4 REV C	RESTRICTED TO
MATERIAL:		Customer Accessible Production Drawing	SHEETS 1 & 2 ARE NOT REQUIRED FOR PACIFIC VERSION